

T M 1 1 - 4 9 2 0 - 2 9 6 - 1 4 & P

TECHNICAL MANUAL

OPERATOR'S, ORGANIZATIONAL,
DIRECT SUPPORT AND GENERAL SUPPORT
MAINTENANCE MANUAL
(INCLUDING REPAIR PARTS
AND SPECIAL TOOLS LIST)

FOR

TRANSPONDER SET, TEST SET

AN/APM - 378

(NSN 4920-00-134-1533)

This copy is a reprint which includes current
pages from Change 1.

HEADQUARTERS, DEPARTMENT OF THE ARMY

SEPTEMBER 1980

WARNING

Do not make internal connections or adjustments alone. Always have another person available to help in case of an accident.

Dangerous voltage exists in this equipment. Injury may result if personnel fail to observe safety precautions. Use a common ground to connect the test set equipment under test and additional test equipments to the power source ground before applying power.

ELECTROMAGNETIC RADIATION HAZARDS EXIST AT THE WAVEGUIDE OUTPUT FROM THE POWER AMPLIFIER AND WITHIN THE DIRECTIONAL PATTERN OF THE ANTENNA! DO NOT STAND IN THE DIRECT PATH OF THE ANTENNA FOR WORK ON WAVEGUIDES WHILE POWER IS ON.

Adequate ventilation should be provided while using TRICHLOROTRIFLUOROETHANE. Prolonged breathing of vapor should be avoided. The solvent should not be used near heat or open flame; the products of decomposition are toxic and irritating. Since TRICHLOROTRIFLUOROETHANE dissolves natural oils, prolonged contact with skin should be avoided. When necessary, use gloves which the solvent cannot penetrate. If the solvent is taken internally, consult a physician immediately.

- 5 SAFETY STEPS TO FOLLOW IF SOMEONE IS THE VICTIM OF ELECTRICAL SHOCK.
 - 1 DO NOT TRY TO PULL OR GRAB THE INDIVIDUAL.
 - 2 IF POSSIBLE, TURN OFF THE ELECTRICAL POWER.
 - 3 IF YOU CANNOT TURN OFF THE ELECTRICAL POWER, PULL, PUSH, OR LIFT THE PERSON TO SAFETY USING A WOODEN POLE OR A ROPE OR SOME OTHER INSULATING MATERIAL.
 - 4 SEND FOR HELP AS SOON AS POSSIBLE.
 - 5 AFTER THE INJURED PERSON IS FREE OF CONTACT WITH THE SOURCE OF ELECTRICAL SHOCK, MOVE THE PERSON A SHORT DISTANCE AWAY AND IMMEDIATELY START ARTIFICIAL RESUSCITATION.

CHANGE

No. 1

HEADQUARTERS
DEPARTMENT OF THE ARMY
Washington DC, 16 November 1982

**Operator's, Organizational, Direct Support
And General Support Maintenance Manual
(Including Repair Parts And Special Tools List)
FOR
TRANSPONDER SET, TEST SET
AN/APM-378
(NSN 4920-00-134-1533)**

TM 11-4920-296-14&P, 30 September 1980 is changed as follows:

1. New or changed material is indicated by a vertical bar in the margin of the page.
2. Added or revised illustrations are indicated by a vertical bar in front of the figure caption.
3. Remove and insert pages as indicated below:

Remove	Insert
i, ii and iiii, ii and iii
0-1	0-1/(0-2 blank)
2-7(2-8 blank)	2-7 (2-8 blank)
2-15 and 2-16	2-15 through 2-16.1
3-27 and 3-28	3-27 and 3-28
3-31 (3-32 blank)	3-31 (3-32 blank)
4-1 and 4-2	4-1 and 4-2
4-7 and 4-8	4-7 and 4-8
4-9 through 4-12	4-9 through 4-12
4-17 through 4-20	4-17 through 4-20
4-23 (4-24 blank)..	4-23 (4-24 blank)
A-1 and A-2	A-1 and A-2

4. File this change sheet in front of the publication for reference purposes.

By Order of the Secretary of the Army:

Official:

ROBERT M. JOYCE
Major General, United States Army
The Adjutant General

E. C. MEYER
General United States Army
Chief of Staff

Distribution:

To be distributed in accordance with DA Form 12-36A, Organizational Maintenance Requirements for AN/APM- 123.

**OPERATOR'S, ORGANIZATIONAL, DIRECT SUPPORT AND
GENERAL SUPPORT MAINTENANCE MANUAL (INCLUDING
REPAIR PARTS AND SPECIAL TOOLS LIST)**

FOR

TRANSPONDER SET TEST SET

AN/APM378

NSN 4920-00-134-1533

REPORTING ERRORS AND RECOMMENDING IMPROVEMENTS

You can help improve this manual. If you find any mistakes or if you know of a way to improve the procedures, Please let us know. Mail your letter, DA Form 2028 (Recommended Changes to Publications and Blank Forms), or DA Form 2028-2 located in the back of this manual direct to Commander, US Army Communicatios Electronics Command and Fort Monmouth, ATTN: DRSEL-ME-MQ, Fort Monmouth, NJ 07703.

In either case, a reply will be furnished direct to you.

TABLE OF CONTENTS

SECTION		Page
0	INTRODUCTION	0-1
	Scope	0-1
	Index of Tecnical Publications.... .	0-1 ■
	Maintenance Forms, Records and Reports	0-1
	Reporting Equipment Improvement Recommendations (EIR)	0-1
	Adminisrative Storage	0-1
	Destruction of Army Electronics Materiel.	0-1
	Hand Receipt (-HR) Manual	0-1 ■
1	INTRODUCTION	1-1
	General	1-1
	Scope and Arrangement of Manual.	1-1
	Serialization	1-1
	Equipment Function	1-1
	Record of Applicable Technical Directives.	1-1
2	EQUIPMENT DESCRIPTION	2-1
	General	2-1
	Equipment Description and Capabilities.	2-1
	Equipment Supplied	2-1
	Equipment Required but Not Supplied.	2-1
	Principles Of Operation.	2-1
	Functionl Operation	2-1
	SIF Modes...	2-6
	Mode-3 and Mode-Test Emergency.	2-11
	Mode-4 Operation	2-11
	SIF Self-Test Mode.	2-12
	Mode-4 Self-Test	2-12
	RF Module A1	2-12
	Lamp Tast Mode	2-14
	Power Supply Circuits	2-14

SECTION	<i>Page</i>
Operation-----	2-15
Preventive Maintenance Checks and Services (PMCS)-----	2-17
Routine PMCS Services-----	2-17
3 INTERMEDIATE MAINTENANCE INSTRUCTIONS-----	3-1
General-----	3-1
Test Equipment Required-----	3-1
Checkout-----	3-1
Troubleshooting-----	3-1
RF Section, Troubleshooting-----	3-3
Bulk Items Consumable List-----	3-3
Disassembly-----	3-3
Removal of Digital Printed Circuit Cards-----	3-3
Removal of RF Module and Submodules-----	3-3
Removal of Chassis Assembly from Panel-----	3-3
Cleaning-----	3-3
Inspection-----	3-22
Repair-----	3-22
Limits-----	3-22
Assembly-----	3-22
Adjustment-----	3-22
Testing and Calibration-----	3-22
Wiring/Schematic Data-----	3-23
4 INTERMEDIATE TESTING PROCEDURES-----	4-1
General-----	4-1
Test Equipment Required-----	4-1
Intermediate Checkout Procedures-----	4-1
5 PRESERVATION, PACKAGING, AND PREPARATION FOR USE-----	5-1
General-----	6-1
Preservation Requirements-----	5-1
Preparation for Use-----	6-1
6 ILLUSTRATED PARTS BREAKDOWN-----	6-1
I. INTRODUCTION-----	6-1
Scope-----	6-1
Purpose and Use-----	6-1
Section I. Introduction-----	6-1
Section II. Group Assembly Parts List-----	6-1
General-----	6-1
Section III. Numerical Index-----	6-2
General-----	8-2
Figure and Index Number Column-----	6-2
Codes Column-----	6-2
Section IV. Reference Designation Index-----	6-2
Abbreviations-----	6-2
How to Use the Illustrated Parts Breakdown-----	6-3
Vendor Codes-----	6-3
II. GROUP ASSEMBLY PARTS LIST-----	6-7
III. NUMERICAL INDEX-----	6-23
IV. REFERENCE DESIGNATION INDEX-----	6-26
APPENDIX A. REFERENCE-----	A-1
B. COMPONENTS OF END ITEM LIST-----	B-1
C. ADDITIONAL AUTHORIZATION LIST-----	C-1
D. MAINTENANCE ALLOCATION-----	D-1
E. REPAIR PARTS LIST-----	E-1
F. EXPENDABLE SUPPLIES AND MATERIALS LIST-----	F-1

LIST OF ILLUSTRATIONS

<i>Number</i>	Title	<i>Page</i>
2-1	Transponder Set Test Set AN/APM-378-----	2-2
2-2	Test Set to Aircraft Transponder Relationships, Block Diagram-----	2-4
2-3	Transponder Set Test Set AN/APM-378, Functional Block Diagram-----	2-7
2-4	Timing Diagram, Encode Cycle (SIF Mode 3)-----	2-9

<i>Number</i>	<i>Title</i>	<i>Page</i>
2-5	Timing Diagram, Decode Cycle (SIF Reply Code 7777)-----	2-10
2-6	Transponder Set Test Set AN/APM-378, Controls, Indicators, and Con- nectors-----	2-15
2-1	Test Set, General Trouble Analysis Diagram (2 Sheets)-----	3-9
3-2	RF Section, Trouble Analysis Diagram-----	3-17
3-3	RF Module, Setup Diagram for T7 and T8 Frequency Tests-----	3-19
3-4	RF Module, Setup Diagram for T7 and T8 Power Tests-----	3-20
3-5	RF Module, T21 Setup Diagram-----	3-21
3-6	Power Supply Circuits, Schematic Diagram-----	3-27
3-7	Motherboard, Track Wiring, Schematic Diagram (2 Sheets)-----	3-28
3-8	RF Module A-1 PCB Track Wiring Diagram-----	3-30
3-9	Transponder Set, Test Set AN/APM-378, Front Panel Schematic Diagram-----	3-31
3-10	Special Jumper Cable for RF Circuits Maintenance (3 Sheets)-----	3-33
4-1	Power Supply Checks, Test Setup-----	4-5
4-2	Typical Test Setup Connections-----	4-6
4-3	Mode 4 Pretrigger Check, Test Setup-----	4-16
4-4	Mode 4 Typical Test Setup Connections-----	4-17
4-5	Special Mode 4 Calibration Connector-----	4-21
6-1	Transponder Set Test Set AN/APM-378-----	6-7
6-2	Test Set Cover-----	6-8
6-3	Transponder Set Test Set AN/APM-378, Rear View-----	6-10
6-4	Power Cable (PN 4035453-0501)-----	6-11
6-5	Power Cable Assembly (PN 4035549-0501)-----	6-12
6-6	Front Panel Assembly-----	6-14
6-7	Cable Assembly-----	6-16
6-8	Chassis Assembly-----	6-17
6-9	RF Module Assembly-----	6-20
6-10	Module Assemblies-----	6-22

LIST OF TABLES

2-1	Transponder Set Test Set AN/APM-378, Equipment Characteristics and Capabilities-----	2-3
2-2	Transponder Set Test Set AN/APM-378, Equipment Supplied-----	2-3
2-3	Transponder Set Test Set AN/APM-378, Equipment Required but Not Supplied-----	2-3
2-4	Transponder Set Test Set AN/APM-378, Characteristics-----	2-5
2-5	Transponder Set Test Set AN/APM-378, Operating Controls, Indicator, and Connectors-----	2-16
2-5.1	Transponder Set Test Set AN/APM-378 Operating Instructions-----	2-16.1
2-6	Preventive Maintenance Checks and Services-----	2-18
3-1	Transponder Set Test Set AN/APM-378, Maintenance Test Equipment Required-----	3-2
3-1.1	Transponder Set Test, Set AN/APM-378, Maintenance Test Equipment Required (Army)-----	3-2
3-2	Troubleshooting Analysis, Measurement Parameters-----	3-4
3-3	RF Section, Troubleshooting Analysis, Measurement Parameters-----	3-13
3-4	Inspection Suggestions-----	3-22
3-5	Transponder Set Test Set AN/APM-378, Wiring List-----	3-23
3-6	Cable Assembly W3, Wiring Data-----	3-25
3-7	Multipin Connectors J1 and J2, Pin Functions-----	3-26
3-8	RF Module A-1, Coaxial Cable Connections-----	3-26
4-1	Transponder Set Test Set AN/APM-378, Test Equipment Required-----	4-2
4-2	Radar Test Set AN/TPM-25A Controls-----	4-2
4-3	Transponder Set Test Set AN/APM-378, AN/TPM-25 Procedures-----	4-3
4-4	Transponder Set Test Set AN/APM-378, Adjustments-----	4-22

SECTION 0

INTRODUCTION

0-1. SCOPE

This manual describes Transponder Set Test Set AN/APM-378 and provides instructions for operation and maintenance.

0-2. INDEX OF TECHNICAL PUBLICATIONS

Refer to the latest issue of DA Pam 310-1 to determine whether there are new editions, changes, or additional publications pertaining to the equipment.

0-3. MAINTENANCE FORMS, RECORDS, AND REPORTS

a. Reports of Maintenance and Unsatisfactory Equipment. Department of the Army forms and procedures used for equipment maintenance will be those prescribed by TM 38-750, The Army Maintenance Management System.

b. Report of Packaging and Handling Deficiencies. Fill out and forward SF 364 (Report of Discrepancy (ROD)) as prescribed in AR 735-11-2/DLAR 4140.55/NAVMATINST 4355.73/AFR 400-54/MC0 4430.3E.

c. Discrepancy in Shipment Report (DISREP) (SF 361). Fill out and forward Discrepancy in Shipment Report (DISREP) (SF 361) as prescribed in AR 55-38/NAVSUP-INST 4610-33B/AFR 75-18MCO 4610.19C/DLAR 4500.15.

0-4. REPORTING EQUIPMENT IMPROVEMENT RECOMMENDATIONS (ERI)

If your Transponder Set Test Set AN/APM-378 needs improvement, let us know. Send us an EIR. You, the user, are the only one who can tell us what you don't like about

your equipment. Let us know why you don't like the design. Tell us why a procedure is hard to perform. Put it on an SF 368 (Quality Deficiency Report). Mail it to Commander, US Army Communications-Electronics Command and Fort Monmouth, ATTN: DRSEL-ME-MQ Fort Monmouth, NJ 07703. We'll send you a reply.

0-5. ADMINISTRATIVE STORAGE

Administrative storage of equipment issued to and used by Army activities will have preventive maintenance performed in accordance with the PCMS charts before storing. When removing the equipment from administrative storage the PCMS should be performed to assure operational readiness. Disassembly and repacking of equipment for shipment or limited storage are covered in paragraphs 5-4 through 5-4.

0-6. DESTRUCTION OF ARMY ELECTRONICS MATERIEL

Destruction of Army electronics materiel to prevent enemy use shall be in accordance with TM 750-244-2.

0-7. HAND RECEIPT (-HR) MANUALS

This manual has a companion document with a TM number followed by "-HR)) which stands for hand receipt). The TM 114920-296-10-HR consists of preprinted hand receipts (DA Form 2062) that list end item related equipment (i.e. COE1, BII and AAL) you must account for. As an aid to property accountability y, additional -HR manuals may be requisitioned from the US Army Adjutant General Publications, Baltimore, Maryland, in accordance with the procedures in Chapter 3. AR 310-2. and DA Pam 310-10-2.

SECTION 1 INTRODUCTION

1-1 GENERAL.

1-2. This manual contains intermediate level maintenance instructions with illustrated parts breakdown for the Transponder Set Test Set AN/APM-378 (also referred to herein as test set). This equipment is manufactured by The Bendix Corporation, Communications Division, Baltimore, Maryland 21204 under Contract N00019-73-C-0079.

1-3. SCOPE AND ARRANGEMENT OF MANUAL.

1-4. Data within this manual is divided into six section. Section 1 contains general information; Section 2 gives equipment description, theory and operating information. Section 3 gives the intermediate maintenance instructions for troubleshooting, disassembly, repair and reassembly, of the test set. Section 4 contains intermediate test procedures. Section 5 of the manual contains preservation, packaging, storage, and use information. Section 6 of the manual contains the illustrated parts breakdown (IPB) for the equipment.

1-5. SERIALIZATION.

1-6. The information contained in this manual is applicable to all Transponder Set Test Sets AN/APM-378 manufactured under Contract N00019-73-C-0079.

1-7. EQUIPMENT FUNCTION.

1-8. The AN/APM-378 test set is an accept/reject type tester, used at the flight-line to provide rapid indication of the operational status of AIMS Mark XII transponder equipments. The test set is capable of either direct- connected or radiated-path testing of transponders. In operation, the AN/APM-378 equipment generates interrogation pulses, and feeds (or radiates) them

to the aircraft transponder equipment. The resulting reply pulses from the transponder are then received and analyzed by the AN/APM-378; if correct replies were generated, the test set gives a visual ACCEPT indication.

1-9. Interrogation modes which can be checked by the test set include modes 1, 2, 3/A, C, test, and mode 4. In addition to checking for correct reply pulse sets generated by the aircraft transponder (with proper spacings), the AN/APM-378 also performs checks of the transponder transmitter frequency and power output, and emergency and I/P operability.

1-10. The AN/APM-378 test set is contained in a rugged combination case. Its circuits include self-check capability, to determine that the test set is fully operable, prior to its flight-line use. The test set is designed to check AIMS transponders, including the following: RT-859/APX-72; RT-859A/APX-72; RT-859B/APX-72 (Diversity); AN/APX-64; KY-532A; KY-533A; AN/APX-93; UPA-59; UPA-59A, UPA-60; RT-1156/APX-100, RT-1157/APX-100, and RT-1063/APX-101.

1-11. For detailed listing of the characteristics and capabilities of the test set, refer to Section 2.

1-12. RECORD OF APPLICABLE TECHNICAL DIRECTIVES.

1-13. A record of applicable Technical Directives is provided to identify the Technical Directive number(s), date of issue, title and the publication date of the manual change/revision/supplement which has incorporated new operation/maintenance information for the equipment on which the work described in the technical directive has been accomplished.

RECORD OF APPLICABLE TECHNICAL DIRECTIVES

TD No.	Date	Title	Change/Revision Supplement Date
Sec. 2789	March 1975	Improve EMI Capability (ECP-1R2)	30 Sept 1976

SECTION 2

EQUIPMENT DESCRIPTION

2-1. GENERAL.

2-2. This section contains detailed listings of the characteristics and capabilities of the Transponder Set Test Set AN/APM-378. Tables of equipment supplied, and equipment required but not supplied are part of this section. Principles of operation, functional operation, and operating information are also contained in this section.

2-3. EQUIPMENT DESCRIPTION AND CAPABILITIES.

2-4. The AN/APM-378 test set is a portable accept/reject tester, housed in a rugged combination case. A detachable cover of the case, in addition to protecting the controls and indicators of the test set, contains the accessory cables, and the antenna assembly. Power for the test set is obtained from 115 V ac or 28 V dc power sources at the flight-line locations where the test set is employed. Figure 2-1 shows the overall view of AN/APM-378 test set.

2-5. Table 2-1 lists the characteristics and capabilities of the AN/APM-378. The test set (completely solid state) employs strip-line rf circuits and integrated-circuits to provide maximum ruggedness and highest reliability. Built-in self-test circuits determine the test set operational readiness, prior to testing of transponders. Controls and indicators of the test set have been designed for simplicity of operation, and can be correctly manipulated even by operators wearing arctic gloves.

2-6. EQUIPMENT SUPPLIED.

2-7. Table 2-2 lists the equipment and components supplied as part of the Transponder Set Test Set AN/APM-378.

2-8. EQUIPMENT REQUIRED BUT NOT SUPPLIED.

2-9. Table 2-3 lists equipment/components which are required for maintenance or calibration of the Transponder Set Test Set AN/APM-378, but which are not supplied as part of the test set.

2-10. PRINCIPLES OF OPERATION.

2-11. Figure 2-2 shows the basic relationship of the test set to the transponder being checked. The test set transmits interrogation pulses to the aircraft transponder (via rf radiation from the antenna, or via direct-connected rf cables). If it is operating correctly, the transponder produces reply pulses and transmits them back to the test set. Internal circuits of the test set then check the received replies for proper pulse spacing/presence/absence, etc. For each check made by the test set, an ACCEPT or REJECT indication is given to indicate acceptable or unacceptable operation of the aircraft transponder.

2-12. When making Mode 4 tests, the test set generates a pretrigger, which is applied to the Interrogator Computer KIR-1A. The KIR-1A responds with a Mode 4 Interrogation Video Word, which modulates the test set transmitter. The resulting Mode 4 interrogation is sent to the transponder, which applies it to the associated IFF computer equipment. If the coding is correct the transponder replies to the test set. The resulting signals in the test set are then applied to the KIR-1A as Reply Video, which generates a TDV signal. This TDV signal, and a GTC pulse are fed from the KIR-1A to the test set; both signals must occur coincidentally in order to generate an ACCEPT indication in the test set.

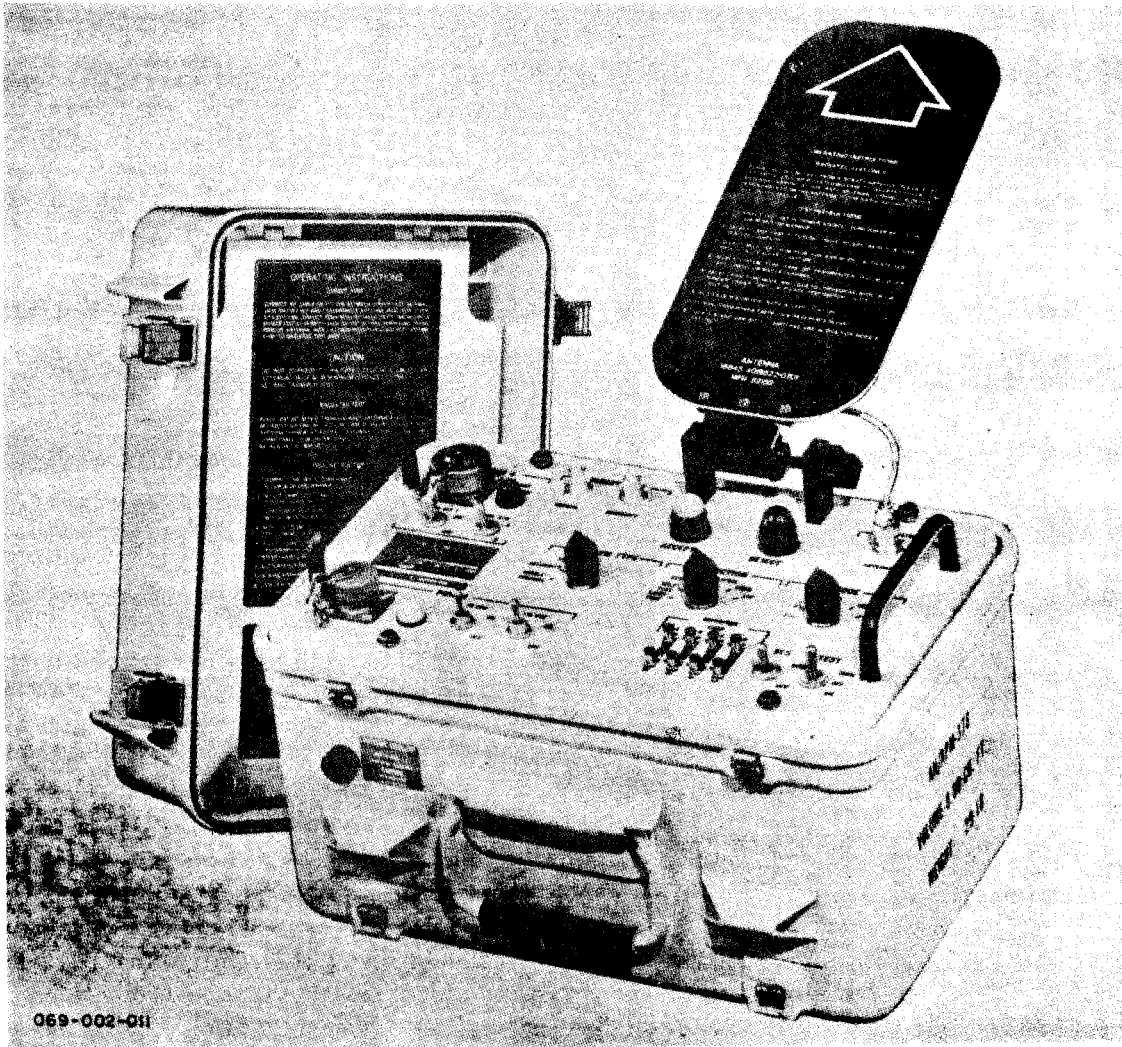

Figure 2-1. Transponder Set Test Set AN/APM-378

Table 2-1. Transponder Set Test Set AN/APM-378, Equipment Characteristics and Capabilities

Physical Characteristics:	
Overall Dimensions.	14.13 inches long 10.38 inches wide 12.0 inches high
Overall Volume.	0.8 cubic feet
Weight.	29 pounds
Input Power Requirements.	115 V ac, 60 or 400 Hz at 0.4 A 28 V dc at 1.0A
Environmental Limitations	-40 to +71 degrees C (operating), -62 to +85 degrees C (storage)
Test Set Functions	Lamp-Test, Self-Test, System, Frequency/Power, Emergency, and I/P
Transponder Modes Checked by Test Set . .	Mode 1, 2, 3/A, C, (with or without SPI puke), Test, 4 (with use of interrogator Computer KIR-1A)
Input Pulse Signals Required by Test Set . . (Mode 4 only)	Mode 4 Video Interrogation Word, SLS Pulse, GTC Pulse, and TDV Pulse
Output Pulse Signals Produced by Test Set . .	Mode 4 Pretrigger, and Reply Video

Table 2-2. Transponder Set Test Set AN/APM-378, Equipment Supplied

QTY	ITEM	NOMENCLATURE	PART NUMBER
1	Transponder Set Test Set	AN/APM-378	4035500
1	Panel and Chassis Assembly	-	4035452
1	Antenna Assembly	-	4035456
1	Cable, AC Power	W1	4035453
1	Cable, DC Power	W2	4035549
1	Special purpose Cable	W3	4035457
2	RF Cable (25 feet)	W4	4035454
1	RF Cable (6 inches)	W5	4035455
1	Resistive Load	AT1	2027369

Table 2-3, Transponder Set Test Set AN/APM-378, Equipment Required but Not Supplied

QTY	ITEM	NOMENCLATURE E
1	Special Jumper Cable	Figure 3-10
1	Mode 4 Calibration Connector	Figure 4-11

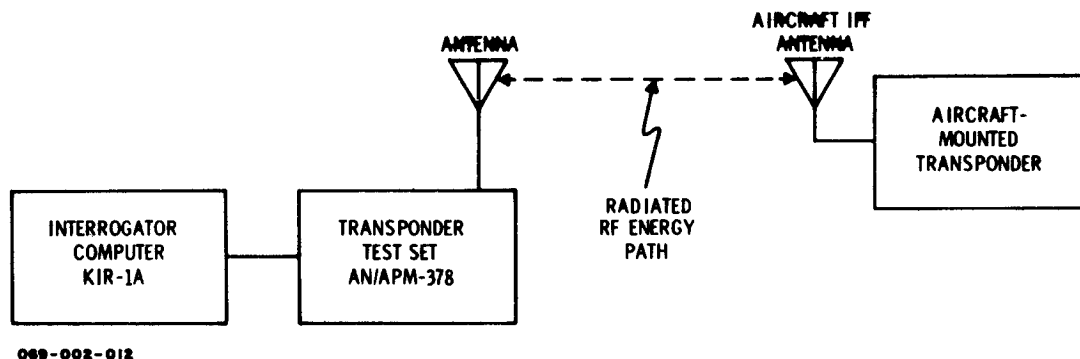

Figure 2-2. Test Set to Aircraft Transponder Relationships, Block Diagram

2-13. In the Mode 4 self-test, the KIR-1A may, or may not be connected to the test set. With the KIR-1A connected, signals are routed from the test set to the Interrogation Computer in a manner similar to actual Mode 4 system operation. If the KIR-1A is not connected during the Mode 4 self-test, the test set supplies signals which effectively test its own Mode 4 circuits.

2-14. The preceding discussion describes the general basic system-testing operation of the test set. The test set checks three types of transponders; namely, single-channel, diversity-type, and lobing systems. For all types of systems, any mode may be selected for test. In addition to MODE selection, the test set controls the FUNCTION to be tested. Functions include; system testing (basic); VP; emergency; lamp-testing; and frequency/power checks.

2-15. When the test set is first energized, the FUNCTION switch is placed in its SELF-TEST position. This exercises the test set circuits, and yields an ACCEPT indication (lamp lights) if all circuits are operating correctly. Once the self-test has established correct test set operation, system-testing operations can be accomplished, knowing that a REJECT indication (lamp lights) must be caused by incorrect operation of the transponder.

2-16. The test set SLS pulse control enables the operator to check the transponder for proper response in the presence or absence of the SLS pulse.

2-17. Table 2-4 lists the specific inputs/outputs of the test set and their pertinent characteristics.

2-18. FUNCTIONAL OPERATION.

2-19. Figure 2-3 shows the functional block diagram of the test set. This set consists of two major sections; the digital section (composed of four nonreparable solid-state modules) and the rf section (composed of rf module A1 and its three nonreparable rf-type subassemblies).

2-20. Circuit operation occurs in two basic cycles; encode, and decode. During each of these cycles, signals are timed (clocked) by internal clock signals, whose frequency varies according to the cycle of operation. Basic signal timing is derived from an internal 22-MHz oscillator, whose output is counted-down to the required CLOCK rate. During SIF interrogation modes (in the encode cycle), the CLOCK rate is 1 MHz; for Mode 4 interrogation the CLOCK rate is 555 kHz. During the decode cycle of operation, the CLOCK rate changes to 690 kHz for the SIF mode replies (or remains at the 555 kHz rate for the Mode 4 replies).

2-21. During the encode cycle, the digital circuits generate coded output pulse sets, whose timing and coding are determined by the front panel control settings. These digital signals are then fed to the rf module circuits, where they gate (modulate) rf oscillator stages to produce output interrogation rf pulses (at 1030 MHz). Timing of

Table 2-4. Transponder Set Test Set AN/APM-378, Characteristics

Transmitter Output	1030 ±0.2 MHz, -6 dBm ±1 dB	
Stability	±3 dB	
Duty Cycle	1%	
Receiver:		
Bandwidth	7.0 ±1 MHz (-3 dB points)	
Sensitivity	-6 dBm ±1 dB	
Sensitivity Stability	±3 dB	
Antenna:		
Beamwidth - Horizontal	400 to 80° (3 dB points)	
Beamwidth - Vertical	5° to +50° (amplitude variation less than 6 dB)	
Interrogation Rate	257 ±5 Hz	
Interrogation Pulses:		
<u>Mode</u>	<u>Pulse Width</u>	<u>Spacing</u>
1	0.7 - 0.9 μs	3 ± 0.2 μs
2	0.7 - 0.9 μs	5 ± 0.2 μs
3/A	0.7 - 0.9 μs	8 ± 0.2 μs
C	0.7 - 0.9 μs	21 ± 0.2 μs
Test	0.7 - 0.9 μs	6.5 ± 0.2 μs
4	0.7 - 0.9 μs	Mode 4 spacing
Reply Pulses - Analysis Capability:		
Pulse Spacing Variation	±0.15 μs - ACCEPT	
(from correct nominal)	±0.3 μs - REJECT	
Mode 3 SPI	(With or without F3 pulse.)	
Side Lobe Suppression	SLS control pulse alternates between 0 and 11 ±1.5 dB below level of interrogation pulses.	
Control Pulse Spacing	2 ± 0.15 μs from P1 pulse, for any mode.	
Mode	8 ± 1.5 μs after the first pulse.	
	ACCEPT indication for correct replies to > 80% or 40% (see paragraph 2-39) of interrogations.	
SIF and I/P:		
I/P	Mode C, with or without SIF pulse.	
I/P	Mode 1, 2, 3/A, Test. (SIF Modes).	
Emergency/Frequency/Power Checks:		
Frequency	1090 ± 3 MHz, ACCEPT	
	Less than 1086 or greater than 1094 MHz, REJECT	
Power	-6 dBm ± 1 dB, ACCEPT	
Self-Test	Checks test set circuits for all modes of operation.	

the output rf pulses is the same as that of the digital signals which control them. From the rf module output, the rf pulses are fed to the transponder under test (either via the antenna, or via direct-connect cables). Upon completion of the transmission of output rf pulses, the encode cycle ends, and the circuits switch to their decode cycle.

2-22. During the decode cycle, rf reply pulse sets are received from the transponder under test. In the rf module circuits, the reply pulses are detected (demodulated) to produce video-type pulses, whose coding and timing are that generated by the transponder under test. In the rf module, the frequency and relative power of the reply pulses are also checked. The video pulses from the detector circuits are then fed to the digital circuits, which now check the parameters of coded reply pulses. The parameters being checked include pulse timing, checks for extraneous or missing pulses, correct SLS action, etc. If all parameters of the reply are correct (for the specific mode and code used for interrogation), the digital circuits light an ACCEPT lamp on the front panel. Conversely, if any parameter is incorrect, the circuits light a REJECT lamp.

2-23. Actually, the ACCEPT or REJECT lamps are not lighted on the basis of a single testing cycle (encode and decode cycle). Basic testing cycles are repeated at the rate of 257 cycles per second. This repetitive cycling is required to determine if a transponder replies correctly to a specified percentage of interrogations. During testing, the digital circuits determine the percentage of correct replies (of the total number of test interrogations made), and light the REJECT lamp if the transponder fails to meet the specified percentage.

2-24. The rf module circuits also check the frequency and relative power of the reply pulses received from the transponder. If frequency and power are within specifications, a signal is fed to the digital circuits, to cause lighting of the ACCEPT lamp. If either the frequency or power of the reply pulses is incorrect, the REJECT lamp is lighted. During SYSTEM testing, the

frequency/power signal is fed to the digital circuits, which also examine the reply pulses for other parameters.

2-25. Other modes of the test set include lamp-testing and self-testing modes. In the lamp-test mode, signal levels are applied to the stages controlling the indicator lamps, to cause them to light; if any lamp fails to light during this check, it is possibly burned out, and maintenance actions are required. For the self-test mode operation, the digital circuits generate special interrogation pulses and apply them to the rf module circuits, where they produce output of interrogation pulses. The resulting rf output pulses are demodulated in the receiver stages, and fed to digital stages which check for known parameters of the special self-test signals. If all stages of the test set are operating correctly, they will cause an ACCEPT indication during the self-test mode.

2-26. The following discussions briefly describe signals and actions occurring in the test set circuits, for various modes of operation. For these discussions refer to figures 2-4 and 2-5 for timing diagrams of the various signals, and to the functional block diagram of figure 2-3. First, the digital circuit operations (by modes) are discussed, followed by discussions of the rf module, and the power supply circuits of the test set.

2-27. SIF MODES. For SIF mode testing, encode-cycle signals are clocked at 1-MHz rate (1-microsecond period), and decode-cycle actions are clocked at 690-kHz rate (1.45-microsecond period). When the TEST switch is placed at ON position during an SIF mode test, the following actions occur.

2-28. At the beginning of the encode cycle, a DATA pulse appears at U3-TP1, and is loaded into a register, by the next-occurring CLOCK pulse. This generates a To pulse (at U2-TP4), which initiates the P1 interrogation pulse. The DATA pulse is shifted through the register stages (at the CLOCK rate) and is tapped-out at the 2- μ s tap (U4-TP2) to initiate the P2 interrogation pulse. Farther down the register-stage chain, the DATA pulse is again tapped-out,

Figure 2-3. Transponder Set Test Set AN/APM-378, Functional Block Diagram. (Located in back of manual).

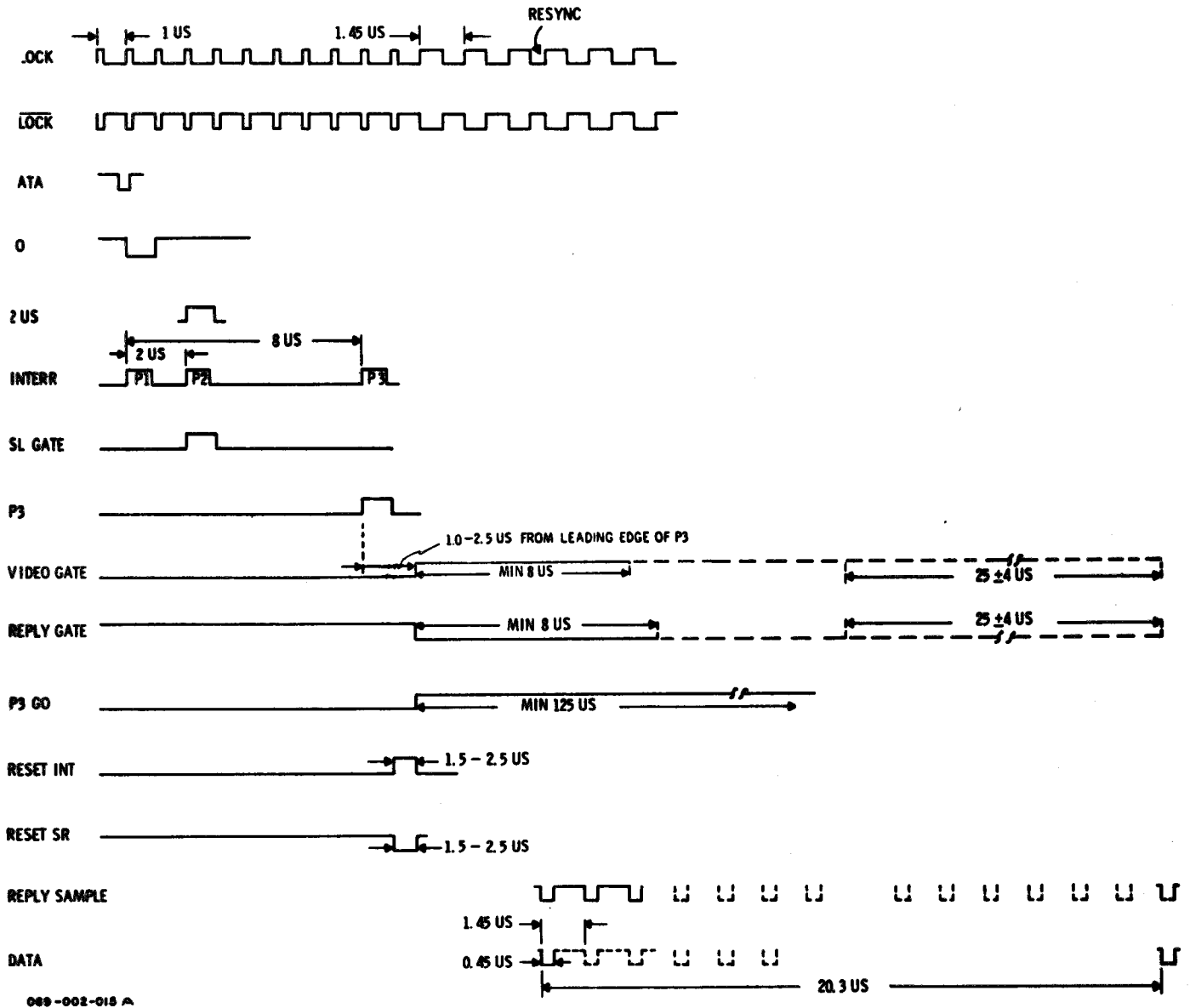

Figure 2-4. Timing Diagram, Encode Cycle (SIF Mode 3)

to initiate the P3 interrogation pulse; the specific register tap-out point for the P3 pulse (determined by the MODE selection switch) produces the specified spacing of the P1 and P3 pulses for the mode selected.

2-29. The three pulses (P1, P2, and P3) are regenerated into standard-width INTERR-ogation pulses (at U2-TP8) and are fed to the rf module circuits where they gate (modulate) the 1030-MHZ rf transmitter circuits. Additionally, the P2 pulse is applied from U4-TP1 to the SLS GATE

circuits of the rf module, to develop the side lobe function.

2-30. The P3 pulse so developed in the digital circuits performs several functions within those modules. It causes the RESET INT signal (U1-TP5) and the RESET SR signal (U1-TP10) to clear the register stages of all encode-cycle data. The trailing edge of the P3 pulse (at U3-TP6) causes changing of the CLOCK rate to 690 kHz for the following decode period. Also, the P3 pulse triggers a delayed (1.5 - 2.5

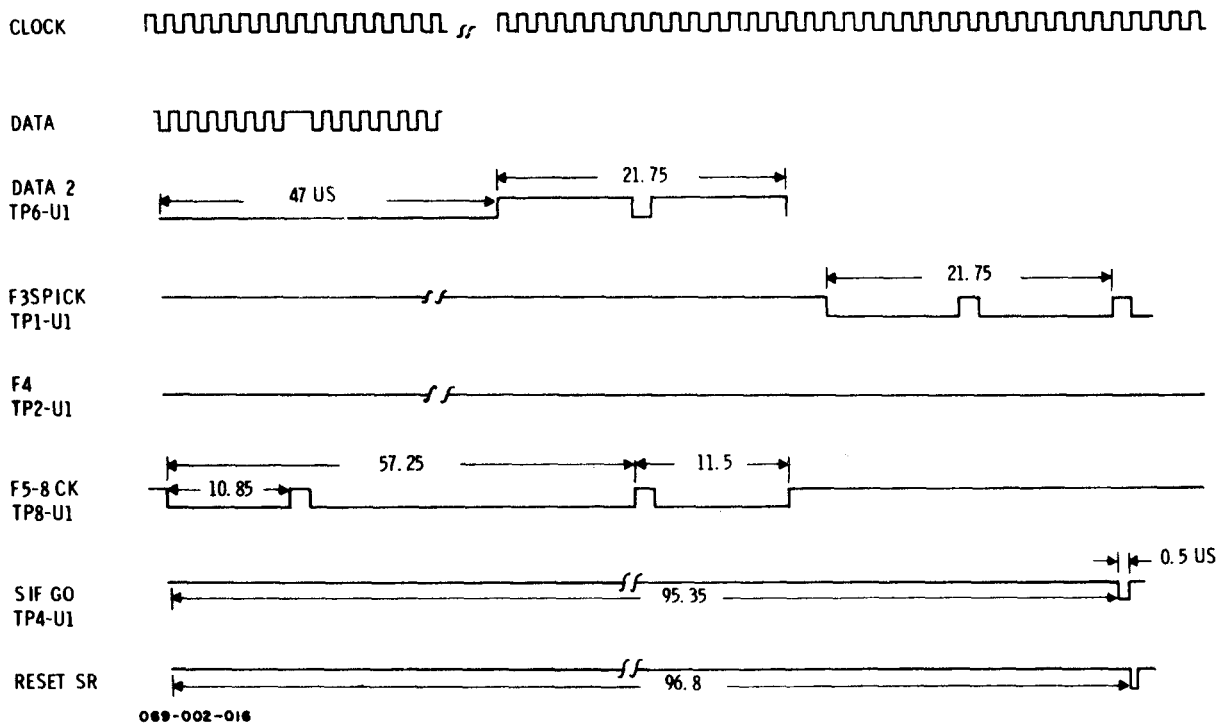

Figure 2-5. Timing Diagram, Decode Cycle (SIF Reply Code 7777)

microseconds) VIDEO GATE signal (U3-TP3). After the delay period, the VIDEO GATE from U3-TP3 is applied to the rf module and gates the local oscillator for 8.5 microseconds, activating the receive circuits. In addition to these previous actions, the P3 pulse triggers generation of a REPLY GATE (U3-TP4), which inhibits any interrogations during the decode cycle.

2-31. Now during the decode cycle, when reply pulses (at 1090 MHz) are received from the transponder under test, they are down-converted to 30 MHz, detected (demodulated) in the rf module circuits, and their frequency and power are checked. (Frequency must be 1090 ± 3 MHz, and power must be -6 ± 1 dBm.) Provided the reply pulses meet the frequency/power requirements, they are sent to the digital section as the REPLY SAMPLE (U3-TP10). At this time, the reply pulse width is normalized to form the DATA signals at U3-TP1, and the CLOCK is desynchronized with the DATA to insure correct loading of the DATA into shift-register stages. Receipt of reply pulses also causes "hold-open" of the VIDEO GATE (at U3-TP3) such that the local oscillator (and receive function) will be enabled for at least

25 microseconds after receipt of the last reply pulse.

2-32. The DATA (at U3-TP1) is clocked through shift-register stages of U2, and appears at U1-TP6 as the DATA-2 input to shift-registers of U1. When the DATA-2 bit corresponding to the F1 reply pulse appears at a specified tap on the last shift-register stage, a parity strobe is generated. This strobe enables a parity circuit to then check for absence or presence of the reply frame and coding pulses (as applicable). The parity circuit compares the reply pulses received against a reply code set by positioning of the CODE SELECT switches on the test set front panel; the received reply must match that set by the CODE switches, to produce an ACCEPT condition. Additionally, F3, F4, and F5-to-F8 parity comparisons are made for pulses following the F2 pulse. If all comparison conditions are met (at the parity strobe time), a SIF GO strobe is generated (U1-TP4) and sent to the evaluator board U4 circuits.

2-33. As the F1 pulse of the DATA-2 signal is shifted past the parity-strobe tap of U1, a RESET SR pulse (U1-TP10) is generated

to clear all register stages. Basically, this action ends the decode-cycle. PRF circuits within the U3 module will determine when the next encode-cycle (interrogation) is to begin, and will at that time change the CLOCK rate to 1 MHz and generate a P1 pulse on the DATA line (at U3-TP1), to start the next encode-cycle. Encode (Interrogation) and decode (reply) cycles and actions then repeat, in the manner described thus far for one encode/decode cycle. The PRF circuits of U3 control the rate of encode/decode repetition such that interrogation/reply-checking occurs at a rate of 257 cycles per second.

2-34. Each time a correct reply is obtained from the transponder under test, the resulting SIF GO strobe is fed to the evaluator U4 circuits, as mentioned. An integrator/comparator circuit of U4 measures the percentage of times that correct replies are received (for the number of times the transponder is interrogated), and causes the ACCEPT lamp to light. If the correct-reply rate is greater than 80 percent of the interrogation rate. The 80-percent correct-reply criteria applies for testing of single-channel and diversity transponders. When testing lobing-type transponders, a lower threshold voltage is applied to the U4 comparator circuit, to cause the ACCEPT indication to be indicated for correct-reply rates greater than 40 percent of the interrogation rate.

2-35. **MODE-3 AND MODE-TEST EMERGENCY.** Operation of the test set circuits for Mode-3 and Mode-Test Emergency is similar to that described for the SIF modes. However, for these M3 and MT Emergency operations, the code is always 7700. The proper comparison code states for the parity comparison are then generated by the A&B ENABLE UI-TP9) and the C&D) DISABLE code selector (which bypasses the front panel CODE SELECT switches). In Mode C, there is no emergency function. Also, in Mode C, the test set will give an ACCEPT indication, either with or without a SPI pulse.

2-36. **MODE-4 OPERATION.** For Mode-4 (M4) operation, the test set is used in conjunction with an Interrogator Computer KIR-1A. The KH3-1A is connected to the test set via the M4 cable supplied with the test set.

- - - - -
CAUTION
 - - - - -

Use only the cable provided; use of other cables may result in damage to the AN/APM-378.

Additionally, during M4 operation, the front panel FUNCTION switch is placed in the SYSTEM position, and the MODE switch is set for MODE 4. During M4 Operation, the CLOCK rate in the test set is 555 kHz (1.8-microsecond period). In the same manner as for the SIF modes discussed previously, the encode-cycle of operation begins with a counted-down CLOCK signal generating the To Pulses (U2-TP4). This action sends the M4 PRETRIGGER to the KIR-1A, which then returns the M4 VIDEO interrogation word. The M4 VIDEO pulses are shaped in U4 circuits, and are then sent to the U2 circuits (U2-TP10). From U2, the pulses are applied as Interrogation pulses (U2-TP8) to the rf module to modulate the 1030-MHz transmitter stages.

2-37. In response to the M4 PRETRIGGER, the KIR-1A equipment also applies an M4 GTC signal to the test set. This signal triggers an approximately 78-microsecond gate to yield a GTC GO signal (U3-TP9), which in turn provides a VIDEO GATE (U3-TP3) that enables a 3-pulse decoder in the U4 module.

2-38. As for SIG mode operation, the transmitter rf pulses during the encode-cycle cause the transponder under test (and its associated Interrogator Computer equipment) to generate reply pulses. These reply pulses are checked for correct power and frequency in the rf module circuits, and if correct, are detected and sent as the REPLY SAMPLE data to the digital section (U3-TP10). Upon receipt of the REPLY SAMPLE data, CLOCK is desynchronized and the data is loaded into shift-register stages. At this time, the 3-pulse decoder that was enabled in response to the GTC GO signal (U3-TP9) checks for coincidence of To (U2-TP4), the 1-microsecond tap signal (U2-TP2), and the 2-microsecond tap signal (U4-TP2). If correct coincidence occurs for this check, a pulse is applied to one input of an AND circuit of U4.

2-39. The REPLY SAMPLE data, after regeneration, is also applied to the KIR-1A Interrogator Computer as the M4 REPLY

VIDEO. If the reply is correct, the KIR-1A feeds a TDV signal to the test set, where it is applied to the second input of the U4 AND circuit (whose other input is the coincidence-check pulse). With both inputs receiving correct signals, the AND circuit then enables the evaluator U4 circuits to count the reply as a correct reply (in the same manner as it counts SIF GO pulses for SIF modes). Thus the U4 circuits will light an ACCEPT lamp if the correct-reply rate exceeds the specified 80, or 40 percent of interrogations (as determined by the type of transponder being tested).

2-40. SIF SELF-TEST MODE. For self-test operation, the FUNCTION switch is placed in the SELF TEST position, and the MODE switch is placed in any of its positions. In this operation, the counted-down CLOCK generates a DATA pulse (U3-TP1), which is loaded into the shift-register as the To pulse (U2-TP4) and results in an SIF P1 pulse (U3-TP5) and a VIDEO GATE (U3-TP3) to activate the receiver circuits video gating. Additionally, initiation of the To pulse causes a P1 interrogation pulse (U2-TP8), which is applied to the rf module as the 1030-MHz transmitter modulation.

2-41. Since the receiver circuits are gated-on by the VIDEO GATE while the P1 pulse is being transmitted, the transmitted P1 pulse is received, detected, and appears as a REPLY SAMPLE pulse (U3-TP10) to the digital circuits. This REPLY SAMPLE pulse desynchronizes the CLOCK, and appears as DATA (U3-TP1) to be loaded into the shift-register stages. When loaded, this DATA becomes the C1 pulse following the F1 pulse that was previously generated. The F1 and C1 pulses are now shifted through the register, and at the proper tap, an F2 pulse is generated. This F2 pulse is then sent to the rf module as a modulation pulse, and is then channeled back to the digital section as a REPLY SAMPLE (DATA) pulse in the same manner as was the C1 pulse. Once loaded into the register, the special 3-pulse code (F1, C1, and F2) is shifted through the register as a normal SIF reply.

2-42. For this special 3-pulse REPLY, the front panel CODE select switches are bypassed, and the parity-check circuits are preset to look for F1, C1, and F2. Therefore,

the REPLY SAMPLE (DATA) must match, in order to generate an SIG GO strobe (U1 - TP4) and eventually therefore, to produce the ACCEPT indication.

2-43. MODE-4 SELF-TEST. As for the SIF self-test mode, the counted-down CLOCK generates a DATA pulse (U3-TP1), which is loaded into the shift-register to initiate the To pulse. In Mode 4, this To pulse then initiates generation of a 2-pulse M4 interrogation (U2-TP10), which is applied to the rf module as transmitter modulation (U2-TP8). The last of these interrogation pulses is also sent to GTC ST (U3-TP8), and generates a GTC GO signal (U3-TP9) which enables the 3-pulse decoder of U3 for approximately 78 microseconds.

2-44. In this M4 self-test mode, the transmitted signal is coupled to the receiver circuits, where it is processed and then coupled to the digital circuits as the REPLY SAMPLE (U3-TP10). Thus, the two pulses received are loaded into the shift-register. Together with the initial pulse that was generated, these pulses now appear as the To pulse (U2-TP4), the 1-microsecond tap pulse (U2-TP2), and the 2-microsecond tap pulse (U4-TP2). These signals are now applied to the 3-pulse decoder circuit of U3 and are evaluated as if they were a normal Mode-4 reply.

2-45. If the Interrogator Computer KIR-1A is not connected to the test set, a TDV signal is not required to produce the ACCEPT indication, since the output of the 3-pulse decoder triggers the ACCEPT circuit through the normal evaluation path. If the KIR-1A equipment is connected, during M4 self-test mode, an M4 PRETRIGGER is sent to the KIR-1A from the test set. The REPLY SAMPLE is then sent to the KIR-1A and if the reply is correct, the KIR-1A returns a TDV signal. This is the correct, and required, ACCEPT condition for this mode of operation.

2-46. RF MODULE A1. The rf module A1 receives video-type signals from the digital section of the test set, and produces pulsed rf outputs in response to those inputs. The rf output pulses from the rf module constitute the actual interrogation pulses applied

to the transponder. During the reply interval, the rf signals from the transponder are fed first to the rf module circuits, which detect (demodulate) them and produce the corresponding video signals that are then processed in the digital circuits. Secondary functions of the rf module include checking the frequency and power of the rf reply pulses, steering output interrogation pulses during testing of diversity type transponders, and checking that reply pulses are received from the correct transponder output. Circuits of the rf module also control the relative amplitude of side-lobe pulses, with respect to other interrogation pulses.

2-47. The three subassemblies of the rf retie are: the local oscillator-transmitter module the rf microstrip module; and the if. video module. The local oscillator-transmitter retie contains two electrically-identical crystal-controlled oscillator stages, which are gated to produce the output interrogation pulses (transmitter) and the local oscillator (LO) signal for the receive circuits (local oscillator). Both oscillator circuits use crystals whose fundamental frequency is 1/6 that of their output frequency, and both produce outputs greater than +4 dBm. The transmitter oscillator, gated by the interrogation input from the digital circuits, produces output rf pulses at 1030 MHz. During receive (reply) times, the local oscillator is gated by the VIDEO GATE input from the digital section, to produce the required 1060-MHz LO signal to the receive mixer circuits. The rf outputs from both oscillators are coupled to the rf microstrip module circuits via coaxial cables.

2-48. The rf microstrip module serves to transfer signals between itself and the other assemblies of the rf module A1, and also for transferring signals to and from the transponder under test. During single-channel transponder testing, the coded rf interrogation pulses (from the local oscillator-transmitter module) are applied through the rf microstrip module to the RADIATED TEST ANTENNA connector. From that point, the interrogation pulses are radiated (via the antenna) to the transponder. Reply pulses received from the transponder are

then fed back into the rf microstrip module, which directs them to mixer circuits within the module. Simultaneously with reception of reply pulses, the local oscillator output occurs from the local al oscillator-transmitter module; this LO signal is directed through the rf microstrip module circuits to the LO input of its mixer. Resulting 30-MHz if. pulses from the mixer are then directed by the rf microstrip module circuits to the if. video module circuits.

2-49. During testing of diversity type transponders, the test set varies the amplitudes of the rf signals transmitted from the NORMAL and DIVERSITY jacks, so that the strongest signal is alternately transmitted from the NORMAL and then the DIVERSITY jack. The actual steering signals for this alternating strongest signal are fed to the rf microstrip module from the if. video module. If operating correctly, the transponder will feed its reply pulses back into the jack (NORMAL or DIVERSITY) that transmitted the strongest signal interrogation. The rf microstrip module processes the reply pulses in the same manner as for single-channel replies, and feeds the resulting 30-MHz if. pulses to the if. video module. By use of the steering signals, and detected rf sample signals from the rf microstrip module, the if. video module logic circuits confirm that each transponder reply is received via the correct jack (NORMAL or DIVERSITY). By alternately transmitting the strongest signal between the NORMAL and DIVERSITY jacks, the test set checks the transponder ability to reply from either of its diversity outputs, in correct accord with the strongest signal reception. If correct diversity reply action occurs, the if. video module feeds a signal to the digital circuits, which allows the ACCEPT indication (providing all other parameters of the reply signal are correct).

2-50. In addition to the mixer and steering circuits, the rf microstrip module contains attenuator circuits which control the transmit (interrogation) pulse amplitudes, receiver sensitivity, and side lobe pulse amplitude.

2-51. The if. video module accepts the 30-MHz if. pulses from the rf microstrip

module, and processes these signals. If the frequency and power of the reply pulses are correct, the REPLY SAMPLE output occurs from the if. video module and is fed to the digital circuits (U3-TP10). During diversity transponder testing, steering signals are applied to the logic circuits of the if. video module; if the if. pulses are not received on the line that transmitted the strongest-signal, the if. video module circuits inhibit any REPLY SAMPLE output. Thus, replies received from the wrong output of the transponder will cause a REJECT indication.

2-52. During side-lobe operation, an SLS pulse input (U4-TP1) to the if. video module circuits is processed to produce an output to the rf microstrip module, and causes attenuation of the side-lobe pulse of any interrogation pulse set (side-lobe pulse as transmitted is -11 ± 1.5 dB below the amplitude of the other interrogation pulses). If side-lobe operation is not in effect, the SLS pulse input is disabled, and all interrogation pulses are transmitted with the same amplitudes.

2-53. During diversity operation, circuits of the if. video module, in response to ALT CHAN GATE input from the digital section, provide the actual steering control signals to the rf microstrip module, to alternately direct strongest (6 dB difference) interrogations to first the NORMAL and then the DIVERSITY. Simultaneously, the steering signals are applied to the logic circuits of the if. video module, to enable them to determine if the replies are received from the correct diversity output.

2-54. Although not specifically mentioned during the previous discussions, the transmitter oscillator circuits and the receive LO circuits are not simultaneously gated-on. These oscillators are controlled by the INTERR and VIDEO GATE inputs to the rf module, respectively; the INTERR inputs occur during the encode cycle and the VIDEO GATE inputs occur during the decode cycle. During self-test mode however, a VIDEO GATE input occurs to enable the receiver circuits of the rf module simultaneously with INTERR inputs to its transmitter circuits. This then allows each

output rf pulse during the self-test mode to be fed directly through the receiver circuits, to develop a REPLY SAMPLE pulse (one for each interrogation pulse, in that mode).

2-55. LAMP TEST MODE. To insure that all "result indicator" lamps of the test set are operative, the FUNCTION switch is placed in the LAMP TEST position. This action applies an input to the evaluator U4 stages controlling the ACCEPT and REJECT lamps, to cause both lamps to light simultaneously at this time. The front panel switch also supplies a ground path to the CODE ZEROIZE lamp to make it light.

2-56. POWER SUPPLY CIRCUITS. The test set can be operated from either ac or dc power sources, by means of the two types of power cables, and its two POWER switches. AC power must be in the range of 103.5 to 126.5 V ac, at frequencies of 50 to 70, or 380 to 420 Hz. DC power for the test set must be 25.0 to 31.0 V dc. Figure 3-6 shows the schematic diagram of the power supply circuits of the set. For ac power operation, the input voltage is applied to a step-down transformer/bridge-rectifier/filter circuit as shown. The output dc voltage is then applied to two integrated-circuit voltage regulator stages; these same stages receive the dc input power during dc operation.

2-57. The integrated circuit voltage regulator stages produce outputs of +12 V dc (at 330 mA, 0.1 percent regulation) and +5 V dc (at 600 mA, 0.1 percent regulation) that are applied to the solid-state circuits of the test set, and to the indicator lamps as shown. The regulator stages contain internal current-limiting, thermal-shutdown, and safe-area compensation capabilities.

2-58. The dropping-resistor in series with the +5 V dc regulator minimizes the differential voltage across the regulator stage. A series-dropping resistor is connected in the dc power input line, to drop that voltage to the same range as the dc output produced by the rectifier/filter circuits (during ac power operation).

2-59. OPERATION.

2-60. Figure 2-6 shows the operating controls and indicators of the test set.

Table 2-5 lists the controls and their functions. Operating instructions are in table 2-5.1 and on the lid of the accessory compartment in the equipment cover. Operation of the test set consists generally of the following steps; (C1) connecting/locating the test set for either the direct-connection or radiated-path method of test; (2) applying power to the test set; (3) lamp-testing and self-testing of the test set; (4) selection of the specific type of system (single-channel, etc) to be tested; (5) selection of the transponder mode and code; and (6) observation of the ACCEPT and REJECT Lamps.

2-61. Controls and lamps other than those associated with the basic testing operation, control operation as injecting SLS

pulses into the test interrogations, and checks/alarms associated with the Interrogator Computer KIR-1A (when it is being used for Mode 4 checks).

CAUTION

- Never directly connect the output of a transponder equipment to the RADIATED TEST ANTENNA connector of the test set. If for some operation, it is required to feed the transponder output into the RADIATED TEST ANTENNA connector, always insert an attenuator (at least 50 dB) in series between the transponder and the test set.
- Use only the cable supplied for M-4 connections.

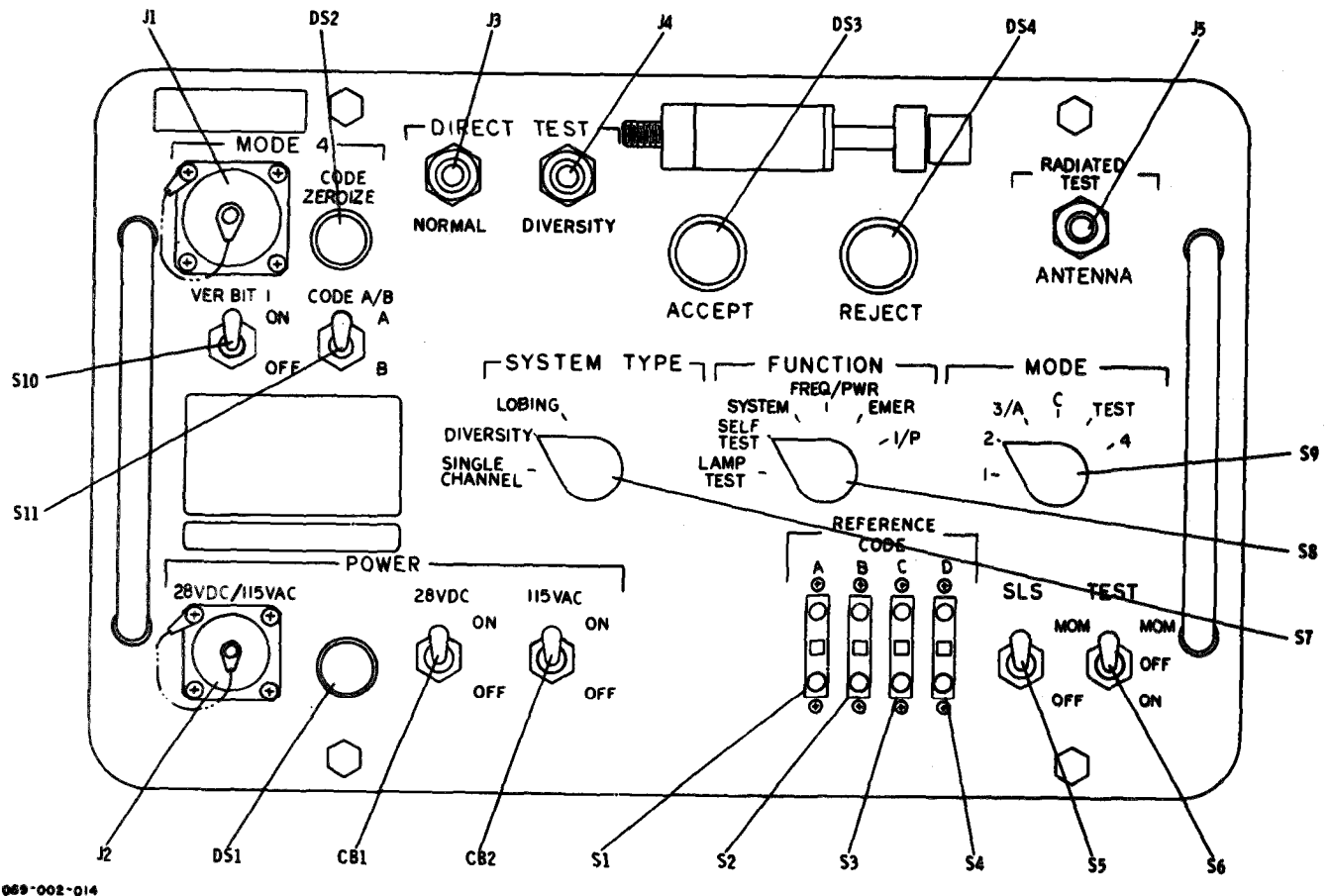

Figure 2-6. Transponder Set Test Set AN/APM-378, Controls, Indicators, and Connectors

Table 2-5. Transponder Set Test Set AN/APM-378,
Operating Controls, Indicators, and Connectors

CONTROL , INDICATOR, OR CONNECTOR	REF DES	FUNCTION
MODE 4 connector	J1	Connects Interrogator Computer KIR-1A to AN/APM-378 test set.
CODE ZEROIZE lamp (red)	DS2	Indicates alarm from KIR-1A.
VER BIT 1 ON/OFF switch	DS10	Selects verify 1 operation of KIR-1A.
CODE A/B switch	S11	Selects Code A or B operation for KIT-1A.
DIRECT TEST connectors NORMAL DIVERSITY	J3 } J4 }	Test set connections used for direct connection to transponder, either normal (single-channel) or diversity.
ACCEPT lamp	DS3	Indicates results of test are acceptable - transponder OK.
REJECT lamp	DS4	Indicates results of test are not acceptable - transponder faulty.
RADIATED TEST ANTENNA connector	J5	Connects AN/APM-378 output/input to test set antenna.
POWER-28 VDC/115 VAC connector	J2	Connects input ac or dc power to test set.
Lamp	DS1	Indicates power ON.
28 VDC switch (ON/OFF) 115 VAC switch (ON/OFF)	CB1 } CB2 }	Control application of 115 V ac or 28 V dc, whichever is being used.
SYSTEM TYPE switch	S7	Selects type of system (single-channel, diversity, or lobing mode) to be tested.
FUNCTION switch	S8	Selects test set mode - LAMP TEST, SELF-TEST, SYSTEM, FREQ/PWR, EMER, or I/P.
MODE switch	S9	Selects transponder mode (1, 2, 3/A, C, TEST, or 4) to be tested.
REFERENCE CODE switches A, B, C, D	S1 thru S4	Select transponder codes in use.
SLS-MOM/OFF switch	S5	Injects SLS pulses into interrogations, when in MOM position.
TEST -MOM/OFF/ON switch	S6	Initiates testing (interrogation/reply checks) when in MOM or ON position.

Table 2-5.1. Transponder Set Test Set AN/APM-378,
Operating Instructions

DIRECT TEST

Connect RF cable (25 feet) (W4) between DIRECT TEST (NORMAL) jack on test set and transponder antenna jack. For diversity system, connect remaining RF cable (25 feet) (W4) between DIRECT TEST (DIVERSITY) jack on test set and remaining transponder antenna jack. Attach resistive load AT1 (2027369) to RADIATED TEST jack.

CAUTION

Do not connect transponder output to RADIATED TEST unless an attenuator of 50 DB minimum is placed between test set and transponder.

RADIATED TEST

Place test set 50 feet from aircraft antenna. Elevate test set above ground by latching case to inverted cover. Aim antenna (arrow) at aircraft antenna. Connect 6 inch antenna cable (W5) from the antenna to the RADIATED TEST ANTENNA jack on the test set.

TEST INSTRUCTIONS

1. Connect test set to power source. Turn POWER switch ON. Allow 30 seconds warmup.
2. Select LAMP TEST FUNCTION. Note ACCEPT, REJECT, and CODE ZEROIZE lights on.
3. Select SELF TEST FUNCTION for any mode. Activate TEST switch, note ACCEPT light on.
4. Select SYSTEM TYPE (type of transponder system under test) LOBING or SINGLE CHANNEL.
5. Select FUNCTION mode and CODE to correspond with transponder under test. Activate TEST switch. Note ACCEPT light on.
6. Activate SLS switch. Note ACCEPT light on.
7. During FREQ/POWER tests CODE reference is inactive.
8. CODE A/B and VERT BIT 1 switches are active for MODE 4 test only.

2-62. PREVENTIVE MAINTENANCE CHECKS AND SERVICES (PMCS)

2-63. The PMCS requirements for the Transponder Set Test Set AN/APM-378 are listed in table 2-6. There are certain tests that can be done routinely, before (B) and during (D) operation. Other PMCS are done on a weekly basis or when dictated by special circumstances as listed in table 2-6.

2-64. Before you operate, Always keep in mind the CAUTIONS and WARNINGS. Perform your before (B) PMCS.

2-65. While you operate. Always keep in mind the CAUTIONS and WARNINGS. Perform your during (D) PMCS.

2-66. After you operate. Be sure to perform your after (A) PMCS.

2-67. If your equipment fails to operate. Troubleshoot with proper equipment. Report any deficiencies using the proper forms, see TM 38-750.

2-68. ROUTINE PMCS SERVICES

2-69. Routine services are a collection of checks and observations performed by the operator at all times. Routine services are not listed in the preventive maintenance checks and services (table 2-6), in order to separate the nonoperational from the operational services.

1. Clearing.
2. Dusting.
3. Washing.
4. Check for cut or frayed cables.
5. Check for dented, bent or broken components.
6. Check to see that items not in use are properly stowed.
7. Check for rusting.
8. Check controls for smooth operation.
9. Cover unused receptacles.
10. Check for loose nuts, bolts, and connectors.
11. Check to see that all nameplates are clean and legible.
12. Check for completeness of equipment.

Table 2-6. Preventive Maintenance Checks and Services

B = Before Operation M = Monthly S = Special Situation*

ITEM	INTERVAL			PROCEDURE	EQUIPMENT IS NOT READY/ AVAILABLE IF COLUMN
	B	s	M		
1	•	•		Perform an operability check IAW the operating instructions in paras. 2-59 through 2-61 and operating instructions on the lid of the accessory cable compartment in the cover of the equipment.	The operability check results in a condition whereby the equipment will not be able to complete its intended mission because of equipment malfunction or lack of required equipment. URGENT MWO has not been applied.
2			•	Check that all pertinent publications required for operation and maintenance are current and serviceable.	
3		•	•	Check DA Pam 310-7 to determine whether new applicable MWO's must be applied immediately, all MWO's must be scheduled.	

* Perform at initial set-up and whenever Test Set is relocated or when integrity of operation is in doubt.

SECTION 3

INTERMEDIATE MAINTENANCE INSTRUCTIONS

3-1. GENERAL.

3-2. This section contains the intermediate maintenance information for the Transponder Set Test Set AN/APM-378. Information is included for checkout and troubleshooting, to isolate any malfunction to a faulty replaceable module or assembly. Disassembly, cleaning, inspection, and reassembly data are also given in this section.

3-3. TEST EQUIPMENT REQUIRED.

3-4. Table 3-1 lists the test equipment required for troubleshooting of the test set, at the intermediate maintenance level.

3-5. CHECKOUT.

3-6. Checkout of the test set is accomplished by means of the self-test features built into the unit. This type checkout is normally performed during each usage of the test set, to determine that it is operating correctly before actually using it to check transponders.

3-7. Because of the modular construction, and high-reliability circuits used in the test set, most faults will be analyzed to a replaceable module. Repair will then consist of replacement of that faulty module, and the quick checkout (via self-test) used to confirm that the module replacement has cleared the fault. Recalibration of the test set should be made following any repair, and at periodic intervals of approximately 6 months of use.

3-8. If satisfactory results are obtained from the performance of the calibration procedures, then the AN/APM-378 test set may be considered to be fully operational.

3-9. TROUBLESHOOTING.

3-10. Trouble analysis within the test set is accomplished by use of the trouble analysis flow diagrams of figures 3-1 and 3-2, and the procedures of tables 3-2 and 3-3. These procedures perform measurements in a logical sequence, and enable decisions at each point as to which replaceable module might be causing a faulty signal/measurement. In the trouble analysis diagrams, the diamond-shaped symbols indicate test steps, the rectangular symbols indicate equipment actions taken, and circles represent decision points.

3-11. Use of the trouble analysis diagram is as follows, Connect and energize the test set, and perform test step T1. Use test equipments designated for checkout with associated troubleshooting analysis table to determine the parameters for that test. If the measurement/indication is correct, follow the "good" (G) path from the diamond. If the indication or measurement is incorrect, follow the "not-good" (NG) path from the diamond. The G and NG paths will lead you to the next logical action/test to be made, or to a circle symbol. Within each circle, the probable module causing the fault will be stated; when the trouble analysis path has lead to a circle replace the module indicated. Following replacement of the indicated module, recheck the circuits by by performing the checkout procedures, or by performing the prior tests (of the trouble analysis diagram) which originally lead to that replacement.

3-12. The trouble analysis flow diagrams analyze troubles to the replaceable modules of the test set. The majority of malfunctions of the equipment will be analysed to such modules. However, it is possible for a trouble to occur within the power supply circuits, or with individual controls or

Table 3-1. Transponder Set Test Set AN/APM-378,
Maintenance Test Equipment Required

QTY	NAME	MIL TYPE No. /MFR & MODEL NO.
1	Attenuator, Fixed Coaxial 6 dB	Weinschel 2-6
1	Digital Multimeter	Fluke, Model 8800A/AA
1	Electronic Counter	Hewlett-Packard, Model 5245L
1	Oscilloscope, Dual Trace	Tektronix 475-4
1	Power Meter	General Microwave Corp. , Model 4017C/1
1	Transfer Oscillator	Hewlett-Packard, Model 5257A

Table 3-1.1. Transponder Set Test Set AN/APM4-378
Maintenance Test Equipment Required (Army)

QTY	NAME	MILITARY TYPE NUMER
1	Attenuator. Fixed 6dB	Weinschel 2-6
1	Digital Voltmeter	AN/GSM-64B
1	Electronic Counter	TD-1225(V)I/U
1	Oscilloscope	AN/USM-281A
1	Power Meter	AN/USM-161
1	Circulator	M3B-1030 (96341)
1	Pulse Generator	AN/UPM-15A

wiring of the test set. Therefore, when the trouble analysis diagram so indicates that the probable cause of the faulty indication is in wiring or power supply, check those circuits by use of the schematic and wiring diagrams, using normal voltage/resistance measurement techniques.

3-13. The flow diagrams of figure 3-1 and the procedures of table 3-2 refer primarily to digital problems of the U1, U2, U3 and U4 plug-in modules. The test points in figure 3-1, which are preceded by a 'U' number, refer to digital boards and are color coded. The other TP numbers are power supply test points, located on

chassis next to power transformer. Reference is also made to E-terminals located on the motherboard. All E-terminals are exposed adjacent to the base of the plug-in board housing.

3-14. The flow diagrams of figure 3-2 and the procedures of table 3-3 refer to video and rf problems. Tests are made on the underside of the rf housing by using an extender cable (extender cable is not supplied; must be fabricated). See the cable fabrication drawings of figure 3-10. Refer to figure 3-8 for the location of test points as indicated by the flow diagram of figure 3-2.

3-15. **RF SECTION, TROUBLESHOOTING.** If problems are detected from the general trouble analysis tests (figure 3-1 and table 3-2) which indicate faults within the rf module A1 or its subassemblies, proceed as follows:

1. Turn off power and remove the retaining screws from the rf module. Lift the module from its chassis connector, leaving the three rf cables attached to their jacks at the side of the module. Rotate the rf module to permit access to its printed circuit board assembly. Make a detailed inspection of the connections from the three rf modules to the printed wiring board assembly. If any are broken, repair and reinstall the A1 module. If this does not correct the test set malfunction, remove and reconnect the module to its chassis connector via an extender cable assembly.

2. Reapply power to the test set and perform the tests of table 3-3 and figure 3-2. Refer to the rf module A1 PCB track wiring diagram (figure 3-8) for identification of test points and locations.

3-16. When performing the trouble analysis tests for the rf module A1, use standard practices of connection (shortest possible leads, etc.). Some disconnection of leads may be necessary during those tests; care should be taken to prevent damage to components or PCB tracks. Always remove power to the test set prior to unsoldering/soldering connections. For continuity checks, insure that power to the test set is off. When the trouble analysis tests for the rf module A1 have been completed, check that all connections have been reconnected (if they were disconnected).

3-17. BULK ITEMS CONSUMABLE LIST.

3-18. The only items that are consumable bulk items are solder and rags used in unsoldering and soldering of leads to components to make parameter measurements of table 3-3.

3-19. DISASSEMBLY.

3-20. The test set is conventionally constructed, and can be disassembled into its component modules, chassis, and panel using normal maintenance tools. Separation of front panel from the case is accomplished by unfastening the four screws at the front panel, and pulling the front-panel/chassis assembly out of the case. Since all connections to the test set circuits are made

via front-panel connectors, no internal wires need to be disconnected during this operation.

3-21. Whenever disassembling the test set or its components, refer to the illustrations of Section 6 (IPB), for location of mounting screws, and placement of the components. Normal soldering and maintenance techniques are employed for disassembly of the equipment. During replacement of any part, tag all wires removed, and check that they are reinstalled to their correct points. Dress leads as nearly as possible to their original positions, when replacing parts.

3-22. **REMOVAL OF DIGITAL PRINTED CIRCUIT CARDS.** The four replaceable printed circuit-card modules of the test set are mounted in the card cage behind the front-panel assembly. Removal of any of these cards consists of unfastening the card-retaining bar and pulling the specific card from its mounting connector (by operating the card insert/extraction levers).

3-23. **REMOVAL OF RF MODULE AND SUBMODULES.** To remove the rf module from its normal mounting position on the chassis, first disconnect the rf cables connected to its jacks. Then loosen the two captivated hold-down screws, and lift the module out of its chassis connector. Access to the submodules of the rf module requires removal of its protective cover. Individual submodules can then be removed by disconnection of their wires, and removal of their mounting screws. Exercise care when removing or replacing submodules, to avoid damaging connector contacts, or other components in the process of replacing one submodule.

3-24. **REMOVAL OF CHASSIS ASSEMBLY FROM FRONT PANEL ASSEMBLY.** For access to the front-panel controls, and to the power supply components of the test set, it is necessary to separate the front panel and the chassis assemblies. This is accomplished by removing the screws holding the chassis to the rear of the front-panel assembly. Normal unsoldering techniques are used to disconnect wires from any part being replaced.

3-25. CLEANING.

3-26. No special cleaning procedures are required for the test set.

Table 3-2. Troubleshooting Analysis, Measurement Parameters

TEST	PULSE	UNIT OF MEAS	MEASURED VALUE		TEST EQUIPMENT	CONTROL SETTINGS	REMARKS
			MIN	MAX			
					NOTE All pulses are TTL level Maximum LOW level = 0,3 V Minimum HI level = 2,4 V		
T1	-	V dc	11,4	12,6	Digital Multimeter	+dc volts	
T2	-	V dc	4,75	5,25	Digital Multimeter	+dc volts	
T3	-	V dc			Oscilloscope	2 μ s/cm INT POS TRIG	Check minimum and maximum TTL voltage levels.
	-	MHz	0,84880	1,00310	Electronic Counter	FREQUENCY	Connect test point to counter (use short cable).
T4	-	V dc	0,0	0,8	Oscilloscope	N/A	
T5	A	μ s	0,2	2,5	Oscilloscope	0,5 μ s/cm INT NEG TRIG	
T6	A	ms	7,6	8,0	Oscilloscope	1 ms/cm INT POS TRIG	
T7	A	μ s	0,9	2,6	Oscilloscope	1 μ s/cm INT NEG TRIG	Look at first pulse only.
T8	-	μ s	0,04	0,12	Oscilloscope	0,1 μ s/cm INT NEG TRIG	A HI level or narrow strobe is acceptable in this test.
T9	-	V dc	2,4	5,25	Oscilloscope	N/A	Only check for quiescent HI level in this test.
T10	A	μ s	0,9	-	Oscilloscope	0,5 μ s/cm EXT NEG TRIG	Use U2TP4 (To) as trigger. Do not check for maximum pulse width.
					NOTE EXT NEG TRIG using (To) U2TP4 for all tests follow- ing T10 unless otherwise specified.		

Table 3-2. Troubleshooting Analysis, Measurement Parameters (Cont)

TEST	PULSE	UNIT OF MEAS	MEASURED VALUE		TEST EQUIPMENT	CONTROL SETTINGS	REMARKS
			MIN	MAX			
T11	A	μs	0.9	2.5	Oscilloscope	1 $\mu s/cm$	Look at first pulse only.
T12	A	μs	0.6	1.0	Oscilloscope	2 $\mu s/cm$	1st pulse width
	B	μs	12.9	15.5	Oscilloscope	2 $\mu s/cm$	1st pulse leading-edge to 2nd pulse leading-edge.
	C	μs	1.9	2.8	Oscilloscope	2 $\mu s/cm$	2nd pulse width
T13	A	μs	0.6	1.0	Oscilloscope	0.2 $\mu s/cm$	1st pulse check only
T14	-	μs	21.0	-	Oscilloscope	5 $\mu s/cm$	Do not check for maximum pulse width.
T15	A	μs	0.3	1.3	Oscilloscope	1 $\mu s/cm$	1st pulse check only
T16	-	V dc	2.4	5.25	Oscilloscope	N/A	Check for HI level. Hold probe to 'E' terminal or insert in test point indicated.
T17	A	μs	-	-	Oscilloscope		Change mode selector on front panel as specified in test and check each delay period 'A'. Delay times are referenced to 'To' trigger.
M1	A	μs	5.0	7.0		1 $\mu s/cm$	
M2	A	μs	7.0	9.0	Oscilloscope	1 $\mu s/cm$	
M3/A	A	μs	10.0	12.0	Oscilloscope	2 $\mu s/cm$	
MC	A	μs	7.3	9.0	Oscilloscope	2 $\mu s/cm$	
MT	A	μs	22.0	27.2	Oscilloscope	5 $\mu s/cm$	
	B	ms	0.021	4.0	Oscilloscope	0.5 ms/cm	Same pulse width for all modes.
T18	A	μs	-	-	Oscilloscope	-	Change mode selector on front panel as specified in test and check each delay period 'A'. Delay times are referenced to 'To' trigger.
M1	-	μs	2.9	4.0	Oscilloscope	1 $\mu s/cm$	

Table 3-2. Troubleshooting Analysis, Measurement Parameters (Cont)

TEST	PULSE	UNIT OF MEAS	MEASURED VALUE		TEST EQUIPMENT	CONTROL SETTINGS	REMARKS
			MIN	MAX			
T18 (Cont)							
M2	A	μs	5.0	6.5	Oscilloscope	1 $\mu\text{s}/\text{cm}$	
M3/A	A	μs	7.8	10.0	Oscilloscope	1 $\mu\text{s}/\text{cm}$	
MT	A	μs	6.4	8.0	Oscilloscope	1 $\mu\text{s}/\text{cm}$	
	B	μs	0.45	0.6	Oscilloscope	2 $\mu\text{s}/\text{cm}$	Pulse B is split into two pulses of equal width in Mode T. 1st pulse leading-edge to last pulse leading-edge. Same for all modes except MC (absent D pulse).
	C	μs	12.9	16.0	Oscilloscope	5 $\mu\text{s}/\text{cm}$	
	D	μs	0.45	0.6	Oscilloscope	5 $\mu\text{s}/\text{cm}$	
MC	A	μs	20.0	25.0	Oscilloscope	5 $\mu\text{s}/\text{cm}$	
M1, M2, M3/A, MC	B	μs	1.9	2.8	Oscilloscope	5 $\mu\text{s}/\text{cm}$	Same pulse width for all modes except MT.
M1, M2, M3/A	D	μs	0.9	1.3	Oscilloscope	5 $\mu\text{s}/\text{cm}$	Same pulse width for all modes except Mode C where D pulse is absent, and Mode Test.
T19	-	-			Oscilloscope	N/A	Change modes as specified in Test 19 and check respective 'E' terminals on PCB assembly. Terminals must be HI for specified modes, and LOW for other modes.
M1E22		V dc	2.4	5.25	Oscilloscope	N/A	
M2E8		V dc	2.4	5.25	Oscilloscope	N/A	
M3E7		V dc	2.4	5.25	Oscilloscope	N/A	
MTE36		V dc	2.4	5.25	Oscilloscope	N/A	
MCE37		V dc	2.4	5.25	Oscilloscope	N/A	
T20	A	μs	47.8	57.0	Oscilloscope	10 $\mu\text{s}/\text{cm}$	Delay period referenced to 'To' trigger.
	B	μs	1.9	2.5	Oscilloscope	10 $\mu\text{s}/\text{cm}$	1st pulse width
	C	μs	12.9	18.0	Oscilloscope	10 $\mu\text{s}/\text{cm}$	Leading-edge of 1st pulse to leading-edge of 2nd pulse.

Table 3-2. Troubleshooting Analysis, Measurement Parameters (Cont)

TEST	PULSE	UNIT OF MEAS	MEASURED VALUE		TEST EQUIPMENT	CONTROL SETTINGS	REMARKS
			MIN	MAX			
T20 (Cont)	D	μs	0.8	1.5	Oscilloscope	10 $\mu s/cm$	2nd pulse width
T21	A	μs	65.0	78.0	Oscilloscope	10 $\mu s/cm$	Delay period referenced to 'To' trigger. Note only that a narrow strobe is present.
T22	A	μs	1.8	2.8	Oscilloscope	5 $\mu s/cm$	
	B	μs	14.3	16.3	Oscilloscope	5 $\mu s/cm$	Positions of pulses as designated.
	C	μs	0.8	1.4	Oscilloscope	5 $\mu s/cm$	
	D	μs	14.0	16.0	Oscilloscope	5 $\mu s/cm$	
	E	μs	17.0	20.0	Oscilloscope	5 $\mu s/cm$	
T23	A	μs	40.0	44.0	Oscilloscope	10 $\mu s/cm$	
	B	μs	10.0	12.0	Oscilloscope	10 $\mu s/cm$	Positions of pulses as designated.
	C	μs	3.8	4.8	Oscilloscope	10 $\mu s/cm$	
	D	μs	0.8	1.4	Oscilloscope	10 $\mu s/cm$	
T24		kHz	538.0	566.0	Electronic Counter	FREQUENCY SENSITIVITY = 1 V rms	Connect test point to counter.

Figure 3-1. Test Set, General Trouble Analysis Diagram (Sheet 1 of 2).
(Located in back of manual)

Figure 3-3. Test Set, General Trouble Analysis Diagram (Sheet 2 of 2).
(Located in back of manual)

Table 3-3. RF Section, Troubleshooting Analysis, Measurement Parameters

A1 TEST	PULSE	UNIT OF MEAS	MEASURED VALUE		TEST EQUIPMENT	CONTROL SETTINGS	REMARKS
			MIN	MAX			
					NOTE All tests Mode 2 Self-Test, Single Channel Code 0000 unless otherwise instructed.		Test points on track of RF module, figure 3-8.
T1	-	V dc	11.5	12.5	Digital Multimeter	As necessary	Check voltage between power supply TP1 and points shown on trouble analysis diagram, figure 3-2.
T2	-	V dc	4.75	5.25	Digital Multimeter	As necessary	Check voltage between power supply TP1 and points shown on trouble analysis diagram, figure 3-2.
T3	-	V dc	0.0	0.05	Digital Multimeter	As necessary	Check voltage between power supply TP1 and points shown on trouble analysis diagram, figure 3-2.
T4	-	V dc	0.4	0.6	Digital Multimeter	As necessary	Check voltage between power supply TP1 and points shown on trouble analysis diagram, figure 3-2.
T5	A	μs	0.9	-	Oscilloscope	5 μs/cm	Trigger EXT NEG 'To' U2TP4. Voltage level is TTL, maximum LOW = 0.3 V dc, minimum HI = 2.4 V dc.
T6	A	μs	0.6	1.0	Oscilloscope	2 μs/cm	Trigger as in T5, first pulse check only.
T7	FREQ	MHz	1029.8	1030.2	Oscilloscope Frequency Counter E/W Transfer Oscillator	Trigger as in T5 PLUG-IN 103 MHz N:10 APM-378 TEST switch to OFF	Setup as shown in figure 3-3. Adjust the transfer oscillator for a zero beat-frequency of any output pulse as observed on oscilloscope. Read frequency from counter.
	POWER (prelim step)				Oscilloscope Frequency Counter	+INT sync 0.2 V/Div 10 μs/Div Output Standard Frequency: 10 kHz	Setup as shown in figure 3-4 for T7 test. Measure width of positive pulse at U2TP8 (μs).
	POWER	dBm	+8 dBm	+15 dBm	Power Meter, Model 4017C/1	5 dBm scale % Efficiency, per calibration on power head	Connect power meter to test set. Calculate peak pulse power = measured average power (dBm) $+10 \log_{10} \frac{100}{\text{pulse width at U2TP8}^*}$
							Reconnect 1030 MHz cable after completion of test.

* Example: Suppose pulse width at U2TP8 is 33 μs, then $10 \log_{10} \frac{100}{33} = 10 \log_{10} 3.0 = 4.771$ to be added to measured average power.

Table 3-3. RF Section, Troubleshooting Analysis, Measurement Parameters (Cont)

A1 TEST	PULSE	UNIT OF MEAS	MEASURED VALUE		TEST EQUIPMENT	CONTROL SETTINGS	REMARKS
			MIN	MAX			
T8	FREQ	MHz	1059.8	1060.2	Frequency Counter E/W Transfer Oscillator	APM-378 TEST switch to ON	Setup as shown in figure 3-3. Adjust the transfer oscillator for a zero beat-frequency of any output pulse as observed on oscilloscope. Read frequency from counter.
					Oscilloscope	PLUG IN 106 MHz N:10 Trigger as in T5	
	POWER	dBm	+4 dBm	+15 dBm	Power Meter	APM-378 TEST switch to OFF	Setup as shown in figure 3-4 for T8 test. Remove U4 digital board. Connect power meter to test set. Calculate peak pulse power = measured average power (dBm)
					Frequency Counter	10 dBm scale % Efficiency, per calibration on power head Output Standard Frequency: 10 kHz	
							$+10 \log_{10} \frac{100}{\text{pulse width at U2TP8}^*}$
						APM-378 TEST switch to ON	Reconnect 1060 MHz cable and replace U4 digital board after completion of test.
T9	A	ms	7.6	8.0	Oscilloscope	1 ms/cm	Trigger as in T5. TTL voltage levels.
T10	A	μs	0.9	2.6	Oscilloscope	1 μs/cm	Trigger as in T5. First pulse check only.
V1	-	V dc	0.5	1.5	Oscilloscope		
V2	-	V dc	4.5	5.25	Oscilloscope		
T11	A	μs	0.9	2.6	Oscilloscope	1 μs/cm	Trigger as in T5. TTL voltage levels, first pulse check only.
T12							
	V2	V dc	0.4	1.0	Oscilloscope		Must be constant dc level for SELF TEST, SINGLE CHANNEL.
	A	ms	7.6	8.0	Oscilloscope	1 ms/cm	Change FUNCTION switch to SYSTEM. Change SYSTEM TYPE switch to DIVERSITY. Trigger as in T5.
							NOTE
							Observe period A, and V1 and V2 voltage levels.

* As measured in T7 test.

Table 3-3. RF Section, Troubleshooting Analysis, Measurement Parameters (Cont)

A1 TEST	PULSE	UNIT OF MEAS	MEASURED VALUE		TEST EQUIPMENT	CONTROL SETTINGS	REMARKS
			MIN	MAX			
T12 (Cont)							
V1	-	V dc	0.0	0.05	Oscilloscope	--	
V2	-	V dc	0.4	1.0	Oscilloscope	--	
T13							
LOW		V dc	0.0	0.8	Oscilloscope	--	<p>Check for low level voltage in SELF TEST, SINGLE CHANNEL. Change FUNCTION switch to SYSTEM. Change SYSTEM TYPE switch to DIVERSITY and check for HI level voltage.</p> <p>NOTE</p> <p>An alternating signal may be present in low level check. Unit is satisfactory if this signal does not exceed 0.8 V.</p>
HI		V dc	2.4	5.25	Oscilloscope	--	
T14							<p>Turn off power to test set. Unsolder lead to A1U2 DIV GATE. Connect a 100 Ω 1/4W resistor between DIV GATE printed circuit track and ground. Turn power ON.</p> <p>Must be constant dc level for SELF TEST, SINGLE CHANNEL.</p> <p>Change FUNCTION switch to SYSTEM. Change SYSTEM TYPE switch to DIVERSITY. Trigger as in T5.</p> <p>Turn off power to test set and disconnect 100 Ω resistor and reconnect A1U2 DIV GATE lead to track.</p>
V2	-	V dc	0.6	1.6	Oscilloscope		
	A	ms	7.6	8.9	Oscilloscope	1 ms/cm	
V1	-	V dc	0.0	0.1	Oscilloscope	--	
V2	-	V dc	0.6	1.6	Oscilloscope	--	
T15							<p>Turn on power. Must be a constant ground voltage level for SELF TEST, SINGLE CHANNEL. Change SYSTEM TYPE switch to DIVERSITY. Trigger as in T5.</p> <p>NOTE</p> <p>Observe period A, and V1 and V2 voltage levels.</p>
V1	-	V dc	0.0	0.05	Oscilloscope		
	A	ms	7.6	8.0	Oscilloscope	1 ms/cm	
V1	-	-	0.0	0.05	Oscilloscope	--	
V2	-	-	0.4	1.0	Oscilloscope	--	
T16							<p>Turn off power to test set. Unsolder lead to A1U2 NORM GATE. Connect a 100 Ω 1/4W resistor between the NORM GATE printed circuit track and ground.</p>

Table 3-3. RF Section, Troubleshooting Analysis, Measurement Parameters (Cont)

A1 TEST	PULSE	UNIT OF MEAS	MEASURED VALUE		TEST EQUIPMENT	CONTROL SETTINGS	REMARKS
			MIN	MAX			
T16 (Cont)							
V1	-	V dc	0.0	0.1	Oscilloscope		Turn on power. Must be a constant ground voltage level for SELF TEST, SINGLE CHANNEL, Change SYSTEM TYPE switch to DIVERSITY. Trigger as in T5. NOTE Observe period A, and V1 and V2 voltage levels. Disconnect 100 Ω resistor and reconnect A1U2 NORM GATE lead to track.
	A	ms	7.6	8.0	Oscilloscope	1 ms/cm	
V1	-	-	0.0	0.1	Oscilloscope	--	
V2	-	-	0.6	1.6	Oscilloscope	--	
T17	Diode Continuity Test				Digital Multimeter	1 kΩ	Turn off power to test set. Unsolder lead to A1U2 NORM VIDEO and check continuity between A1U2 NORM VIDEO and ground, for both polarity lead connections - 0.8 volt ±10% in one direction, 0.47 volt ±10% in the other direction.
T18	Diode Continuity Test				Digital Multimeter	1 kΩ	Turn off power to test set. Measure continuity of base-emitter junction, from A1U3 NORM VIDEO to ground, for both polarity lead connections - low impedance in one direction (0.4 V to 1.4 V) high impedance in the other direction (meter overrange).
T19 T20	Diode Continuity Test				Digital Multimeter	1 kΩ	Perform same steps as for steps T17 and T18, but measure at A1U2 DIV VIDEO and A1U3 DIV VIDEO points. Voltages same as for steps T17 and T18.
T21	FREQ	MHz	30 nominal		Oscilloscope	10 n-Sec/div 2 mV/div INT sync	Set up as shown in figure 3-5. Turn test set power OFF. Solder a 50-ohm coaxial cable to A1U2 30-MHz output, and clip or solder coaxial shield to the ground plane (see track layout figure 3-8). Connect BNC end of coaxial cable to the oscilloscope and turn on test set power. Remove U4 digital board and ground U3TP5 and U2TP9. Adjust oscilloscope to display a stable pattern. Observe that the frequency is 30 MHz (33 ns between peaks). A precise measurement is not required.
	POWER	dBm	-40 dBm	-			Verify that the peak-to-peak voltage of the signal is 0.003 volts or more (= -40 dBm into 50 Ω load minimum). Turn off power and unsolder coaxial cable from A1U2. Reassemble RF Module and test set.

Figure 3-2. RF Section, Trouble Analysis Diagram. (Located in back of manual).

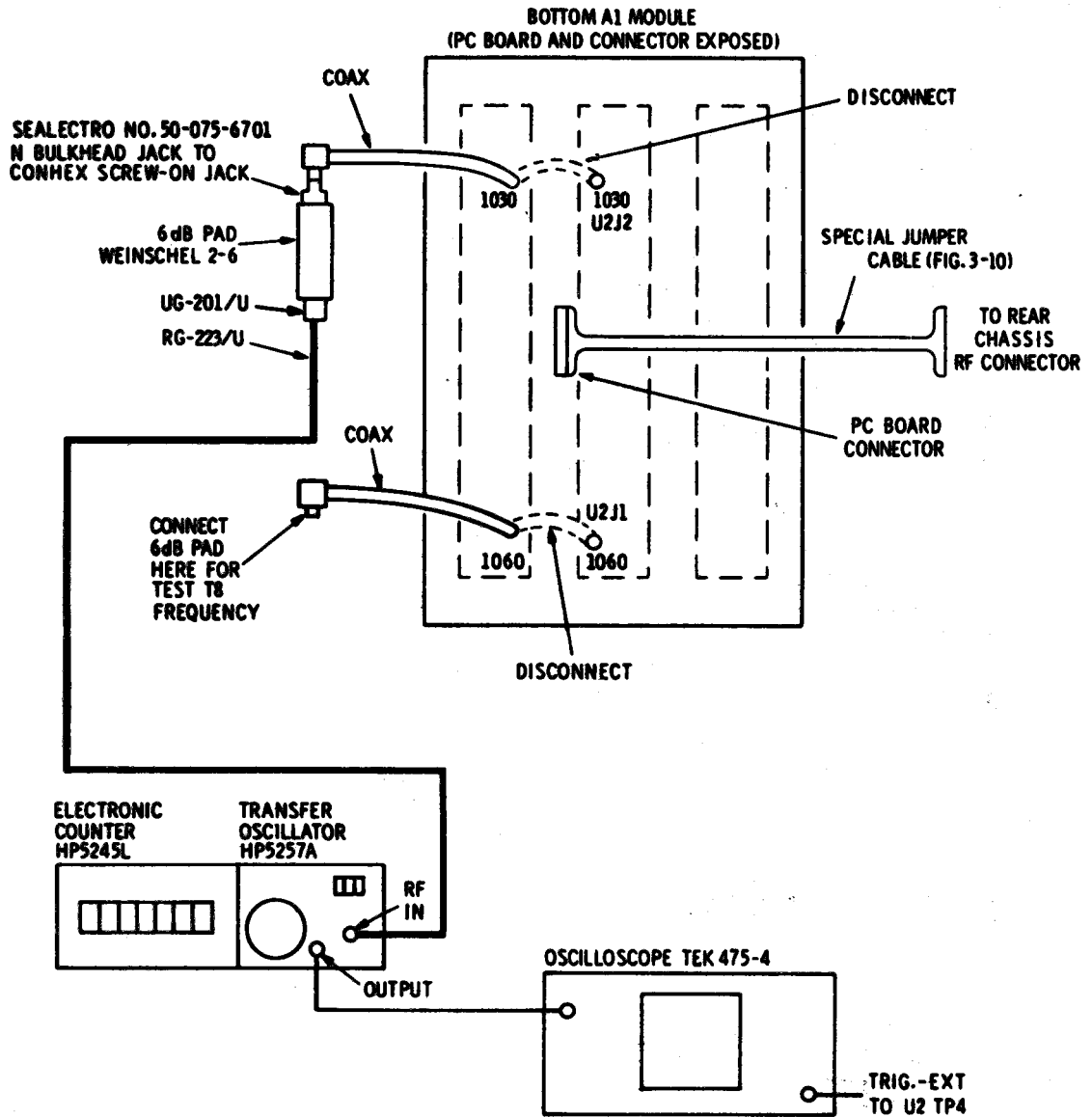

069-002-028B

Figure 3-3. RF Module, Setup Diagram for T7 and T8 Frequency Tests

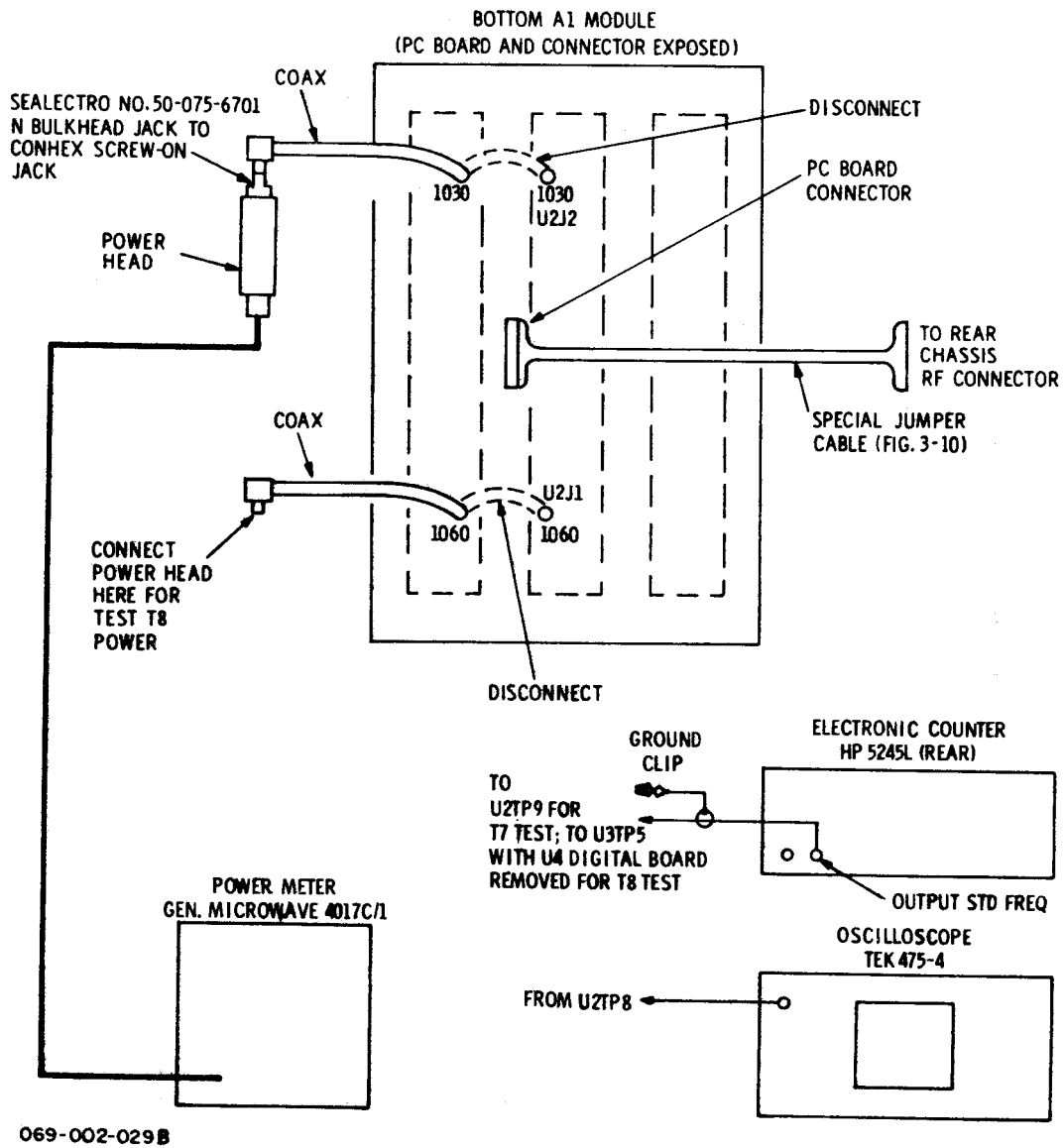

Figure 3-4. RF Module, Setup Diagram for T7 and T8 Power Tests

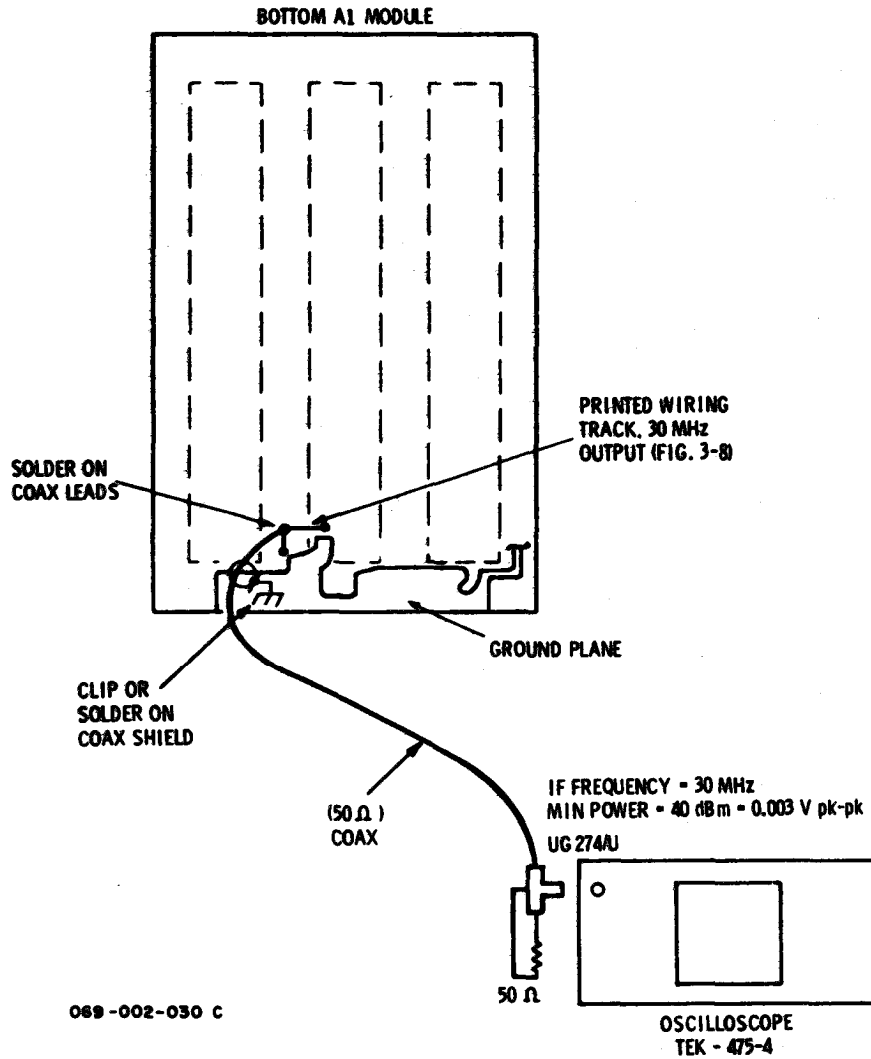

Figure 3-5. RF Module, Test T21 Setup Diagram

3-27. INSPECTION.

3-28. No special inspection procedures are required for the test set. Table 3-4 lists certain types of defects which can be checked for, during normal servicing of the equipment, or during normal usage.

3-29. REPAIR.

3-30. The test set uses nonreparable module assemblies for most of its circuits. Repair of the equipment is accomplished by replacement of the faulty digital module or submodule of the rf module assembly. The only other repair to the equipment consists of normal type replacement of piece parts on the chassis and front-panel assemblies. No unconventional techniques are required for these repairs.

3-31. LIMITS.

3-32. There are no specific limits of wear and tolerances for the mechanical portions of this test set. Replacement or servicing should be accomplished whenever wear causes incorrect operation, confirmed by the intermediate testing procedures of Section 4.

3-33. ASSEMBLY.

3-34 Assembly of the components of the equipment, following disassembly and repair, is in most cases obvious from reference to the illustrations of Section 6 (IPB), and to the hardware itself. Care should be

exercised when inserting the printed-circuit modules into their positions in the card cage, to prevent damage to the connectors, and ensure that they are fully seated in their connectors. Match the module reference designators marked on each module with its marked-slot in the card cage.

3-35. When assembling the case to the front panel/chassis assembly, use care to prevent damage to the sealing gasket between them. Before reassembly of these items, perform the calibration checkout and adjustment procedures, if required.

3-36. ADJUSTMENT.

3-37. Adjustment of the test set consists of potentiometer adjustments in the rf module A1. These adjustments control the receiver sensitivity, and the transmitter power of the circuits. These adjustments should be made only in conjunction with the calibration procedures,

3-38. TESTING AND CALIBRATION.

3-39. Intermediate testing procedures for checkout after repair are contained in Section 4. For calibration, refer to TB 11-4920-296-45 (to be published).

Table 3-4. Inspection Suggestions

ITEM	DEFECT
Mechanical	Broken knobs, switches Stiff or erratic movement Missing or damaged seals Broken wiring, contacts Bent contacts Missing mounting hardware
Electrical	Evidence of arcing/shorting Broken printed circuit tracks Broken wiring Damaged contacts Damaged potting Damaged lamps Corrosion of contacts

3-40. WIRING/SCHEMATIC DATA.

3-41. Table 3-5 through 3-8 contain wire list data for the test set. Figures 3-6 through 3-9 provide schematic/wiring diagrams for the PCB assemblies, power supply circuits and front panel mounted components. The functional block diagram of

figure 2-3 gives the interconnecting details of the R F module and the RF section to the front panel components and to the power supply circuits. The three sheets of figure 3-10 give the fabrication and wiring details for the special jumper cable that is required for rf circuits maintenance.

Table 3-5. Transponder Set Test Set AN/APM-378, Wiring List (Interconnections between Chassis/Panel Assembly Components)

FROM	TO	FROM	TO
CB1-1	E49, J1-L	E19	S1-4
CB1-2	FL1-1	E20	S2-2
CB2-1	J1-N, T1-2	E21	S8-12
CB2-2	FL2-1	E22	S9-1
CB2-3	J1-R, T1-4	E23	S8-11
CB2-4	FL3-1	E24	J1-J
DS1-1	E51B	E25	S8-2, S7-B
DS1-2	DS4-2, DS2-2, E46	E26	J1-G
DS2-1	E11, J1-a	E27	DS3-1
DS2-2	E46, U6-2, DS2-2	E28	J1-C
DS3-1	E27	E29	J1-E
DS4-1	E42	E31	S9-B
E1	S3-1	E32	S2-1
E2	S4-4	E33	S1-1
E3	S3-4	E34	S4-1
E4	S1-2	E35	S1-C
E5	S2-4	E36	S9-5
E6	S4-C	E37	S9-4
E7	S9-3	E38	S9-6
E8	S9-2	E39	J1-S
E9	S6-1	E40	J1- <u>C</u>
E10	S7-3	E41	S8-1
E11	DS2-1	E42	DS4-1
E12	S8-4	E43	S5-1
E13	S7-1	E44	S7-8
E14	J1-A	E46	U6-2, TP2, DS2-2
E16	R-3	E47	U7-2, TP3
E17	S4-2	E48	E50A
E18	S3-2	E49	CB1-1

Table 3-5. Transponder Set Test Set AN/APM-378, Wiring List (Cont)
(Interconnections between Chassis/Panel Assembly Components)

FROM	TO	FROM	TO
E50	E51A, TP1, E48	J2-A	FL1-2
E51A	J1-H, B, F, d, E50, FL4-1	J2-B	FL2-2
E51B	J1-h, T, K, D, E50, S10-3 S11-1, DS1-1	J2-C	E52
E 52	J2-C	J2-D	FL4-2
FL1-1	CB1-2	J2-E	FL3-2
FL1-2	J2-A	R1	U6-1
FL2-1	CB2-2	R1	C1(+)
FL2-2	J2-B	R2	U7-1
FL3-1	CB2-4	R3	E16, S8-A
FL3-2	J2-E	S1-1	E33
FL4-1	E51A	S1-2	E4
FL4-2	J2-D	S1-4	E19
J1-A	E14	S1-C	E35
J1-B	E51A	S2-1	E32
J1-C	E28	S2-2	E20
J1-D	E51B	S2-4	E5
J1-E	E29	S3-1	E1
J1-F	E51A	S3-2	E18
J1-G	E26	S3-4	E3
J1-H	E51A	S4-1	E34
J1-J	E24	S4-2	E17
J1-K	E51B	S4-4	E2
J1-L	CB1-1	S4-C	E6
J1-N	CB2-1	S5-1	E43
J1-R	CB2-3	S5-2	S9-A, S7-A
J1-S	E39	S6-1	E9
T1-T	E51B	S6-2	S7-4
J1-V	S10-2	S7-1	E13
J1-X	S11-2	S7-3	E10
J1-a	DS2-1	S7-4	S6-2
J1-c	E40	S7-8	E44
J1-d	E51A	S7-A	S5-2, S9-A
J1-h	E51B	S7-B	S8-2, E25
		S8-A	R-3

Table 3-5. Transponder Set Test Set AN/APM-378, Wiring List (Cont)
(Interconnections between Chassis/Panel Assembly Components)

FROM	TO	FROM	TO
S8-B	S9-7	S9-B	E31
S8-1	E41	S10-2	J1-V
S8-2	E25, S7-B	S10-3	E51B, S11-1
S8-4	E12	S11-1	S10-3, E51B, DS1-1
S8-11	E23	S11-2	J1-X
S8-12	E21	T1-2	CB 2-1
S8-A	S6-2, E16	T1-4	CB 2-3
S8-B	S9-7	TP1	E50
S9-1	E22	TP2	E46, U6-2, DS2-2
S9-2	E8	TP3	E47, U7-2
S9-3	E7	U6-1	R1
S9-4	E37	U6-2	E46, TP2, DS2-2
S9-5	E36	U7-1	R2
S9-6	E38	U7-2	E47, TP3
S9-7	S8-B		
S9-A	S5-2, S7-A		

Table 3-6. Cable Assembly W3, Wiring Data

FROM	TO	FROM	TO
W3P1-	W3P2-	W3P1-	W3P2-
<u>e</u> , d	1	a	14
E, F	3	N	15
C, D	4	R	16
A, B	6	V	19
G, H	7	T	24
J, K	8	L	31
X	9	h	34
S	12, 13		20 jumpered to 26

Table 3-7. Multipin Connectors J1 and J2, Pin Functions

J1 -- MODE-4 CONNECTOR

PIN	FUNCTION	PIN	FUNCTION
A	TDV	N	115 V ac Power
B	Ground	R	115 V ac Power
C	M4 PRETRIGGER	S	COMPUTER
D	Ground	T	Ground
E	M4 VIDEO	V	VERify BIT 1
F	Ground	X	CODE A/B Select
G	M4 REPLY VIDEO	a	CODE ZEROIZE lamp
H	Ground	c	M4 SL
J	M4 GTC	d	Ground
K	Ground	h	Ground
L	+28 v dc Power		

J2 -- POWER Connector

A	+28 V dc Power input	D	28 V dc Return
B	115 V dc Input (one side)	E	115 V ac Input (second side)
C	Safety Ground (for 115 V ac Input)		

Table 3-8. RF Module A1, Coaxial Cable Connections

A1U2 CONNECTOR	CONNECTION
J1 (bottom of module)	A1U1P1, from Oscillator/LO Module
J2 (bottom of module)	A1U1P2, from Oscillator/LO Module
J1 (side of module)	W7P1, from DIRECT TEST-NORMAL jack J3
J2 (side of module)	W8P1, from RADIATED TEST ANTENNA jack J5

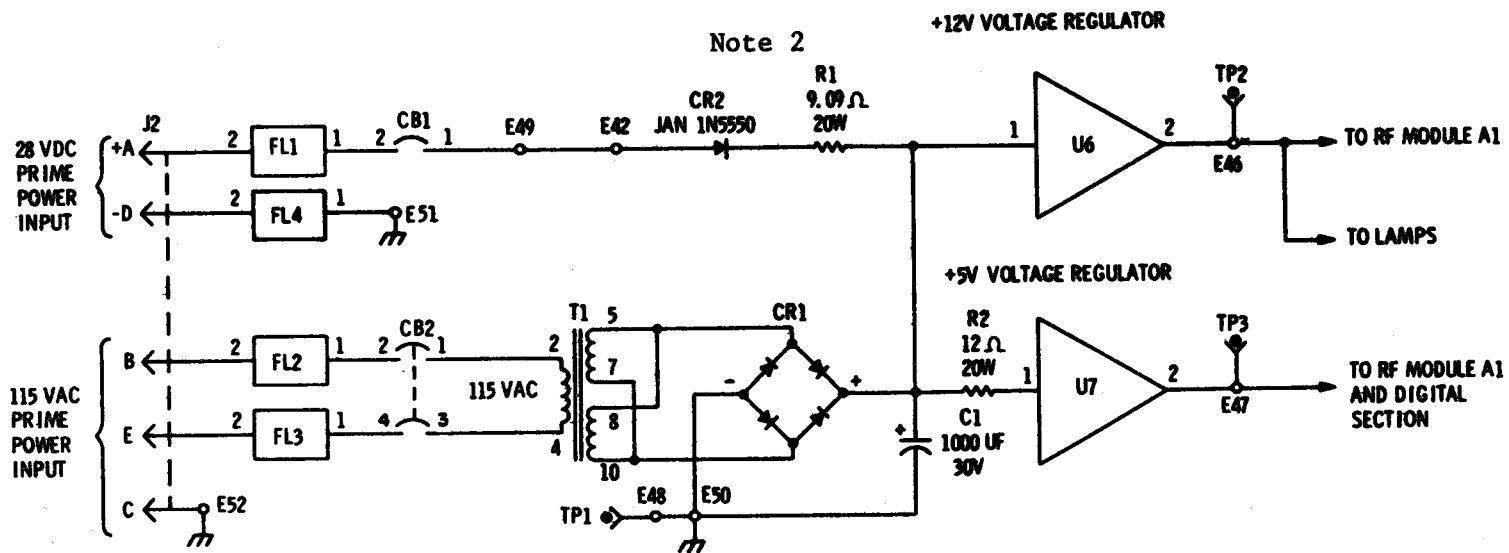

069-002-0178

NOTES:

1. All resistors are 1% tolerance.
2. Diode IN5550, 200 volt peak (Rev.)
3Amp (Forward).

■ Figure 3-6. Power Supply Circuits, Schematic Diagram

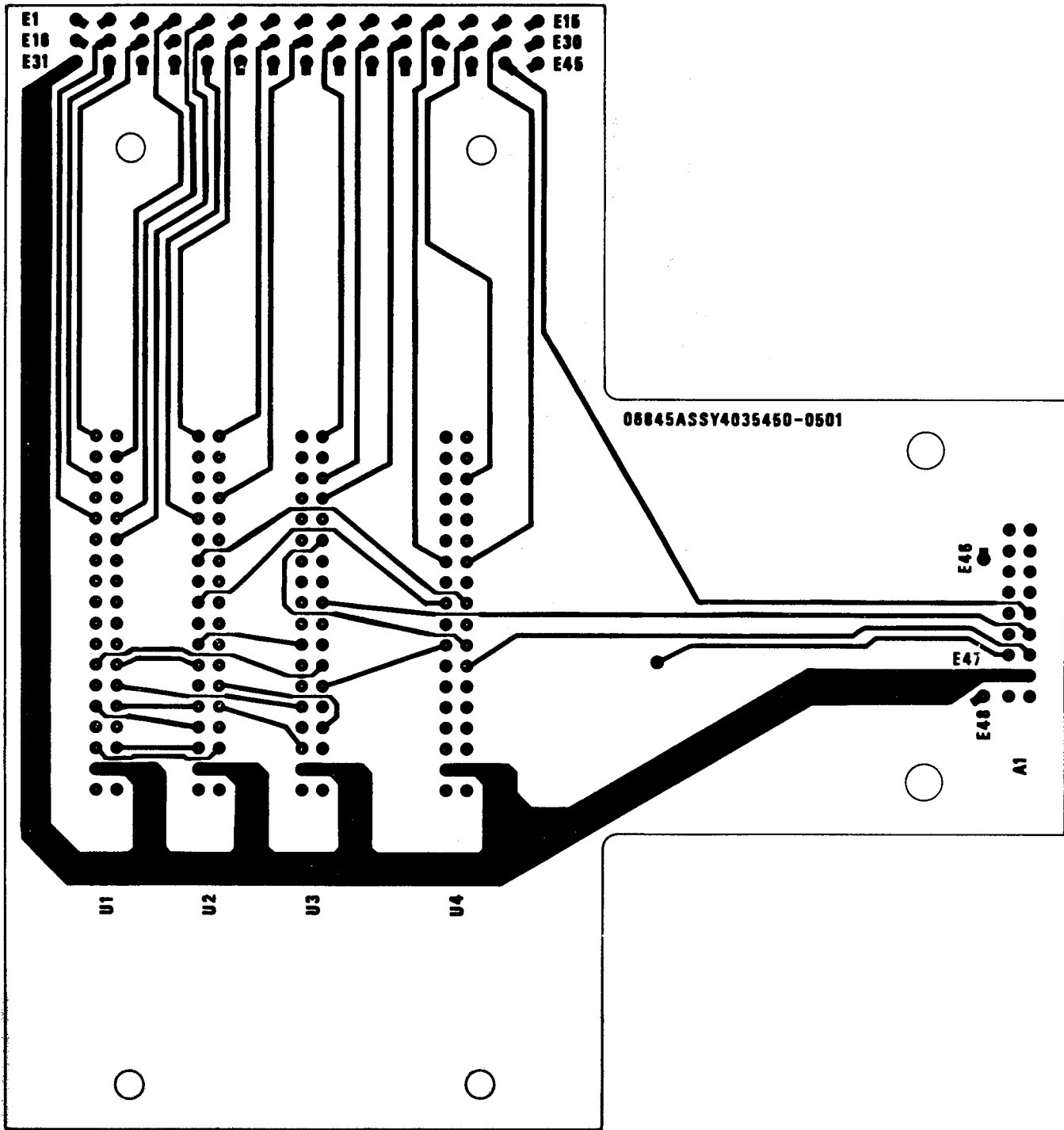

069-002-018.1

Figure 3-7. Motherboard, Track Wiring, Schematic Diagram
(Sheet 1 of 2)

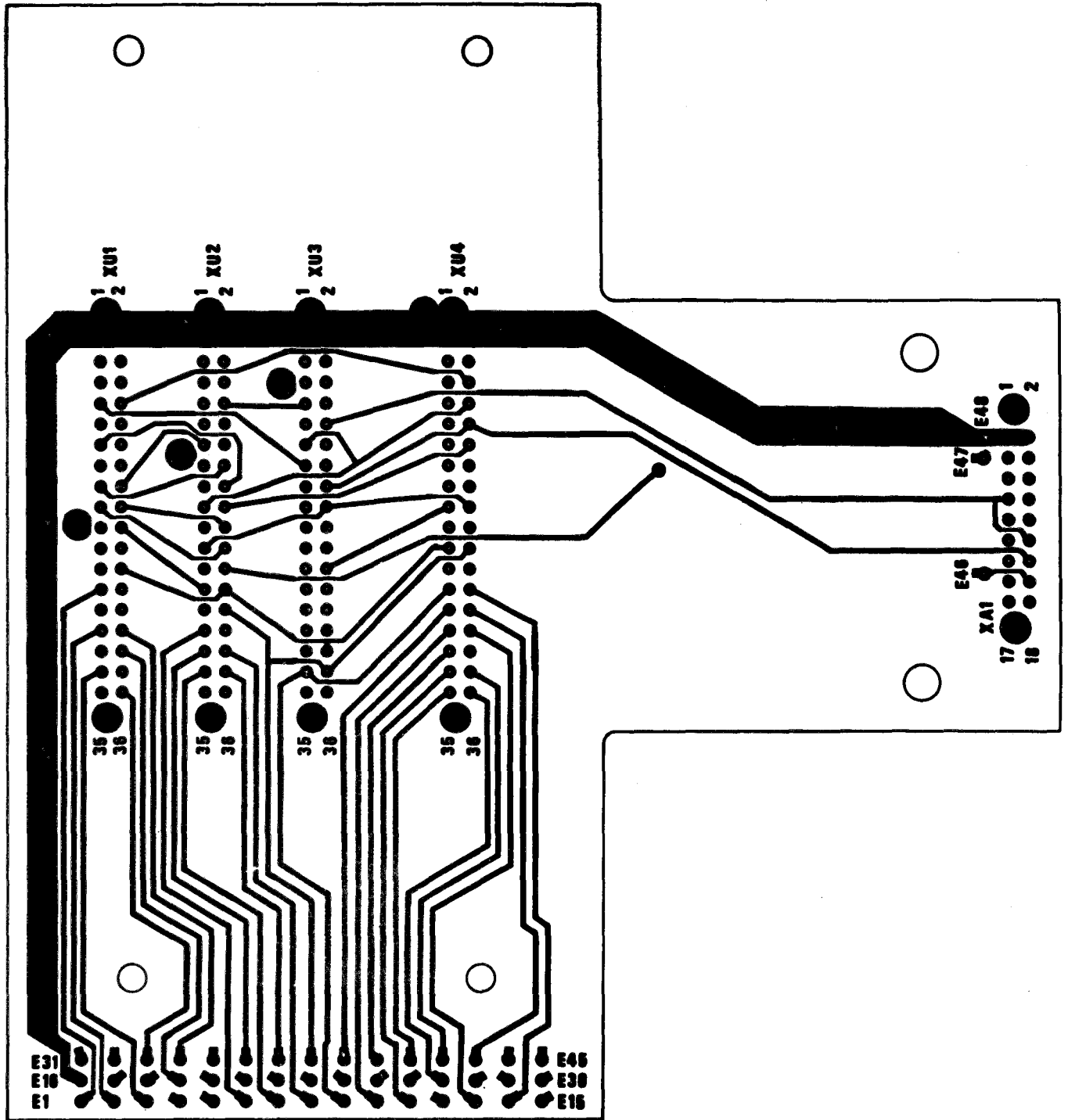

069-002-018.2A

Figure 3-7. Motherboards, Track Wiring, Schematic Diagram
(Sheet 2 of 2)

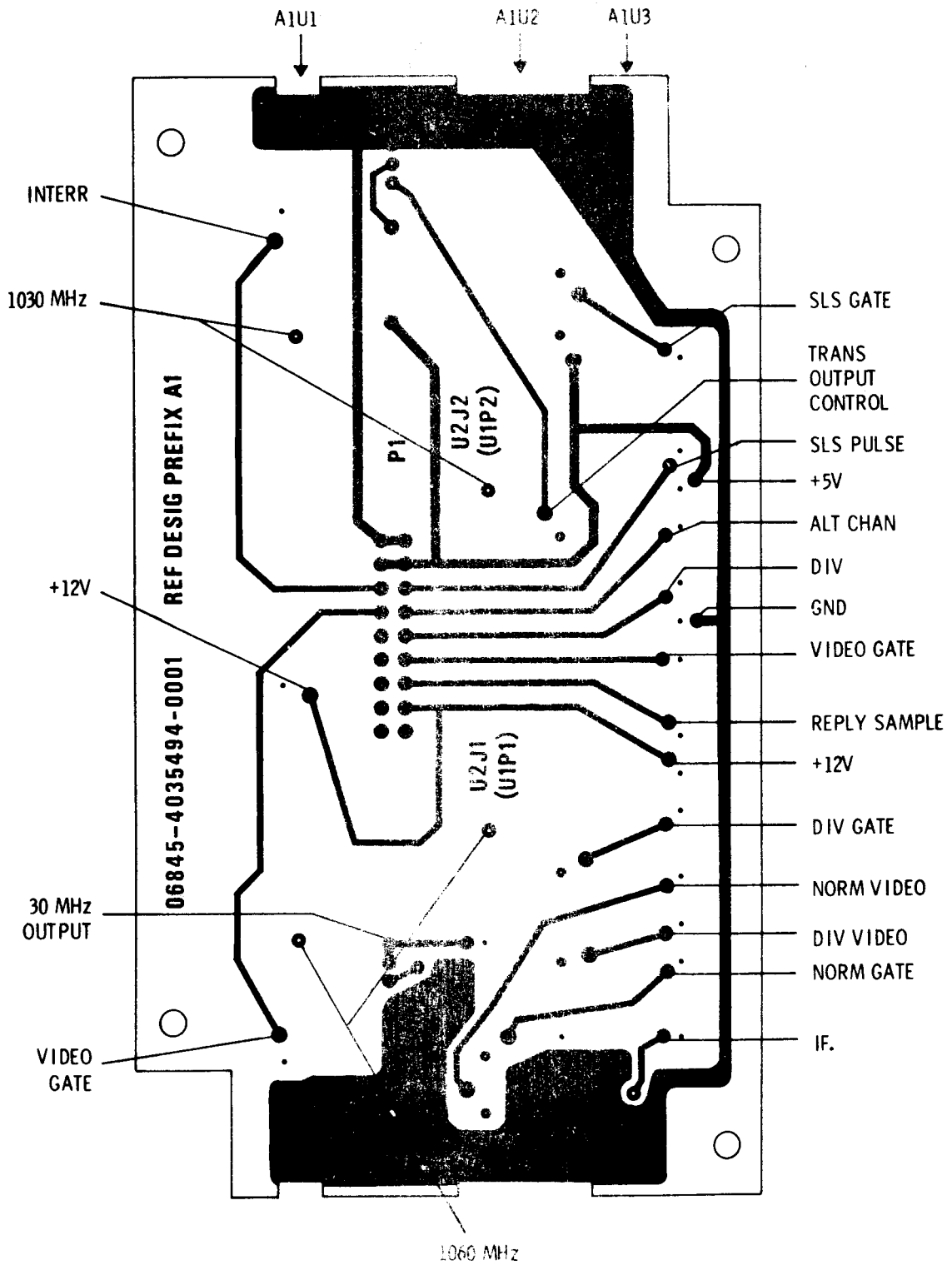

069-002-019

Figure 3-8. RF Module A1 PCB Track Wiring Diagram

Figure 3-9. Transponder Set, Test Set AN/APM-378, Front Panel Schematic Diagram. (Located in back of manual).

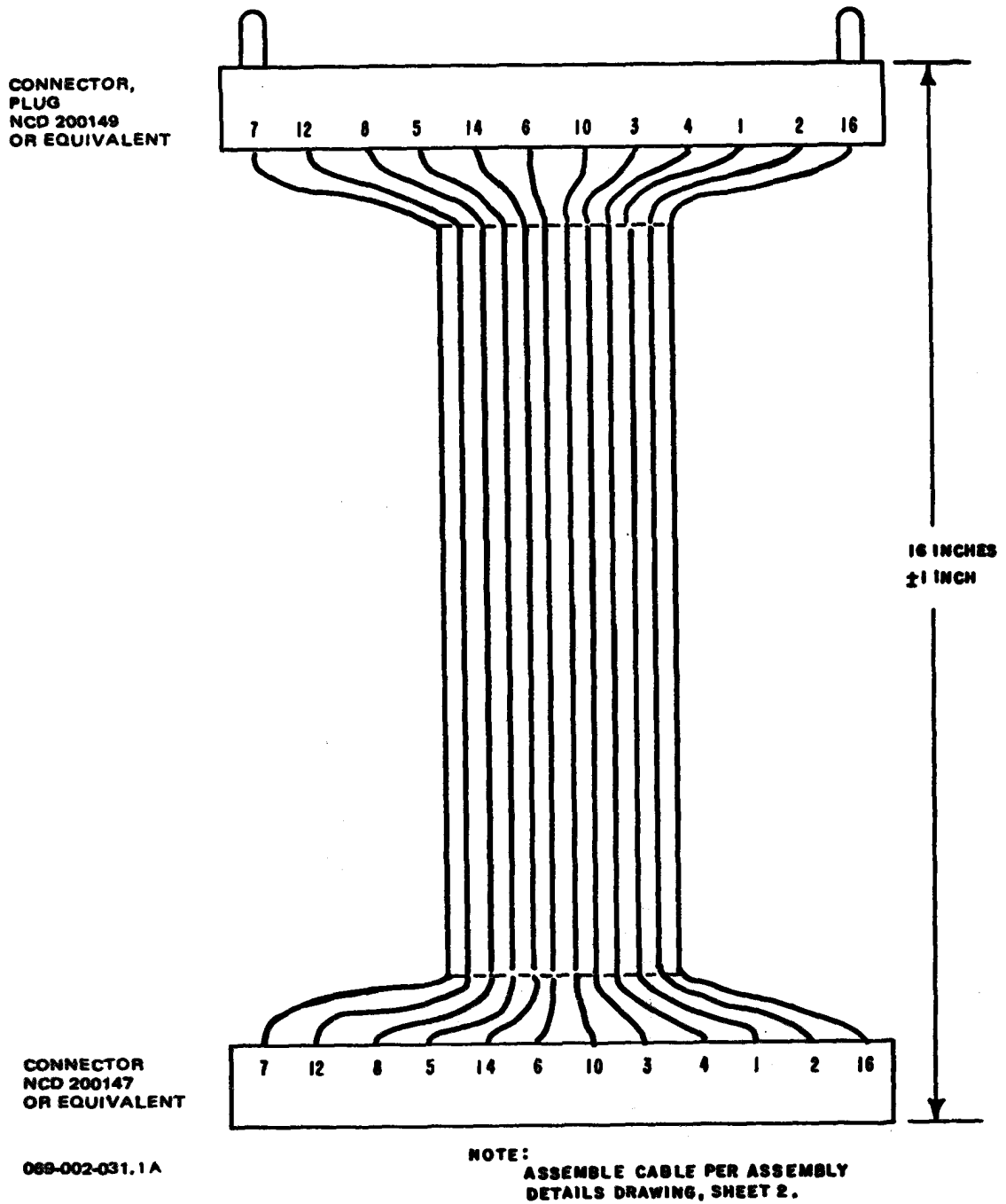
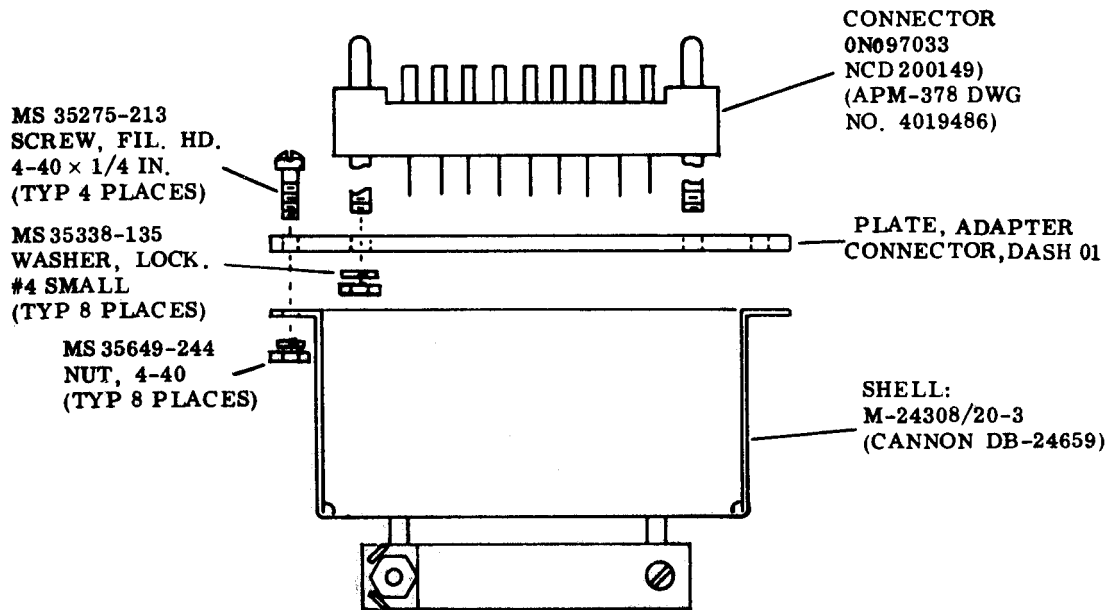
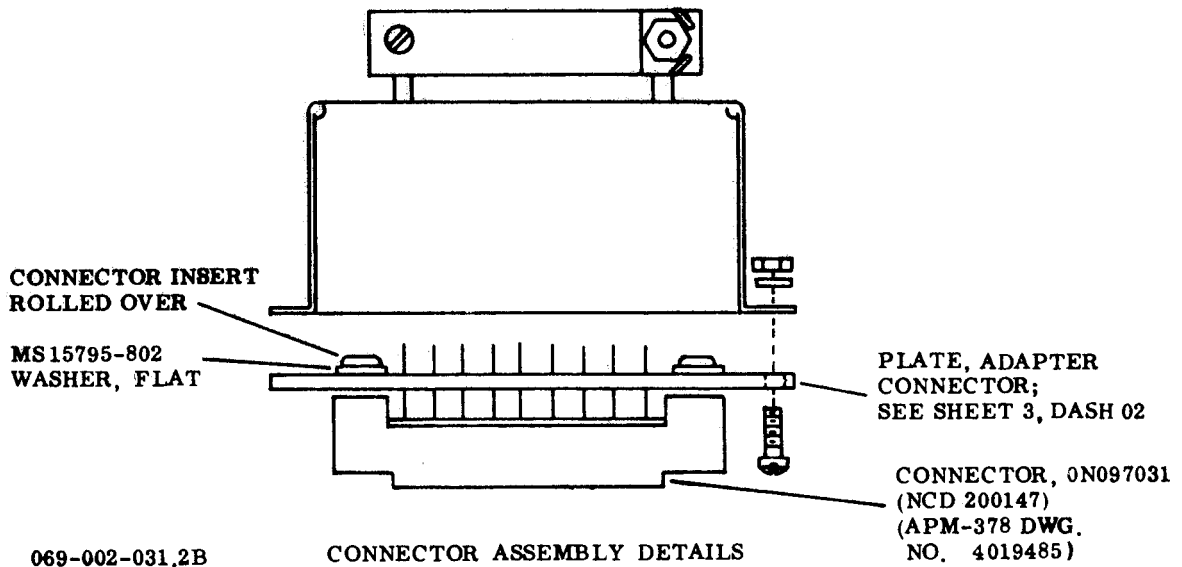

Figure 3-10. Special Jumper Cable for RF Circuits Maintenance
(Sheet 1 of 3)



NOTE:
SEE SHEET 1 DRAWING
FOR CABLE WIRING.



069-002-031.2B

CONNECTOR ASSEMBLY DETAILS

Figure 3-10. Special Jumper Cable for RF Circuits Maintenance
(Sheet 2 of 3)

MATERIAL: Glass-filled epoxy resin sheet,
NEMA G-10, 1/16th inch thick,
or equivalent.

DASH	HOLE "a"	HOLE "b"
-01	0.136 ± 0.003	0.136 ± 0.003
-02	0.136 ± 0.003	0.109 ± 0.003

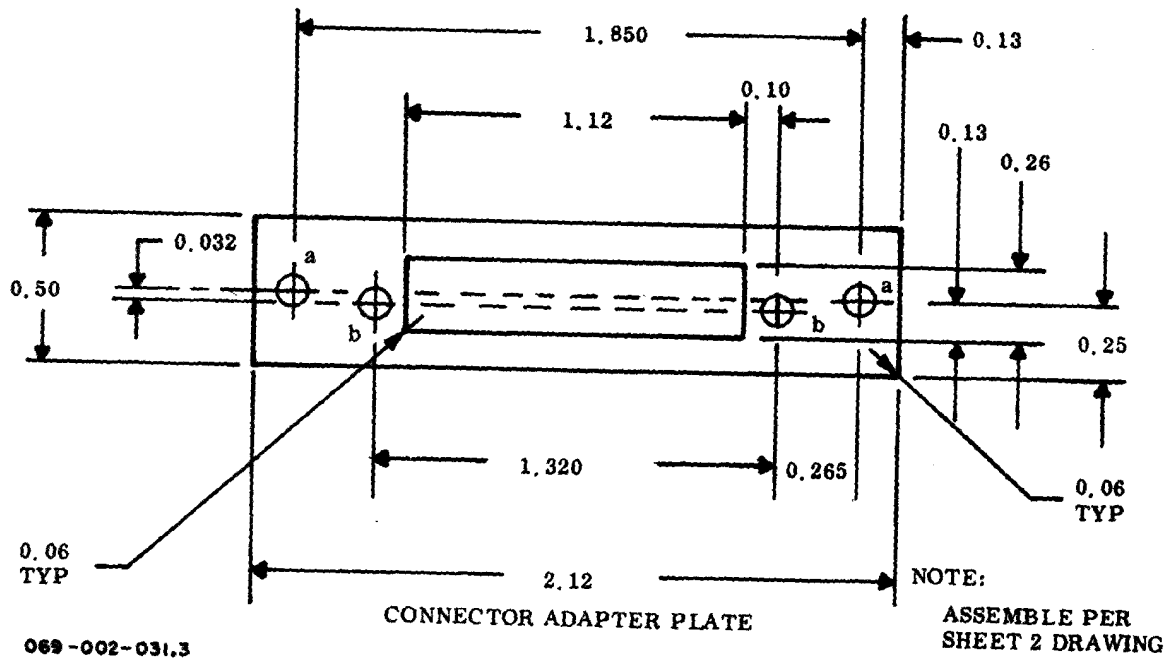

Figure 3-10. Special Jumper Cable for RF Circuits Maintenance
(Sheet 3 of 3)

SECTION 4

INTERMEDIATE TESTING PROCEDURES USING RADAR TEST SET AN/TPM-25A

4-1. GENERAL

4-2. This section contains the intermediate testing procedures and instructions for Transponder Set Test Set AN/AW-378. Information is included to check out the main functions of the test set.

4-3. TEST EQUIPMENT REQUIRED

4-4. Table 4-1 lists the test equipment required for intermediate testing procedures of the test set.

4-5. INTERMEDIATE CHECKOUT PROCEDURES

4-6. Table 4-2 lists the AN/TPM-25A standard switch settings for tests conducted on the AN/APM-378. Individual tests will indicate change from this listed standard.

4-7. Table 4-3 lists the test and procedures required for confirming that the test set is operating correctly. Figures 4-1 and 4-2 provide various test setups used in conjunction with the procedures of table 4-3. These checks should be performed after repair actions. The intermediate checkout is divided into sections which check for: (1) Power supply voltages; (2) Receiver sensitivity; (3) Receiver frequency and bandwidth; (4) Receiver reference code, emergency and I/P function, (5) Transmitter power; (6) Transmitter frequency; and (7) Transmitter plus characteristics. If

abnormal indications are observed for the receiver sensitivity check (2), or for the transmitter power check (5), refer to table 4-4 and make the appropriate adjustments. If the adjustment procedure cannot be correctly performed or if other indications are incorrect, proceed to Section 3, paragraph 3-9 Troubleshooting, to isolate that faulty module.

4-8. Mode 4 testing procedures of the test set will be performed at the end of the table 4-3 in the checkout procedures numbered 8-11. and 4-4 give the corresponding test setups. These Mode 4 checks are: (8) Pretrigger; (9) Interrogation video; (10) SLS pulse; and (11) GTC signal. Figure 4-5 provides the fabrication and wiring details for the Mode 4 connector.

4-9. If all are correct (as indicated in table 4-3), and the AN/APM-378 responds correctly to all of the input signals designated, the AN/APM-378 test set is proven to be fully operational.

4-10. The preliminary Tests and Preliminary Setup given in table 4-3 allow adequate warm-up time for the test set; make preliminary lamp tests and control settings prior to actually performing operational checkout. After the preliminary procedures/tests have been performed the intermediate checkout procedures may be performed.

TABLE 4-1. Transponder Set Test Set AN/APM-378,
Test Equipment Required

QTY	NAME	MIL TYPE NO./MFR & MODEL NO.
1	Radar Test Set	AN/TPM-25A
1	Oscilloscope	AN/USM-281A
1	Pulse Generator	AN/UPM-15A
1	Circulator	M3B-1020(96341)
1	Voltmeter, Digital	AN/GSM-64B

Table 4-2. Radar Test Set AN/TPM-25A Controls

	CONTROL	POSITION
1	Power ON/OFF switch	ON
2	SIG GEN NORM/INTERLEAVE switch	NORM
3	SUM ATTN control	0
4	DIFF/INTERLEAVE ATTN control	0
5	SIG GEN FUNCTION switch	FIXED FREQ
6	MEASUREMENT FUNCTION SEL switch	PWR
7	MEASUREMENT PRF RANGE	X100
8	MEASUREMENT FREQ MEAS control	5.0
9	MEASUREMENT DEMOD VID LEVEL control	Midrange
10	REPLIES MODULATION SEL switch	SIF
11	REPLIES REPLY WIDTH SELECT switch	0.45
12	REPLIES REPLY WIDTH VARY control	Midrange
13	REPLIES SIF REPLY CODE select switches	7700
14	REPLIES SUB PULSE SEL switch	OFF
15	REPLIES SUB PULSE POS SELECT switch	0
16	REPLIES SUB PULSE POS VARY control	Midrange
17	REPLIES RANGE DELAY SEL (USEC)switches	0001
18	REPLIES M4 JAMMING switch	0
19	REPLIES GATING PASS switches	00
20	REPLIES GATING INHIB switches	00
21	PRT SEL (USEC) switches	0500
22	TRIG SEL DCD MODE SEL switch	Mode 2
23	TRIG SEL INT/DCD/EXT switch	DCD
24	SIF CHAL VID SIF MODE SEL switch	OFF
25	SIF CHAL VID 5V/20V switch	5V
26	BIT (MOM) switch	Deactivated

Table 4-3. Transponder Set Test Set AN/APM-378, AN/TPM-25 Procedures

PROCEDURES	TEST EQUIPMENT CONTROL SETTINGS	CORRECT INDICATIONS/ MEASUREMENTS
PRELIMINARY SETUP		
<ol style="list-style-type: none"> 1. Remove front panel and chassis assembly from case. 2. Position equipment on workbench for access to both front panel, and rear chassis items. 3. Connect power (either 115V ac or 28 V dc) to unit. 4. Set AN/APM-378 controls as follows: <ul style="list-style-type: none"> MODE switch to 2 REFERENCE CODE switches to 7700 FUNCTION switch at SYSTEM SYSTEM TYPE switch SINGLE CHANNEL POWER switch (as applicable) to ON. 5. Allow 30-second warmup, then place the TEST switch to ON. 		<p>REJECT lamp will now be lit.</p>

Table 4-3. Transponder Set Test Set AN/APM-378, AN/TPM-25 Procedures

PROCEDURES	TEST EQUIPMENT CONTROL SETTINGS	CORRECT INDICATIONS/ MEASUREMENTS
PRELIMINARY TESTS		
<p>6. Place FUNCTION switch to LAMP TEST position.</p> <p>7. Place FUNCTION switch to SELF TEST position, and rotate MODE switch through all positions.</p> <p>8. With MODE switch in any of its positions, place TEST switch in MOM position.</p> <p>9. Return all test set controls to positions designated in steps 4 and 5 above.</p>		<p>All front panel lamps lit.</p> <p>ACCEPT lamp lights for each mode checked.</p> <p>ACCEPT lamp lights.</p> <p>REJECT lamp will now be lit.</p>
(1) POWER SUPPLY VOLTAGE CHECKS		
<p>10. Connect test set and test equipment as shown in figure 4-1.</p> <p>11. Set Digital Multimeter AN/GSM-64B for measuring indicated voltage, and connect meter probes to points indicated.</p>	<p>Digital Multimeter connected to measure:</p> <p>TP1 to chassis ground</p> <p>TP3 to TP1</p> <p>TP2 to TP1</p>	<p>0.0 ± 50 mV dc</p> <p>$+5.0 \pm 0.25$ V dc</p> <p>$+12.0 \pm 0.5$ V dc</p>

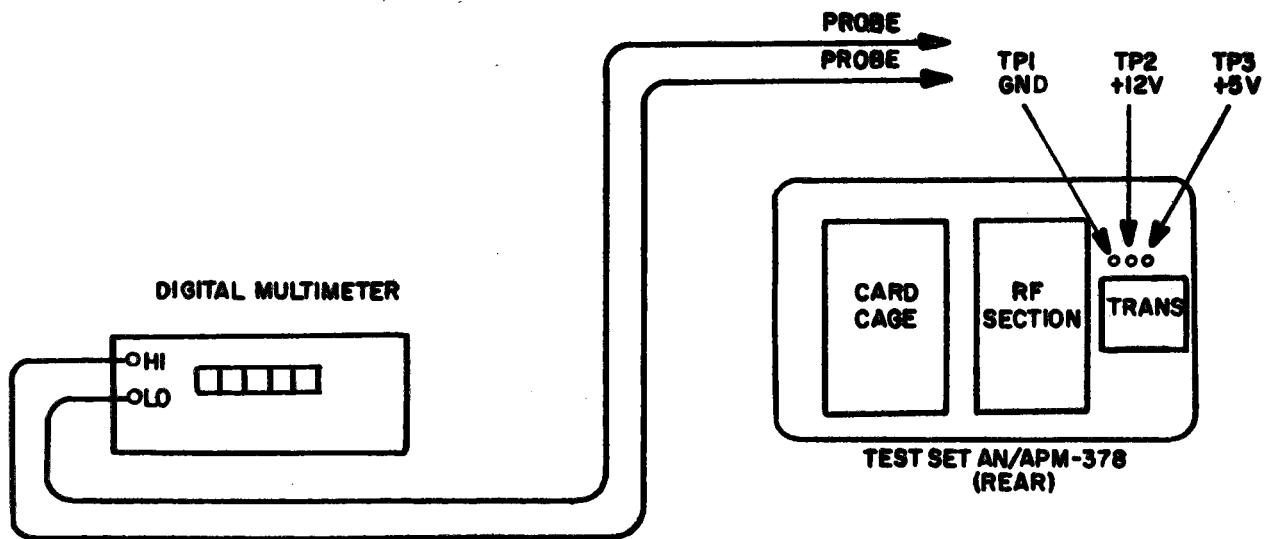
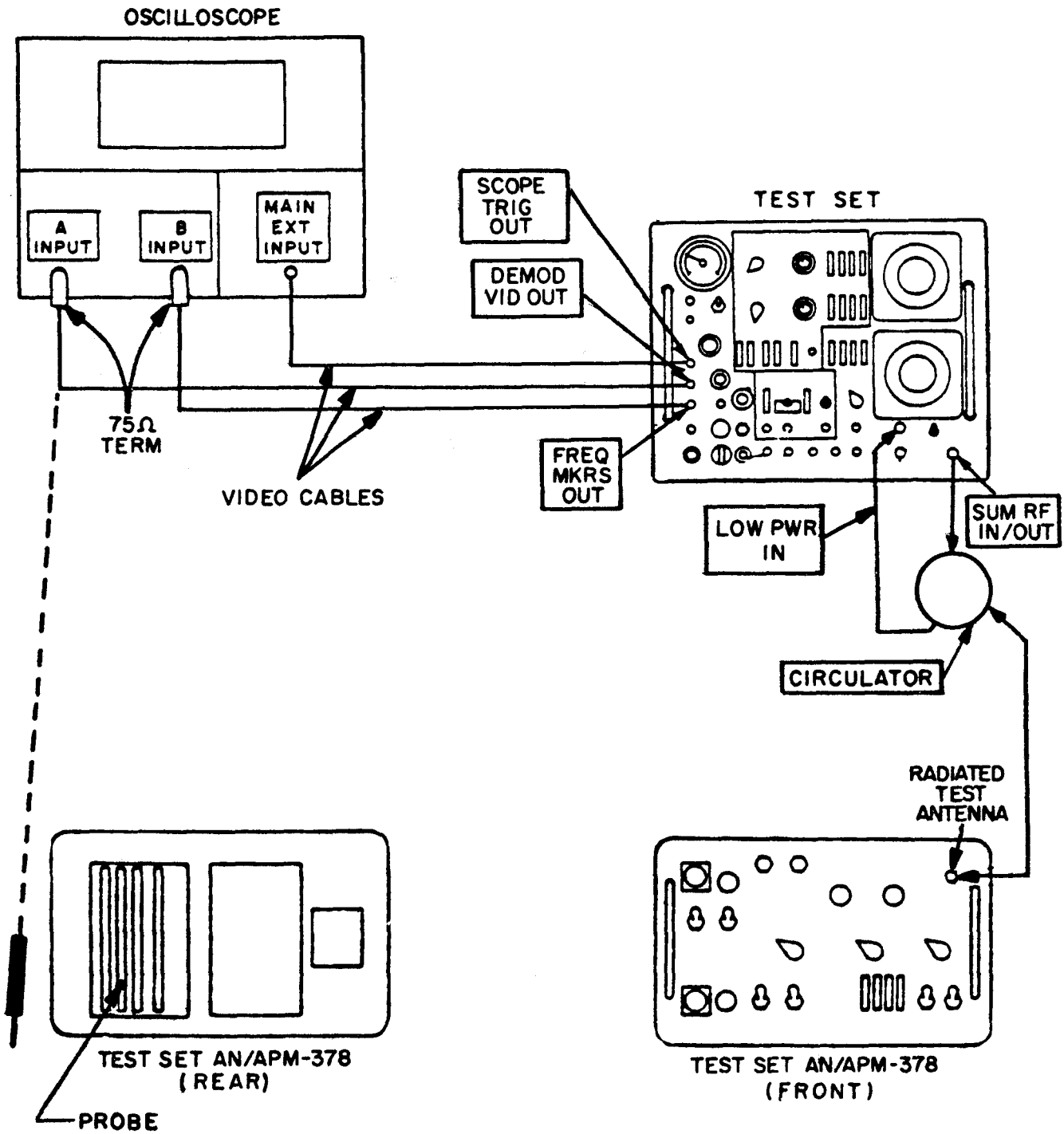

FIGURE 4-1. POWER SUPPLY CHECKS, TEST SETUP

EL2WZ001



EL2WZ002

FIGURE 4-2. TYPICAL TEST SETUP CONNECTIONS

Table 4-3. Transponder Set Test Set AN/APM-378, AN/TPM-25 Procedures

PROCEDURES	TEST EQUIPMENT CONTROL SETTINGS	CORRECT INDICATIONS/ MEASUREMENTS
(2) RECEIVER SENSITIVITY CHECKS		
<p>12. Connect test set and test equipment as shown in figure 4-2.</p> <p>13. Set AN/APM-378 controls as designated in steps 4 and 5 above. Set test equipment controls as noted.</p> <p>14. Check AN/TPM-25A PRF for 257 ± 5 pps.</p> <p>15. Adjust the AN/TPM-25 OUTPUT ATTENUATOR to obtain an ACCEPT/REJECT threshold indication on the AN/APM-378 (switchover point from REJECT to ACCEPT lamp lit).</p> <p>16. Attenuator reading plus Cable loss = Receiver Sensitivity</p>	<p>AN/TPM-25A Function SEL-PRF Cha1</p> <p>Oscilloscope: DISPLAY - CHAN A VERTICAL - VOLTS/DIV 1.0 HORIZONTAL - SYNC - INT CHAN A TIME/DIV- .5 ms</p>	<p>PRT 3907 ± 60 us</p> <p>257 ± 5 pps PRF reading.</p> <p>-6 ± 1 dBm. (If abnormal conditions are observed, perform receiver sensitivity adjustments (table 4-4). Leave rf module cover off until both receiver sensitivity and transmitter power adjustments are completed.) Attenuator Reading.</p>

Table 4-3. Transponder Set Test Set AN/APM-378, AN/TPM-25 Procedures

PROCEDURES	TEST EQUIPMENT CONTROL SETTINGS	CORRECT INDICATIONS/ MEASUREMENTS
(3) RECIEVER FREQUENCY AND BANDWIDTH CHECKS		
<p>17. Connect test set and test equipment as shown in figure 4-2. Connect test probe to U3TP10 (reply sample).</p> <p>18. Set AN/APM-378 controls as designated in steps 4 and 5 above. Set test equipment controls as noted. (Turn SYSTEM switch to LOBING).</p> <p>19. Change FREQ MEASURE control to center reply sample pulse over center frequency marker.</p> <p>20. Move FREQ MEASURE control clockwise until REJECT light turns on, then back until ACCEPT light is on.</p>	<p>Oscilloscope: DISPLAY - ALT VERTICAL - VOLTS/DIV HORIZONTAL - SYNC - INT CHAN B TIME/DIV - 0.5 us SWEEP VERNIER - adjust for 1 MHz/DIV</p> <p>AN/TPM-25 SIG GEN FUNCTION \pm 15 MHz ATTENUATOR - increase output 3 dB from Step 16 Adjust FREQ MEASURE for ACCEPT light on APM-378.</p>	<p style="text-align: center;">Interpolate reading on Oscilloscope. Record reading. This is the upper freq limits.</p>

Table 4-3. Transponder Set Test Set AN/APM-378, AN/TPM-25 Procedures

PROCEDURES	TEST EQUIPMENT CONTROL SETTINGS	CORRECT INDICATIONS/ MEASUREMENTS																															
(3) RECEIVER FREQUENCY AND BANDWIDTH CHECKS CONT'D																																	
<p>21. Move FREQ MEASURE control counter clockwise until opposite threshold is located.</p> <p>22. Compute Center Freq.</p>		<p>Interpolate reading on Oscilloscope. Record reading. This is the lower frequency limit. Subtract lower frequency from upper frequency to obtain bandwidth. Bandwidth should be 7 ± 1 MHz.</p> <p>Add readings step 20 and 21 and divide by 2. Center freq. should be 1090 ± 0.5 MHz.</p>																															
(4) RECEIVER REFERENCE CODE, EMERGENCY AND I/P FUNCTION OPERATION																																	
<p>23. Reconnect the test set and test equipment as shown in figure 4-2, and set the AN/APM-378 controls as designated in steps 4 & 5.</p> <p>24. On the AN/APM-378, set the REFERENCE CODE push-buttons in turn to each of the positions indicated and observe correct REJECT or ACCEPT conditions.</p>	<p>Radar Test Set AN/TPM-25: As designated for steps 13 and 14 and with OUTPUT ATTEN adjusted to -3dBm.</p> <table border="0" style="margin-left: auto; margin-right: auto;"> <tr> <td style="text-align: center;">AN/APM-378</td> <td style="text-align: center;">AN/TPM-25</td> </tr> <tr> <td style="text-align: center;">REF CODE</td> <td></td> </tr> <tr> <td style="text-align: center;">7700</td> <td style="text-align: center;">1111</td> </tr> <tr> <td style="text-align: center;">1111</td> <td style="text-align: center;">1111</td> </tr> <tr> <td style="text-align: center;">1111</td> <td style="text-align: center;">2222</td> </tr> <tr> <td style="text-align: center;">2222</td> <td style="text-align: center;">2222</td> </tr> <tr> <td style="text-align: center;">-</td> <td style="text-align: center;">-</td> </tr> <tr> <td style="text-align: center;">-</td> <td style="text-align: center;">-</td> </tr> <tr> <td style="text-align: center;">-</td> <td style="text-align: center;">-</td> </tr> <tr> <td style="text-align: center;">6666</td> <td style="text-align: center;">7777</td> </tr> <tr> <td style="text-align: center;">7777</td> <td style="text-align: center;">7777</td> </tr> </table>	AN/APM-378	AN/TPM-25	REF CODE		7700	1111	1111	1111	1111	2222	2222	2222	-	-	-	-	-	-	6666	7777	7777	7777	<table border="0" style="margin-left: auto; margin-right: auto;"> <tr> <td style="text-align: center;">REJECT</td> </tr> <tr> <td style="text-align: center;">ACCEPT</td> </tr> <tr> <td style="text-align: center;">REJECT</td> </tr> <tr> <td style="text-align: center;">ACCEPT</td> </tr> <tr> <td style="text-align: center;">-</td> </tr> <tr> <td style="text-align: center;">-</td> </tr> <tr> <td style="text-align: center;">-</td> </tr> <tr> <td style="text-align: center;">REJECT</td> </tr> <tr> <td style="text-align: center;">ACCEPT</td> </tr> </table>	REJECT	ACCEPT	REJECT	ACCEPT	-	-	-	REJECT	ACCEPT
AN/APM-378	AN/TPM-25																																
REF CODE																																	
7700	1111																																
1111	1111																																
1111	2222																																
2222	2222																																
-	-																																
-	-																																
-	-																																
6666	7777																																
7777	7777																																
REJECT																																	
ACCEPT																																	
REJECT																																	
ACCEPT																																	
-																																	
-																																	
-																																	
REJECT																																	
ACCEPT																																	

Change 1 4-9

TM 11-4920-296-148P

Table 4-3. Transponder Set Test Set AN/APM-378, AN/TPM-25 Procedures

PROCEDURES	TEST EQUIPMENT CONTROL SETTINGS		CORRECT INDICATIONS/ MEASUREMENTS		
(4) RECEIVER REFERENCE CODE, EMERGENCY AND I/P FUNCTION OPERATION CONT'D.					
25. Set the AN/APM-378 FUNCTION switch and MODE switch to the positions indicated, and observe correct ACCEPT or REJECT indications.	AN/APM-378		AN/TPM-25		
	<u>FUNCTION</u>	<u>MODE</u>			
	EMER	1	7700	EMER	ACCEPT
	EMER	2	7700	EMER	ACCEPT
	EMER	3/A	7700	EMER	ACCEPT
	EMER	C	7700	EMER	REJECT
	EMER	1	7700	SIF	REJECT
	EMER	2	7700	SIF	REJECT
	EMER	3/A	7700	SIF	REJECT
	EMER	C	7700	SIF	ACCEPT
	I/P	1	7777	I/P ML	REJECT (orNA)
	I/P	2	7777	I/P 2/3	ACCEPT
	I/P	3/A	7777	I/P 2/3	ACCEPT
	I/P	C	7777	I/P 2/3	REJECT
	I/P	1	7777	SIF	REJECT
	I/P	2	7777	SIF	REJECT
	I/P	3/A	7777	SIF	REJECT
I/P	C	7777	SIF	ACCEPT	

Table 4-3. Transponder Set Test Set AN/APM-378, AN/TPM-25 Procedures

PROCEDURES	TEST EQUIPMENT CONTROL SETTINGS	CORRECT INDICATIONS/ MEASUREMENTS
(5) TRANSMITTER POWER CHECKS		
<p>26. Connect the test set, and the test equipment as shown in figure 4-2. Set the AN/APM-378 controls as designated in steps 4 and 5 above. Set test equipment controls as noted.</p> <p>27. Set the AN/TPM-25 measurement DEMOD VID control for 1.0 volt of P1 or P3 on Oscilloscope channel "A"</p> <p>28. Adjust horizontal position placing P2 on center vertical graticule line.</p>	<p>Oscilloscope: DISPLAY - CHAN A VERTICAL - VOLTS/DIV 0.5 HORIZONTAL - SYNC INT TIME/DIV - 1.0 μ sec</p> <p>PWR(dBm) = METER READING + CABLE LOSS - 30. (see Power Measurement Chart)</p>	<p>Peak pulse power -6 ± 1 dBm (If abnormal conditions are noted, perform transmitter power adjustment of table 4-4, then reinstall rf module into test set.)</p> <p>-12 ± 3 dB from P1 pulse power.</p> <p>P2 Voltage 0.25 V - 12 dB 0.35 V - 9 dB 0.18 V - 15 dB</p>

Table 4-3. Transponder Set Test Set An/APM-378, AN/TPM-25 Procedures

4-12 Change 1

TM 11-4920-296-148P

PROCEDURES	TEST EQUIPMENT CONTROL SETTINGS	CORRECT INDICATIONS/ MEASUREMENTS
(6) TRANSMITTER FREQUENCY CHECKS		
<p>29. Connect test set and test equipment as shown in figure 4-2. Set AN/APM-378 controls as designated in steps 4 and 5 above; set test equipment controls as noted.</p> <p>30. Adjust MEASUREMENT FREQ MEAS control to peak signal on chan. A</p>	<p>Oscilloscope DISPLAY - ALT VERTICAL - VOLTS/DIV 5.0 HORIZONTAL - SYNC - INT CHAN B TIME / 0.5 us SWEEP VERNIER - adjust for 1 MHz/DIV</p> <p>TPM-25 SIG GEN FUNCTION + 5 MHz MEASUREMENT FUNCTION SEL - FREQ. Measure DEMOD VID level control - fully counter clockwise.</p>	<p>Interpolate Trans FREQ. 1030_± 0.2 MHZ.</p>
(7) TRANSMITTER PULSE CHECKS		
<p>31. Connect test set and test equipment as shown in figure 4-2.</p> <p>32. Set AN/APM-378 controls as designated in steps 4 and 5 above, except for the following:</p>		

Table 4-3. Transponder Set Test Set AN/APM-378, AN/TPM-25 Procedures

PROCEDURES	TEST EQUIPMENT CONTROL SETTINGS	CORRECT INDICATIONS/ MEASUREMENTS
(7) TRANSMITTER PULSE CHECKS CONT'D.		
<p>32. Cont'd. AN/APM-378 controls: MODE: As specified in following steps. CODE: Any positions. Set test equipment controls as noted:</p> <p>33. Place the AN/APM-378 MODE switch in each SIF mode and observe presence of complete interrogation pulse trains. (Move the CH A trace out of the way.)</p>	<p>Oscilloscope: HORIZONTAL DISPLAY - ALT TIME BASE A TRIGGER MODE - DC TIME BASE A TRIGGER SLOPE - INT TIME BASE A STABILITY AND TRIGGERING LEVEL - as required VARIABLE VOLTS/DIV - CHAN A - 0.1 CHAN B - 0.02</p> <p>Oscilloscope: HORIZONTAL SWEEP TIME - As required to display each mode set of pulses.</p>	

Table 4-3. Transponder Set Test Set AN/APM-378, AN/TPM-25 Procedures

PROCEDURES	TEST EQUIPMENT CONTROL SETTINGS	CORRECT INDICATIONS/ MEASUREMENTS
(7) TRANSMITTER PULSE CHECKS CONT'D.		
<p>34. Return AN/APM-378 MODE switch to MODE 1. Move CH2 trace to position 50% amplitude points on the center horizontal graticule line and measure the pulse width (between leading and trailing edge 50% amplitude points) of the P1 and P3 pulses.</p> <p>35. Activate the AN/APM-378 SLS switch by holding it in the MOM position. Measure the P2 pulse width at the 50% points.</p> <p>36. With the SLS switch activated, measure the leading edge spacing between the P1 and P2 pulses.</p> <p>37. Set the AN/APM-378 MODE switch to MODE 2. Determine the P1 to P3 spacing.</p> <p>38. Set the AN/APM-378 MODE switch to MODE 3/A. Determine the P1 to P3 spacing.</p>	<p>Oscilloscope: HORIZONTAL SWEEP TIME - 0.5 μs/cm</p>	<p>P1 and P3 pulse widths are $0.8 \pm 0.1 \mu$s.</p> <p>P2 pulse width is $0.8 \pm 0.1 \mu$s</p> <p>P1 to P2 pulse spacing is $2.0 \pm 0.15 \mu$s.</p> <p>MODE 2 P1 to P3 pulse interval is $5 \pm 0.2 \mu$s.</p> <p>MODE 3/A P1 to P3 pulse interval is $8 \pm 0.2 \mu$s.</p>

Table 4-3. Transponder Set Test Set AN/APM-378, AN/TPM-25 Procedures

PROCEDURES	TEST EQUIPMENT CONTROL SETTINGS	CORRECT INDICATIONS/ MEASUREMENTS
(7) TRANSMITTER PULSE CHECKS CONT'D		
<p>39. Use the same techniques as in step 38 to determine the P1 to P3 spacing for MODES C and TEST.</p>		<p>MODE TEST P1 to P3 pulse interval is $6.5 \pm 0.2 \mu\text{s}$. MODE C P1 to P3 pulse interval is $21.0 \pm 0.2 \mu\text{s}$.</p>
(8) MODE 4 PRETRIGGER		
<p>40. Connect the test set and the test equipments as shown in figure 4-3.</p> <p>41. Set the AN/APM-378 controls as follows: FUNCTION switch to SYSTEM SYSTEM TYPE switch to SINGLE CHANNEL MODE switch to 4 POWER switch to ON TEST switch to ON</p> <p>42. Observe the Mode 4 pretrigger and measure amplitude and pulse width.</p>	<p>Attach the special Mode 4 connector (figure 4-5) to J1 on the AN/APM-378 Test Set for all Mode 4 calibrations (7), (8), (9), and (10).</p> <p>Oscilloscope: DISPLAY - CHAN A VERTICAL - VOLTS/DIV 0.5 HORIZONTAL - SYNC - EXT TIME/DIV - $1.0 \mu\text{s}$.</p>	<p>Pretrigger Pulse - Amplitude: 1.5 V min into 91Ω Pulse Width: $1.0 \mu\text{s}$ to $2.0 \mu\text{s}$.</p>

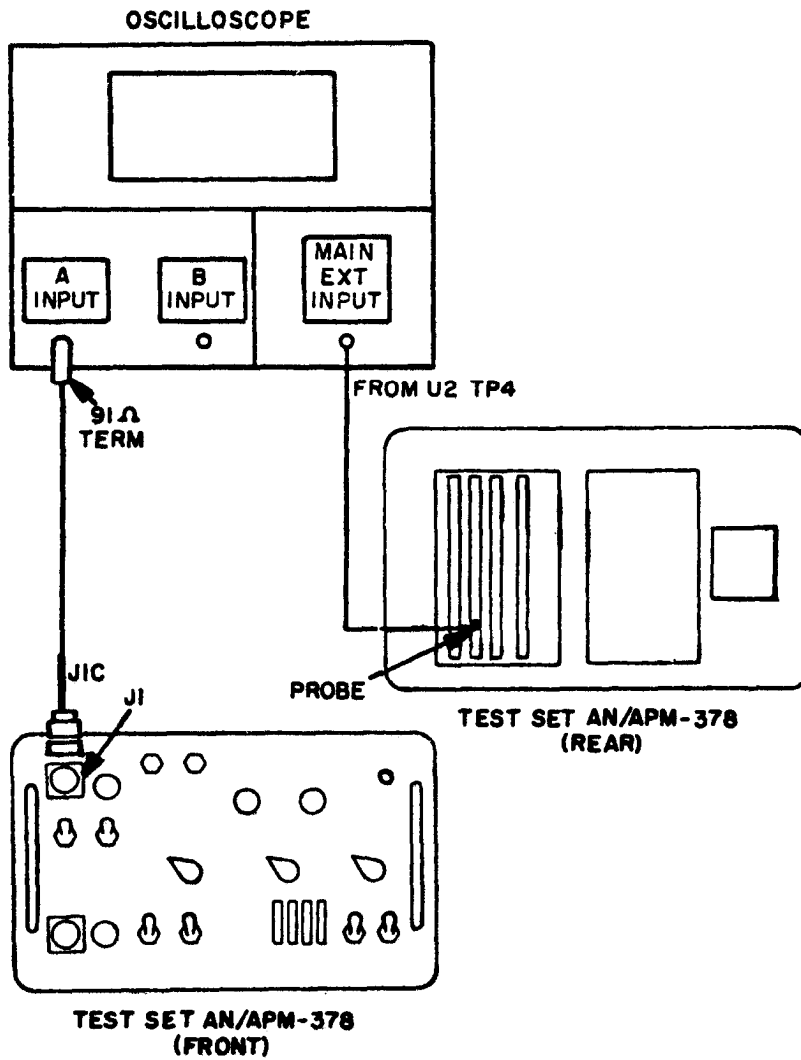

EL2WZ003

FIGURE 4-3. MODE 4 PRETRIGGER CHECK, TEST SETUP

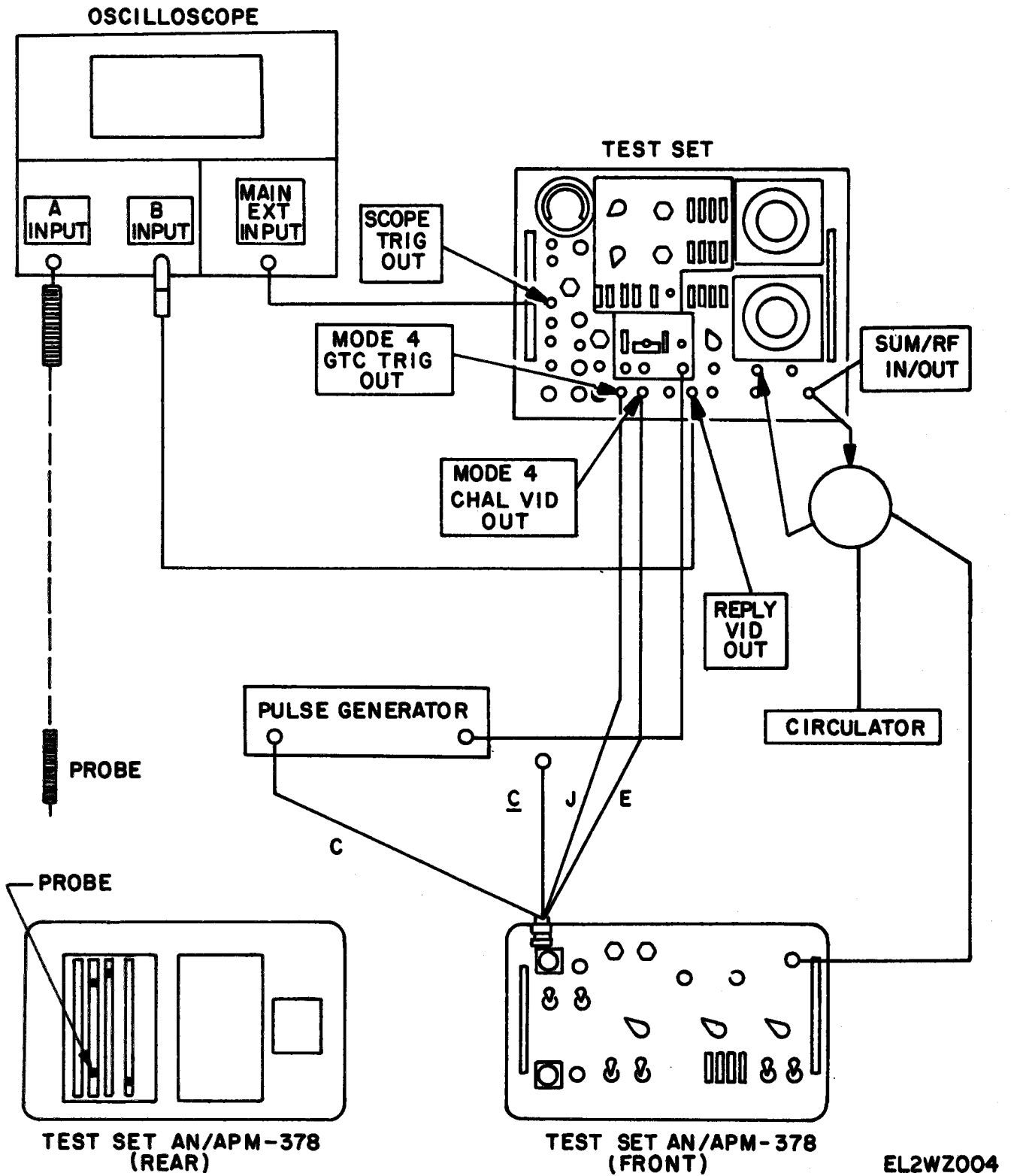

FIGURE 4-4. MODE 4 TYPICAL TEST SETUP CONNECTIONS

EL2WZ004

Table 4-3. Transponder Set Test Set AN/APM-378, AN/TPM-25 Procedures

4-18 CHANGE 1

TM 11-4920-296-148P

PROCEDURES	TEST EQUIPMENT CONTROL SETTINGS	CORRECT INDICATIONS/ MEASUREMENTS
(9) MODE 4 INTERROGATION VIDEO		
<p>43. Connect the test set equipment as shown in figure 4-4.</p> <p>44. Set the AN/APM-378 controls as designated in steps 41.</p> <p>45. Measure pulse amplitude from pulse generator on Oscilloscope and adjust for 5 volts. Then connect to EXT TRIG in Jack on-the AN/TPM-25A.</p> <p>46. Measure Pulses at U2TP8.</p>	<p>Oscilloscope: DISPLAY - CHAN A VERTICAL - VOLTS/DIV 2.0 HORIZONTAL - SYNC - EXT DELAY FUNCTION to EXPAND SIGNAL TPM-25A DCD Mode SEL-4 TRIG SEL-4</p>	<p>+5 v minimum</p> <p>37 pulses, No. 5 missing 3.5v 0.5 us.</p>
(10) MODE 4 SLS PULSE CHECKS		
<p>47. Connect the test equipment as shown in fig. 4-4.</p> <p>48. Remove CV cable from CHAL VID OUTPUT</p>		

Table 4-3. Transponder Set Test Set AN/APM-378, AN/TPM-25 Procedures

PROCEDURES	TEST EQUIPMENT CONTROL SETTINGS	CORRECT INDICATIONS/ MEASUREMENTS
<p>49. Connect SL Cable to CHAL VID OUTPUT.</p> <p>50. Observe that there is now one pulse from U2TP8 (CHAN A).</p> <p>51. Observe the side lobe gate pulse from U4TP1 (CHAN B) Position the base lines of the two channels to coincide.</p>	<p>Oscilloscope: DISPLAY - ALT VERTICAL - VOLTS/DIV 2.0 HORIZONTAL - SYNC - EXT, MAIN SWEEP - .05 ms, DELAY - 1 μs.</p>	<p>Levels are TTL Pulse width = 0.3 - 0.6 us levels of the side lobe gate are T+L.</p> <p>Observe that this pulse brackets the pulse shown on CHAN A.</p>
<p>(II) MODE 4 SYSTEM ACCEPT/REJECT CHECK</p>		
<p>52. Connect the test set and test equipment as shown in figure 4-4.</p> <p>53. Set the AN/APM-378 controls as designated in step 41.</p>	<p>Oscilloscope: DISPLAY - ALT VERTICAL - VOLTS/DIV 2.0 HORIZONTAL - SYNC - EXT TIME/DIV as required</p>	

Table 4-3. Transponder Set Test Set AN/APM-378, AN/TPM-25 Procedures

PROCEDURES	TEST EQUIPMENT CONTROL SETTINGS	CORRECT INDICATIONS/ MEASUREMENTS
<p>54. Adjust AN/TPM-25 OUTPUT ATTENUATOR to odBm. Modulation Select-M4-3P DCD MODE SEL-4 Trig Sel-Ext.</p> <p>55. Connect CHAN A to U3TP9 of the Test Set, using a 10X probe.</p> <p>56. Measure GTE Gate width Note three-ulse reply on CHANNEL B.</p> <p>57. On AN/TPM-25A, using RANGE DELAY switch, shift three-pulse reply from GTE gate.</p>		<p>Observe an ACCEPT condition on the AN/APM-378.</p> <p>Observe the GTC gate from U3TP9 on CHAN A.</p> <p>GTC gate width 71 +15 us -0</p> <p>Observe a REJECT condition on the AN/APM-378.</p>

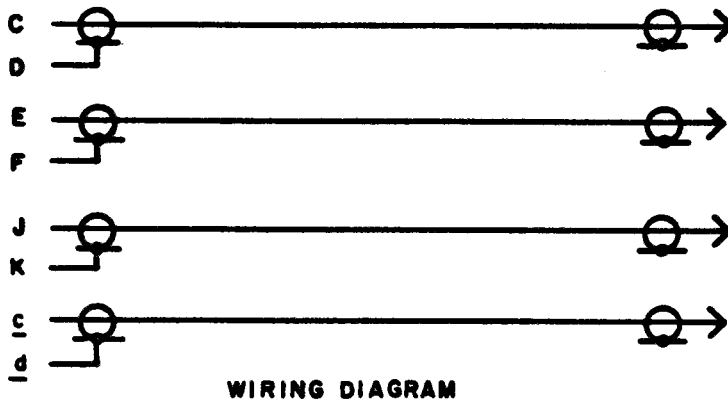
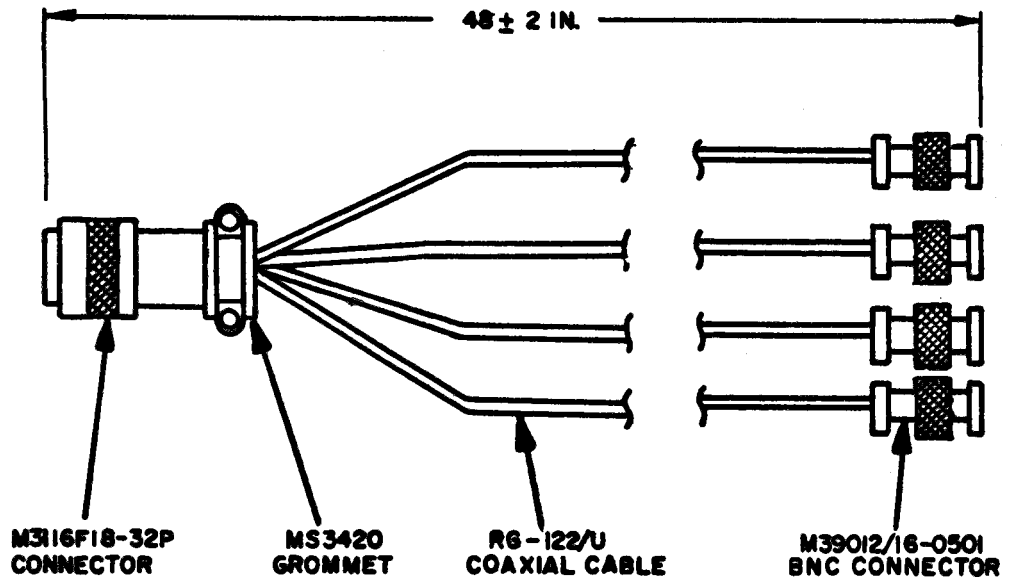

EL2WZ005

FIGURE 4-5. SPECIAL MODE 4 CALIBRATION CONNECTOR

Table 4-4. Transponder Set Test Set AN/APM-378 Adjustments

PROCEDURES	TEST EQUIPMENT CONTROL SETTINGS	ADJUSTMENT PARAMETER
PRELIMINARY SETUP		
<ol style="list-style-type: none"> 1. Remove the test set front panel and chassis assembly from the case. 2. For access to the adjustment controls, remove the housing from the rf module A1 as follows: <ol style="list-style-type: none"> a. Disconnect the 3 rf cables from the side of the rf module A1. b. Release the 2 hold-downs at the opposite corners of the module housing, and gently lift the A1 module out of its plug-in connector on the chassis assembly. c. Remove the 10 screws (6 at top, 2 on each side) and carefully remove the housing. Place module into its chassis assembly connector, and reconnect the 3 rf cables (cables are marked, and the housing markings identify the jacks). <p style="text-align: center;">----- CAUTION -----</p> <p>When making the adjustments, and in positioning the test set for access to front panel or chassis points, use care to prevent drop-out of the unhoused rf module A1 from its chassis plug-in connector.</p>		

Table 4-4. Transponder Set Test Set AN/APM-378 Adjustments

PROCEDURES	TEST EQUIPMENT CONTROL SETTINGS	ADJUSTMENT PARAMETER
RECEIVER SENSITIVITY ADJUSTMENT		
<p>3. Refer to table 4-3 and perform steps 12 thru 16.</p> <p>4. Adjust the Radar Test Set AN/TPM-25A OUTPUT ATTENUATOR as noted, and adjust A1R1 of the rf module A1 to obtain an ACCEPT/REJECT threshold indication on the AN/APM-378 (switchover point from REJECT to ACCEPT lit).</p>		<p>ACCEPT/REJECT threshold is obtained on AN/APM-378, by adjustment of A1R1.</p>
TRANSMITTER POWER ADJUSTMENT		
<p>5. Refer to table 4-3 and perform steps 26 thru 28.</p> <p>6. Adjust potentiometer A1R2 of the rf module, until power meter indicates -6 ± 1 dBm in step 28 of table 4-2.</p>		<p>Power indication of -6 ± 1 dBm is obtained by adjustment of A1R2.</p>

Change 1
4-23/(4-24 Blank)

SECTION 5

PRESERVATION, PACKAGING, AND PREPARATION FOR USE

5-1. GENERAL.

5-2. This section contains information on special requirements for storage, packaging of equipment for shipment or storage, and preparation for use.

5-3. PRESERVATION REQUIREMENTS.

5-4. No special procedures or considerations are necessary for preservation and storage of the equipment. Packaging for storage consists of placing a dessicant bag within the equipment case and then placing the equipment in a cardboard commercial Shipping box. Packing material should be

used around the equipment to prevent shifting within the shipping/storage container.

5-5. PREPARATION FOR USE.

5-6. As shipped from the manufacturer, the equipment is contained in a commercial cardboard shipping box. Unpacking of the equipment consists of opening the box, removing shipping packing, and removing the test set. After opening the test set case cover, remove the dessicant. Operate the pressure equalization valve on the test set case, to equalize the internal case pressure to that at the locality where the equipment is to be used.

SECTION 6 ILLUSTRATED PARTS BREAKDOWN

SECTION I INTRODUCTION

6-1. **SCOPE**.

6-2. This section lists, describes, and illustrates assemblies, subassemblies, and detail parts for Transponder Set Test Set AN/APM-378.

6-3. **PURPOSE AND USE**.

6-4. The purpose of this Illustrated Parts Breakdown (IPB) is to provide a list of items necessary for the support of the test set. This section is for use in requisitioning, storing, issuing, and identifying parts and consists of the following sections:

- Section I - Introduction
- Section II - Group Assembly Parts List
- Section III - Numerical Index
- Section IV - Reference Designation Index

6-5. **SECTION I. INTRODUCTION**.

6-6. The introduction consists of general instructions for the use of this Illustrated Parts Breakdown, definitions of the usable on codes, and a complete list of vendors supplying items not carried under the prime contractor's part number, together with associated Federal Supply Codes. A list of applicable change directives (the parts information of which has been incorporated into this IPB) is listed in Section 1 of this manual.

6-7. **SECTION II. GROUP ASSEMBLY PARTS LIST**.

6-8. **GENERAL.** The Group Assembly Parts List (GAPL) is an illustrated

breakdown of the test set in disassembly sequence. The parts list includes the part numbers, descriptions, manufacturer's Federal Supply Codes, units per assembly, and usable on codes. Explanations of columnar data provided in the GAPL are presented in the following paragraphs.

6-9. **Figure and Index Number.** This column contains the numerically arranged figure numbers for each illustration. Within each figure, numerically arranged index numbers are assigned to aid in locating a part in the GAPL and the associated illustrations.

6-10. **Part Number Column.** The numbers listed in the Part Number column are either the contractor's assigned numbers, Government standard numbers (AN, MS, etc.), or vendor part numbers.

6-11. **Description Column.** Descriptions include appropriate nomenclature to define the items. Entries are numerically indented to indicate assembly relationships: the next higher assembly (NHA) for each listed item may be obtained by referring to the first indenture above and to the left. The parenthetical designation code (AP) following the description of a part, indicates that the specific part is used to attach the items immediately preceding the designated part in the GAPL.

6-12. **Units Per Assembly Column.** The quantities listed in this column are only the quantities used on one next higher assembly at the location indicated. These quantities are not necessarily the total used per test set.

6-13. **Usable on Code Column.** Variations within assemblies and subassemblies of the

test set are indicated by letter codes in the Usable on Code column. The absence of a code in this column indicates that the parts are usable on all articles covered by this publication.

6-14. Vendor's Code. The vendor is identified by either a Federal Code Number as designated in Cataloging Handbook (H4-1) and Federal Supply Code for Manufacturers (H4-2) listed in the description column or by three alphabetic characters. For a complete list of names and addresses of all vendors supplying items not carried under the prime contractor's part number, together with associated Federal Supply Codes, refer to the List of Manufacturers located at the end of this section.

6-15. SECTION III, NUMERICAL INDEX.

6-16. GENERAL. The Numerical Index provides part numbers, GA JPL figures and index numbers and source codes. Explanations of the columnar data included in the numerical index are covered in the following paragraphs.

6-17. Part Number Column. All part numbers that appear in the GAPL are arranged in alpha-numerical sequence in this column. The alpha-numerical part number sequencing is based on the precedence outlined below.

1. Alpha-numerical part number arrangement begins on the extreme left-hand position and continues from left to right, one position at a time, until all parts are arranged in sequence.

2. The order of precedence in beginning the part number arrangement on the extreme left-hand (first) position of the part number is as follows:

- a. Letters A through Z.
- b. Numerals 0 through 9.

3. The order of precedence in continuing the part number arrangement in second and succeeding positions is as follows:

- a. Space (blank column).
- b. Diagonal (slant) /.
- c. Point (period).
- d. Dash (-).
- e. Letters A through Z.
- f. Numerals 0 through 9. (The alphabetical O's are considered numerical zeros.)

6-18. FIGURE AND INDEX NUMBER COLUMN. This column lists the figure and index numbers of which are used to locate parts in the GAPL. When an item is not assigned an index number, only the figure number appears.

6-19. CODES COLUMN. Definitions and explanations of Source, Maintenance, Recoverability (SM&R)/Accountability, Kit Codes and Repair Codes used in the Numerical Index of this section are contained in NAVAIR 4423. 3A.

6-20. SECTION IV. REFERENCE DESIGNATION INDEX.

6-21. The Reference Designation Index consists of those electrical and electronic parts to which reference may be made in schematics, with applicable figure and index number and part number for each reference designation.

6-22. Reference Designation (REF DES). This column consists of alphabetically and numerically arranged designations which have been assigned to electrical and electronic parts.

6-23. Figure Index Number. This column contains the figure and index number for each reference designated item listed.

6-24. Part Number. This column contains the part number for each reference designated item listed.

6-25. ABBREVIATIONS.

6-26. The abbreviations used throughout this publication are in accordance with MIL-STD-12C.

6-27. HOW TO USE THE ILLUSTRATED PARTS BREAKDOWN.

6-28. Information on how to use the Illustrated Parts Breakdown is contained at the end of the Introduction.

6-29. VENDOR CODES.

6-30. Provided below is a list of Federal manufacturer's codes, names and addresses

of vendors who supplied items not carried under the prime contractor's part numbers. The absence of a code or contractor's name and address following a part description in Section II shall mean that the item is either a prime contractor's part or an AN or MS item. The list is arranged in numerical sequence of Federal manufacturer's codes.

LIST OF MANUFACTURERS

CODE	MFR'S NAME AND ADDRESS
04713	Motorola, Inc. Semiconductor Products Div 5005 E. McDowell Rd. Phoenix, AZ 85008
06540	Amatom Electronic Hardware Div Mite Corp. 446 Blake St. New Haven, CT 06515
06845	The Bendix Corp. Communications Div E. Joppa Rd. Baltimore, MD 21204
07263	Fairchild Semiconductor, A Div of Fairchild Camera and Instrument Corp. 464 Ellis St. Mountain View, CA 94040
07886	National Radio Co. , Inc. Commercial Products Div 78 Stone Pl Melrose, MA 02176
08795	Rayclad Tubes, Inc. 300 Constitution Drive Menlo Park, CA 94025
08806	General Electric Co. Miniature Lamp Products Dept. Nela Pk Cleveland, OH 44112
12294	Erie Technological Products of Canada Ltd Trenton, Ontario, Canada

CODE	MFR'S NAME AND ADDRESS
12615	US Terminals, Inc. 7504 Camargo Rd. Cincinnati, OH 45243
16512	Fabri-Tek, Inc. National Connector Div 9210 Science Center Dr New Hope, MN 55428
17117	Electronic Molding Corp. 96 Mill St. Woonsocket, RI 02895
18565	Chomerics 77 Dragon Ct Woburn, MA 01801
18677	Scanbe Mfg Corp. 3445 Fletcher Ave. El Monte, CA 91731
19178	Zero Mfg Co., East Division 280 Main St. Monson, MA 01057
42498	National Radio Co. , Inc. 78 Stone Pl Melrose, MA 02176
72962	Elastic Stop Nut Div of Amerace Esna Corp. 2330 Vauxhall Rd. Union, NJ 07083
74868	Bunker Ramo Corp. Amphenol RF Div 33 E. Franklin St. Danbury, CT 06810
77820	The Bendix Corp. Electrical Components Div Sherman Ave. Sidney, NY 13838

LIST OF MANUFACTURERS (Cont)

CODE	MFR'S NAME AND ADDRESS
80205	National Aerospace Standards Committee Aerospace Industries Asso. of America, Inc. 1725 DeSales, N.W. Washington, DC 20036
80223	TRW Electronic Components United Transformer Div 150 Varick St. New York, NY 10013
81349	Military Specifications
82152	Transco Products, Inc. 4241 Glenco Ave. Venice, CA 90292
87034	Marco Oak Industries, Inc. P. O. Box 4011 207 S. Helena Anaheim, CA 92803
88044	Aeronautical Standards Group Dept. of Navy and Air Force

CODE	MFR'S NAME AND ADDRESS
91812	Janco Corp. 3111 Winona Ave. Box 3038 Burbank, CA 91504
95712	The Bendix Corp. Electrical Components Div Microwave Devices Plant Hurricane Rd. Franklin, IN 46131
96906	Military Standards
98291	Seaelectro Corp. 225 Hoyt Mamaroneck, NY 10544
99378	Atlee Corp. 2 Lowell Ave. Winchester, MA 01890
ESF	Electro-Space Fabricators, Inc. Center Ave. Topton, PA 19562

HOW TO USE THE ILLUSTRATED PARTS BREAKDOWN

NAVAIR 16-36APX12-3/NAVSHIPS 0907-217-4030/
T.O. 12P4-2APX12-4

TABLE OF CONTENTS

Section	Page Number	Section	Page Number
I INTRODUCTION	1-1	Sensitivity	2-35
II GROUP ASSEMBLY PARTS LIST	2-1	Amplifier Video Board No. 2	2-36
Receiver-Transmitter Radio RT-659/APX-72	2-1	Amplifier Video Board No. 1	2-40
Mounting RT-659/APX-72 and Mounting APX-72	2-1	Control Oscillator Module	2-42
Mount Mt-3009/APX-72	2-2	Module Assembly	2-44
Mount Mt-3048/APX-72	2-4	1 KV Assembly	2-46
Receiver-Transmitter (Sheet 1 of 3) RT-659/APX-72	2-6	Output Assembly	2-47
Receiver-Transmitter (Sheet 2 of 3) RT-659/APX-72	2-7	Inverter Drive Transistors	2-50
R. F. Section Assembly	2-11	Subassembly Interconnection Board and Cable Assembly	2-51
Processor	2-14	Over Current Assembly	2-52
Mode 4	2-17	Switching Regulator	2-53
Encoder Gating	2-18	Filter Capacitor Assembly	2-55
Power Supply Assembly (Sheet 1 of 2)	2-19	Connector and Filter Assembly	2-57
Power Supply Assembly (Sheet 2 of 2)	2-20	Front Panel Assembly	2-59
Decoder	2-23	List of Extender Boards	2-61
Encoder Check	2-28	III NUMERICAL INDEX (NAVALY)	2-1
Receiver-Transmitter Subassembly	2-31	NUMERICAL INDEX (ADR FORCE)	2-6
Detector and Video Amplifier	2-32		

NAVAIR 16-36APX12-3/NAVSHIPS 0907-217-4030/
T.O. 12P4-2APX12-4

Section II
Group Assembly Parts List

NAVAIR 16-36APX12-3/NAVSHIPS 0907-217-4030/
T.O. 12P4-2APX12-4

Section II
Group Assembly Parts List

FIG. OR DRAWING NO.	PART NO.	DESCRIPTION	UNITS PER SET	ENABLE OR CODE
1	082300-001	RECEIVER-TRANSMITTER RT-659/APX-72 (see Fig. 1 for details)	1	DET
2	082301-001	RF SECTION ASSEMBLY (see Fig. 2 for details)	1	
3	082302-001	PROCESSOR	1	
4	082303-001	PLATE ASSEMBLY	1	
5	082304-001	CONTROL OSCILLATOR MODULE	1	
6	082305-001	MODULE ASSEMBLY (see Fig. 3 for details)	1	
7	082306-001	1 KV ASSEMBLY	1	
8	082307-001	OUTPUT ASSEMBLY (see Fig. 4 for details)	1	
9	082308-001	INVERTER DRIVE TRANSISTORS	1	
10	082309-001	INTERCONNECTION BOARD AND CABLE ASSEMBLY	1	
11	082310-001	OVER CURRENT ASSEMBLY	1	
12	082311-001	SWITCHING REGULATOR	1	
13	082312-001	FILTER CAPACITOR ASSEMBLY	1	
14	082313-001	CONNECTOR AND FILTER ASSEMBLY	1	
15	082314-001	FRONT PANEL ASSEMBLY	1	
16	082315-001	LIST OF EXTENDER BOARDS	1	
17	082316-001	RECEIVER-TRANSMITTER RT-659/APX-72 (see Fig. 12 for details)	1	
18	082317-001	RECEIVER-TRANSMITTER RT-659/APX-72 (see Fig. 13 for details)	1	
19	082318-001	RECEIVER-TRANSMITTER RT-659/APX-72 (see Fig. 14 for details)	1	
20	082319-001	RECEIVER-TRANSMITTER RT-659/APX-72 (see Fig. 15 for details)	1	
21	082320-001	RECEIVER-TRANSMITTER RT-659/APX-72 (see Fig. 16 for details)	1	
22	082321-001	RECEIVER-TRANSMITTER RT-659/APX-72 (see Fig. 17 for details)	1	
23	082322-001	RECEIVER-TRANSMITTER RT-659/APX-72 (see Fig. 18 for details)	1	
24	082323-001	RECEIVER-TRANSMITTER RT-659/APX-72 (see Fig. 19 for details)	1	
25	082324-001	RECEIVER-TRANSMITTER RT-659/APX-72 (see Fig. 20 for details)	1	
26	082325-001	RECEIVER-TRANSMITTER RT-659/APX-72 (see Fig. 21 for details)	1	
27	082326-001	RECEIVER-TRANSMITTER RT-659/APX-72 (see Fig. 22 for details)	1	
28	082327-001	RECEIVER-TRANSMITTER RT-659/APX-72 (see Fig. 23 for details)	1	
29	082328-001	RECEIVER-TRANSMITTER RT-659/APX-72 (see Fig. 24 for details)	1	
30	082329-001	RECEIVER-TRANSMITTER RT-659/APX-72 (see Fig. 25 for details)	1	
31	082330-001	RECEIVER-TRANSMITTER RT-659/APX-72 (see Fig. 26 for details)	1	
32	082331-001	RECEIVER-TRANSMITTER RT-659/APX-72 (see Fig. 27 for details)	1	
33	082332-001	RECEIVER-TRANSMITTER RT-659/APX-72 (see Fig. 28 for details)	1	

WHEN THE PART NUMBER IS NOT KNOWN

- Determine the function and application of the part required. Turn to the Table of Contents and select the most appropriate title. Note the illustration page number.
- Turn to the page indicated and locate the desired part on the illustration.
- From the illustration, obtain the index number assigned to the part desired. Refer to the accompanying description for specific information regarding the part.

HOW TO USE THE ILLUSTRATED PARTS BREAKDOWN

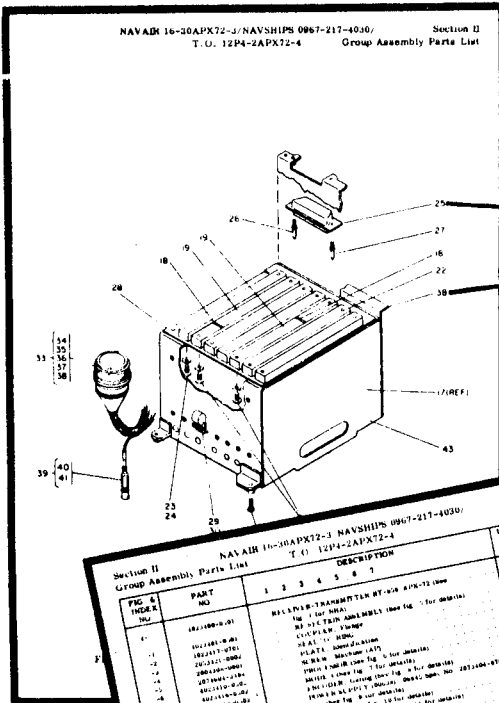

NAVADM 16-00APX72-3 NAVSHIPS 0967-217-4030 Section IV
T.O. 12P4-2APX72-4 Reference Designation Index

SECTION IV
REFERENCE DESIGNATION INDEX

REFERENCE DESIGNATION	FIG. & INDEX NO.	PART NO.	REFERENCE DESIGNATION	FIG. & INDEX NO.	PART NO.
AKM1	1-18	AKM1-18-001	AKM22	14-2	AKM22-14-001
AKM2	1-18	AKM2-18-001	AKM23	14-2	AKM23-14-001
AKM3	1-21	AKM3-21-001	AKM24	14-2	AKM24-14-001
AKM4	1-21	AKM4-21-001	AKM25	14-2	AKM25-14-001
AKM5	1-24	AKM5-24-001	AKM26	14-2	AKM26-14-001
AKM6	1-24	AKM6-24-001	AKM27	14-2	AKM27-14-001
AKM7	1-27	AKM7-27-001	AKM28	14-2	AKM28-14-001
AKM8	1-27	AKM8-27-001	AKM29	14-2	AKM29-14-001
AKM9	1-31	AKM9-31-001	AKM30	14-2	AKM30-14-001
AKM10	1-31	AKM10-31-001	AKM31	14-2	AKM31-14-001
AKM11	1-34	AKM11-34-001	AKM32	14-2	AKM32-14-001
AKM12	1-34	AKM12-34-001	AKM33	14-2	AKM33-14-001
AKM13	1-37	AKM13-37-001	AKM34	14-2	AKM34-14-001
AKM14	1-37	AKM14-37-001	AKM35	14-2	AKM35-14-001
AKM15	1-40	AKM15-40-001	AKM36	14-2	AKM36-14-001
AKM16	1-40	AKM16-40-001	AKM37	14-2	AKM37-14-001
AKM17	1-43	AKM17-43-001	AKM38	14-2	AKM38-14-001
AKM18	1-43	AKM18-43-001	AKM39	14-2	AKM39-14-001
AKM19	1-46	AKM19-46-001	AKM40	14-2	AKM40-14-001
AKM20	1-46	AKM20-46-001	AKM41	14-2	AKM41-14-001
AKM21	1-49	AKM21-49-001	AKM42	14-2	AKM42-14-001
AKM22	1-49	AKM22-49-001	AKM43	14-2	AKM43-14-001
AKM23	1-52	AKM23-52-001	AKM44	14-2	AKM44-14-001
AKM24	1-52	AKM24-52-001	AKM45	14-2	AKM45-14-001
AKM25	1-55	AKM25-55-001	AKM46	14-2	AKM46-14-001
AKM26	1-55	AKM26-55-001	AKM47	14-2	AKM47-14-001
AKM27	1-58	AKM27-58-001	AKM48	14-2	AKM48-14-001
AKM28	1-58	AKM28-58-001	AKM49	14-2	AKM49-14-001
AKM29	1-61	AKM29-61-001	AKM50	14-2	AKM50-14-001
AKM30	1-61	AKM30-61-001	AKM51	14-2	AKM51-14-001
AKM31	1-64	AKM31-64-001	AKM52	14-2	AKM52-14-001
AKM32	1-64	AKM32-64-001	AKM53	14-2	AKM53-14-001
AKM33	1-67	AKM33-67-001	AKM54	14-2	AKM54-14-001
AKM34	1-67	AKM34-67-001	AKM55	14-2	AKM55-14-001
AKM35	1-70	AKM35-70-001	AKM56	14-2	AKM56-14-001
AKM36	1-70	AKM36-70-001	AKM57	14-2	AKM57-14-001
AKM37	1-73	AKM37-73-001	AKM58	14-2	AKM58-14-001
AKM38	1-73	AKM38-73-001	AKM59	14-2	AKM59-14-001
AKM39	1-76	AKM39-76-001	AKM60	14-2	AKM60-14-001
AKM40	1-76	AKM40-76-001	AKM61	14-2	AKM61-14-001
AKM41	1-79	AKM41-79-001	AKM62	14-2	AKM62-14-001
AKM42	1-79	AKM42-79-001	AKM63	14-2	AKM63-14-001
AKM43	1-82	AKM43-82-001	AKM64	14-2	AKM64-14-001
AKM44	1-82	AKM44-82-001	AKM65	14-2	AKM65-14-001
AKM45	1-85	AKM45-85-001	AKM66	14-2	AKM66-14-001
AKM46	1-85	AKM46-85-001	AKM67	14-2	AKM67-14-001
AKM47	1-88	AKM47-88-001	AKM68	14-2	AKM68-14-001
AKM48	1-88	AKM48-88-001	AKM69	14-2	AKM69-14-001
AKM49	1-91	AKM49-91-001	AKM70	14-2	AKM70-14-001
AKM50	1-91	AKM50-91-001	AKM71	14-2	AKM71-14-001
AKM51	1-94	AKM51-94-001	AKM72	14-2	AKM72-14-001
AKM52	1-94	AKM52-94-001	AKM73	14-2	AKM73-14-001
AKM53	1-97	AKM53-97-001	AKM74	14-2	AKM74-14-001
AKM54	1-97	AKM54-97-001	AKM75	14-2	AKM75-14-001
AKM55	1-100	AKM55-100-001	AKM76	14-2	AKM76-14-001
AKM56	1-100	AKM56-100-001	AKM77	14-2	AKM77-14-001
AKM57	1-103	AKM57-103-001	AKM78	14-2	AKM78-14-001
AKM58	1-103	AKM58-103-001	AKM79	14-2	AKM79-14-001
AKM59	1-106	AKM59-106-001	AKM80	14-2	AKM80-14-001
AKM60	1-106	AKM60-106-001	AKM81	14-2	AKM81-14-001
AKM61	1-109	AKM61-109-001	AKM82	14-2	AKM82-14-001
AKM62	1-109	AKM62-109-001	AKM83	14-2	AKM83-14-001
AKM63	1-112	AKM63-112-001	AKM84	14-2	AKM84-14-001
AKM64	1-112	AKM64-112-001	AKM85	14-2	AKM85-14-001
AKM65	1-115	AKM65-115-001	AKM86	14-2	AKM86-14-001
AKM66	1-115	AKM66-115-001	AKM87	14-2	AKM87-14-001
AKM67	1-118	AKM67-118-001	AKM88	14-2	AKM88-14-001
AKM68	1-118	AKM68-118-001	AKM89	14-2	AKM89-14-001
AKM69	1-121	AKM69-121-001	AKM90	14-2	AKM90-14-001
AKM70	1-121	AKM70-121-001	AKM91	14-2	AKM91-14-001
AKM71	1-124	AKM71-124-001	AKM92	14-2	AKM92-14-001
AKM72	1-124	AKM72-124-001	AKM93	14-2	AKM93-14-001
AKM73	1-127	AKM73-127-001	AKM94	14-2	AKM94-14-001
AKM74	1-127	AKM74-127-001	AKM95	14-2	AKM95-14-001
AKM75	1-130	AKM75-130-001	AKM96	14-2	AKM96-14-001
AKM76	1-130	AKM76-130-001	AKM97	14-2	AKM97-14-001
AKM77	1-133	AKM77-133-001	AKM98	14-2	AKM98-14-001
AKM78	1-133	AKM78-133-001	AKM99	14-2	AKM99-14-001
AKM79	1-136	AKM79-136-001	AKM100	14-2	AKM100-14-001
AKM80	1-136	AKM80-136-001			

NAVADM 16-00APX72-3 NAVSHIPS 0967-217-4030 Section II
T.O. 12P4-2APX72-4 Group Assembly Parts List

SECTION II
GROUP ASSEMBLY PARTS LIST

FIG. & INDEX NO.	PART NO.	DESCRIPTION	QTY PER ASSEMBLY	UNITS PER ASSEMBLY	ENABLE ON CODE
1-1	100100-001	RECEPTOR TRANSMITTER RT-594A-11000	1	1	
1-2	100100-002	RECEPTOR TRANSMITTER RT-594A-11000	1	1	
1-3	100100-003	RECEPTOR TRANSMITTER RT-594A-11000	1	1	
1-4	100100-004	RECEPTOR TRANSMITTER RT-594A-11000	1	1	
1-5	100100-005	RECEPTOR TRANSMITTER RT-594A-11000	1	1	
1-6	100100-006	RECEPTOR TRANSMITTER RT-594A-11000	1	1	
1-7	100100-007	RECEPTOR TRANSMITTER RT-594A-11000	1	1	
1-8	100100-008	RECEPTOR TRANSMITTER RT-594A-11000	1	1	
1-9	100100-009	RECEPTOR TRANSMITTER RT-594A-11000	1	1	
1-10	100100-010	RECEPTOR TRANSMITTER RT-594A-11000	1	1	
1-11	100100-011	RECEPTOR TRANSMITTER RT-594A-11000	1	1	
1-12	100100-012	RECEPTOR TRANSMITTER RT-594A-11000	1	1	
1-13	100100-013	RECEPTOR TRANSMITTER RT-594A-11000	1	1	
1-14	100100-014	RECEPTOR TRANSMITTER RT-594A-11000	1	1	
1-15	100100-015	RECEPTOR TRANSMITTER RT-594A-11000	1	1	
1-16	100100-016	RECEPTOR TRANSMITTER RT-594A-11000	1	1	
1-17	100100-017	RECEPTOR TRANSMITTER RT-594A-11000	1	1	
1-18	100100-018	RECEPTOR TRANSMITTER RT-594A-11000	1	1	
1-19	100100-019	RECEPTOR TRANSMITTER RT-594A-11000	1	1	
1-20	100100-020	RECEPTOR TRANSMITTER RT-594A-11000	1	1	
1-21	100100-021	RECEPTOR TRANSMITTER RT-594A-11000	1	1	
1-22	100100-022	RECEPTOR TRANSMITTER RT-594A-11000	1	1	
1-23	100100-023	RECEPTOR TRANSMITTER RT-594A-11000	1	1	
1-24	100100-024	RECEPTOR TRANSMITTER RT-594A-11000	1	1	
1-25	100100-025	RECEPTOR TRANSMITTER RT-594A-11000	1	1	
1-26	100100-026	RECEPTOR TRANSMITTER RT-594A-11000	1	1	
1-27	100100-027	RECEPTOR TRANSMITTER RT-594A-11000	1	1	
1-28	100100-028	RECEPTOR TRANSMITTER RT-594A-11000	1	1	
1-29	100100-029	RECEPTOR TRANSMITTER RT-594A-11000	1	1	
1-30	100100-030	RECEPTOR TRANSMITTER RT-594A-11000	1	1	
1-31	100100-031	RECEPTOR TRANSMITTER RT-594A-11000	1	1	
1-32	100100-032	RECEPTOR TRANSMITTER RT-594A-11000	1	1	
1-33	100100-033	RECEPTOR TRANSMITTER RT-594A-11000	1	1	
1-34	100100-034	RECEPTOR TRANSMITTER RT-594A-11000	1	1	
1-35	100100-035	RECEPTOR TRANSMITTER RT-594A-11000	1	1	
1-36	100100-036	RECEPTOR TRANSMITTER RT-594A-11000	1	1	
1-37	100100-037	RECEPTOR TRANSMITTER RT-594A-11000	1	1	
1-38	100100-038	RECEPTOR TRANSMITTER RT-594A-11000	1	1	
1-39	100100-039	RECEPTOR TRANSMITTER RT-594A-11000	1	1	
1-40	100100-040	RECEPTOR TRANSMITTER RT-594A-11000	1	1	
1-41	100100-041	RECEPTOR TRANSMITTER RT-594A-11000	1	1	
1-42	100100-042	RECEPTOR TRANSMITTER RT-594A-11000	1	1	
1-43	100100-043	RECEPTOR TRANSMITTER RT-594A-11000	1	1	
1-44	100100-044	RECEPTOR TRANSMITTER RT-594A-11000	1	1	
1-45	100100-045	RECEPTOR TRANSMITTER RT-594A-11000	1	1	
1-46	100100-046	RECEPTOR TRANSMITTER RT-594A-11000	1	1	
1-47	100100-047	RECEPTOR TRANSMITTER RT-594A-11000	1	1	
1-48	100100-048	RECEPTOR TRANSMITTER RT-594A-11000	1	1	
1-49	100100-049	RECEPTOR TRANSMITTER RT-594A-11000	1	1	
1-50	100100-050	RECEPTOR TRANSMITTER RT-594A-11000	1	1	
1-51	100100-051	RECEPTOR TRANSMITTER RT-594A-11000	1	1	
1-52	100100-052	RECEPTOR TRANSMITTER RT-594A-11000	1	1	
1-53	100100-053	RECEPTOR TRANSMITTER RT-594A-11000	1	1	
1-54	100100-054	RECEPTOR TRANSMITTER RT-594A-11000	1	1	
1-55	100100-055	RECEPTOR TRANSMITTER RT-594A-11000	1	1	
1-56	100100-056	RECEPTOR TRANSMITTER RT-594A-11000	1	1	
1-57	100100-057	RECEPTOR TRANSMITTER RT-594A-11000	1	1	
1-58	100100-058	RECEPTOR TRANSMITTER RT-594A-11000	1	1	
1-59	100100-059	RECEPTOR TRANSMITTER RT-594A-11000	1	1	
1-60	100100-060	RECEPTOR TRANSMITTER RT-594A-11000	1	1	
1-61	100100-061	RECEPTOR TRANSMITTER RT-594A-11000	1	1	
1-62	100100-062	RECEPTOR TRANSMITTER RT-594A-11000	1	1	
1-63	100100-063	RECEPTOR TRANSMITTER RT-594A-11000	1	1	
1-64	100100-064	RECEPTOR TRANSMITTER RT-594A-11000	1	1	
1-65	100100-065	RECEPTOR TRANSMITTER RT-594A-11000	1	1	
1-66	100100-066	RECEPTOR TRANSMITTER RT-594A-11000	1	1	
1-67	100100-067	RECEPTOR TRANSMITTER RT-594A-11000	1	1	
1-68	100100-068	RECEPTOR TRANSMITTER RT-594A-11000	1	1	
1-69	100100-069	RECEPTOR TRANSMITTER RT-594A-11000	1	1	
1-70	100100-070	RECEPTOR TRANSMITTER RT-594A-11000	1	1	
1-71	100100-071	RECEPTOR TRANSMITTER RT-594A-11000	1	1	
1-72	100100-072	RECEPTOR TRANSMITTER RT-594A-11000	1	1	
1-73	100100-073	RECEPTOR TRANSMITTER RT-594A-11000	1	1	
1-74	100100-074	RECEPTOR TRANSMITTER RT-594A-11000	1	1	
1-75	100100-075	RECEPTOR TRANSMITTER RT-594A-11000	1	1	
1-76	100100-076	RECEPTOR TRANSMITTER RT-594A-11000	1	1	
1-77	100100-077	RECEPTOR TRANSMITTER RT-594A-11000	1	1	
1-78	100100-078	RECEPTOR TRANSMITTER RT-594A-11000	1	1	
1-79	100100-079	RECEPTOR TRANSMITTER RT-594A-11000	1	1	
1-80	100100-080	RECEPTOR TRANSMITTER RT-594A-11000	1	1	
1-81	100100-081	RECEPTOR TRANSMITTER RT-594A-11000	1	1	
1-82	100100-082	RECEPTOR TRANSMITTER RT-594A-11000	1	1	
1-83	100100-083	RECEPTOR TRANSMITTER RT-594A-11000	1	1	
1-84	100100-084	RECEPTOR TRANSMITTER RT-594A-11000	1	1	
1-85	100100-085	RECEPTOR TRANSMITTER RT-594A-11000	1	1	
1-86	100100-086	RECEPTOR TRANSMITTER RT-594A-11000	1	1	
1-87	100100-087	RECEPTOR TRANSMITTER RT-594A-11000	1	1	
1-8					

SECTION II
GROUP ASSEMBLY PARTS LIST

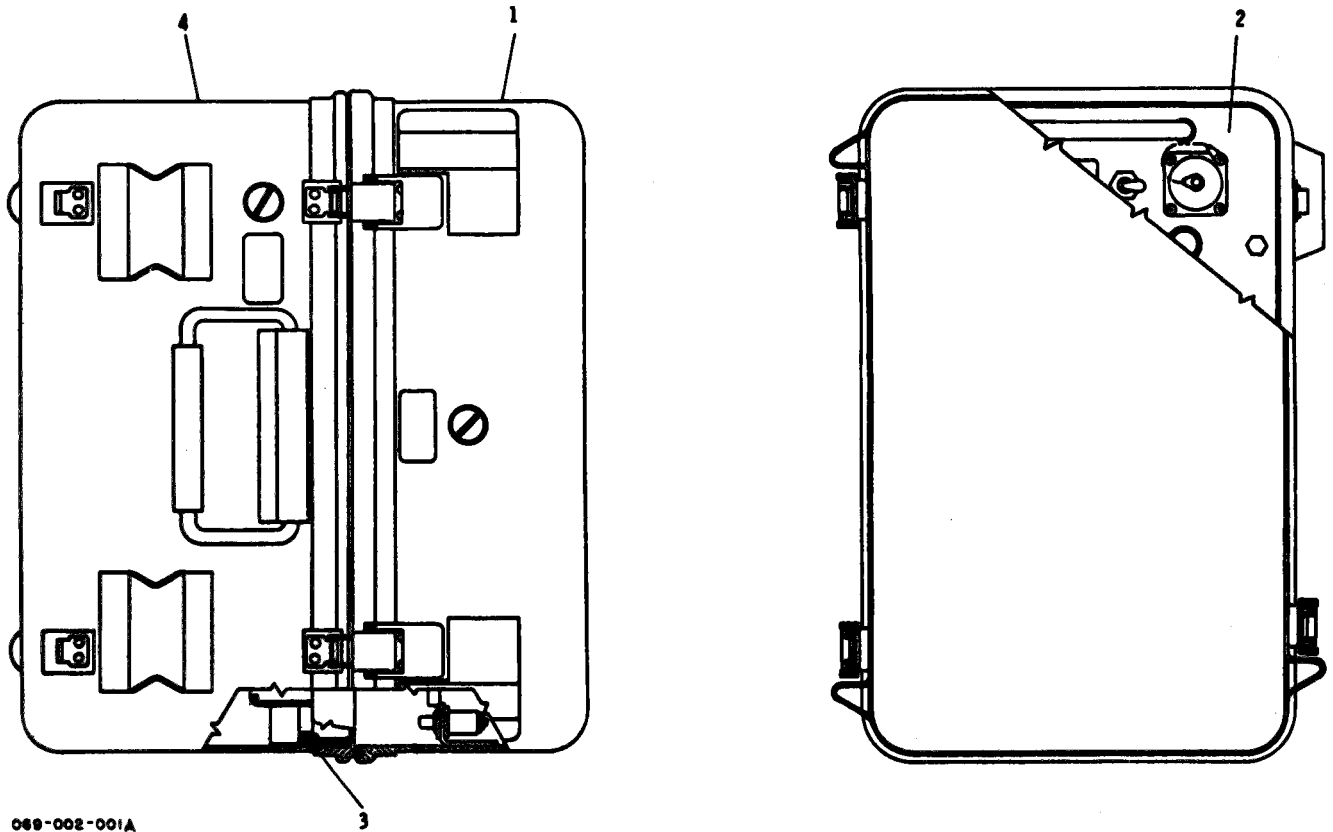

069-002-001A

Figure 6-1. Transponder Set Test Set AN/APM-378

FIGURE & INDEX No.	PART NUMBER	1	2	3	4	5	6	7	DESCRIPTION	UNITS PER ASSY	USABLE ON CODE
6-1-	4035500-0501								TEST SET, Transponder Set AN/APM-378	1	
-1	4035451-0501								. COVER, Test set (see fig. 6-2 for breakdown)	1	
-2	4035452-0501								. TEST SET, Transponder (see fig. 6-3 for breakdown)	1	
	AN3C24A								. . BOLT (AP)	Ref	
	NAS1598C3Y								. . WASHER (AP)	Ref	
	MS15795-842								. . WASHER (AP)	Ref	
	RNF100-1-4								. . INSULATION, Sleeving (AP) (08795) (06845 spec cont dwg 4018384-0721).	Ref	
-3	10-04-2737-1250								. . GASKET, RF (18565) (06845 spec cont dwg 4042886-0701)	AR	
-4	D10887-2								. . CASE ASSY (19178) (06845 spec cont dwg 4019610-0701)	1	

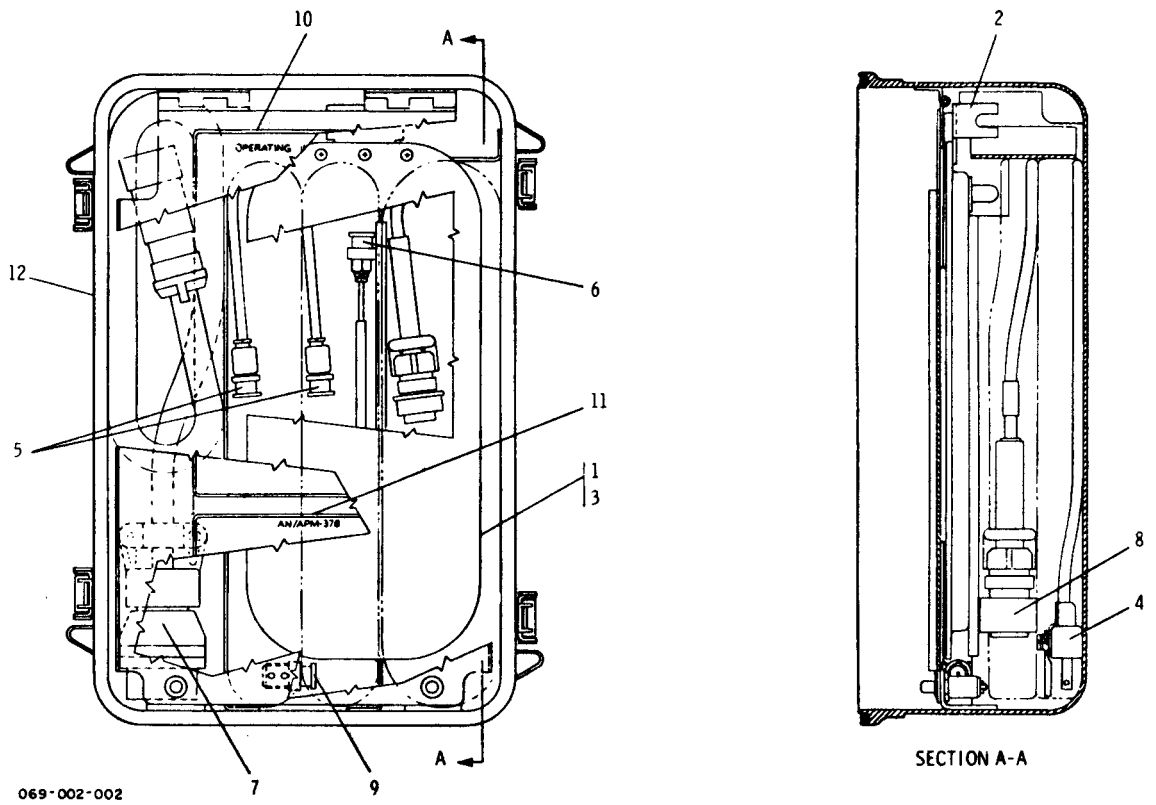

Figure 6-2. Test Set Cover

FIGURE & INDEX NO.	PART NUMBER	1	2	3	4	5	6	7	DESCRIPTION	UNITS PER ASSY	USABLE ON CODE
6-2-	4035451-0501								COVER, TEST SET (SEE FIG. 6-1 FOR NHA)		REF
-1	4035456-0501								.ANTENNA ASSY		1
-2	4035507-0001								..BRACKET		1
	MS24693C27								..SCREW (AP)		3
	MS35649-264								..NUT (AP)		3
	MS35338-136								..WASHER (AP)		3
	MS15795-806								..WASHER (AP)		3
-3	15D01800								..ANTENNA (82152) (06845 SPEC CONT DWG 4019522-0701)		
-4	4035453-0501								.CABLE ASSY, POWER (SEE FIG. 6-4 FOR BREAKDOWN)		1
-5	4035454-0501								.CABLE ASSY, RF		2
	M39012-16-0001								..CONNECTOR		2
	RG223U								..CABLE, COAXIAL		AR
-6	4035455-0501								.CABLE ASSY, RF		1
	58-007-0000								..CONNECTOR, BNC (98291) (06845 SPEC CONT DWG 2026445-0701)		
	RG316U								..CABLE, COAXIAL		AR
	2075059-0005								..MARKER, CABLE		1
-7	4035457-0501								.CABLE ASSY, SPECIAL PURPOSE		1
-8	4035549-0501								.CABLE ASSY, POWER (SEE FIG. 6-5 FOR BREAKDOWN)		1
-9	4075C51								.DUMMY CONNECTOR (74868) (06845 SPEC CONT DWG 2027369-0701)		1
-10	2075057-0701								.INSTRUCTION PLATE		1
-11	2075058-0701								.DECAL, EQUIPMENT LIST		1
-12	4019510-0702								.COVER		1

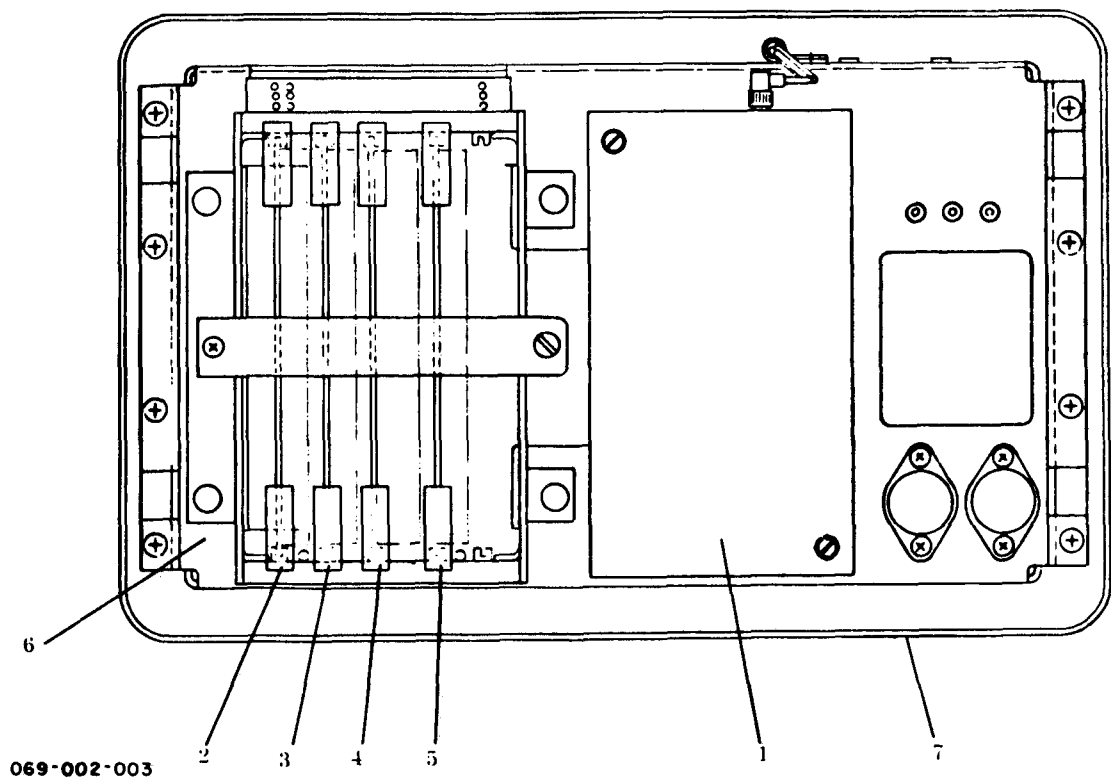

Figure 6-3. Transponder Set Test Set AN/APM-378, Rear View

FIGURE & INDEX NO.	PART NUMBER								UNITS PER ASSY	USABLE ON C
		1	2	3	4	5	6	7		
6-3-	4035452-0501	TEST SET, Transponder (see fig. 6-1 for NHA)							Ref	
-1	4035544-0501	. RF MODULE ASSY (see fig. 6-9 for breakdown)							1	
	4035493-0001	. . SCREW, Captive (AP)							Ref	
	MS16632-4025	. . RING, Retaining (AP)							Ref	
-2	4035471-0701	. DECODER MODULE (see fig. 6-10 for breakdown)							1	
-3	4035522-0701	. INTERROGATOR MODULE (see fig. 6-10 for breakdown)							1	
-4	4035523-0701	. SYNCHRONIZER MODULE (see fig. 6-10 for breakdown)							1	
-5	4035524-0701	. EVA MODULE (see fig. 6-10 for breakdown)							1	
-6	4035547-0501	. CHASSIS ASSY (see fig. 6-8 for breakdown)							1	
	MS51957-42	. SCREW (AP)							8	
-7	4035546-0501	. FRONT PANE ASSY (see fig. 6-6 for breakdown)							1	

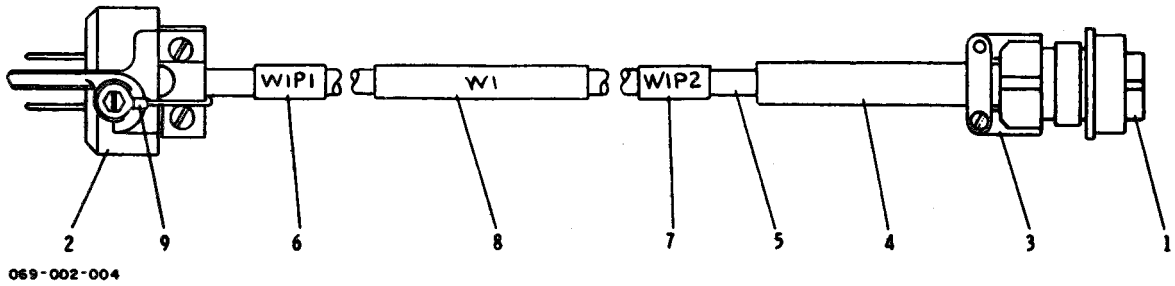
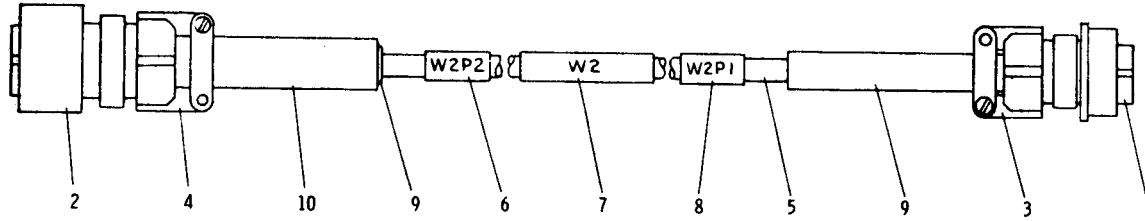

Figure 6-4. Power Cable Assembly
(PN 4035453-0501)

FIGURE & INDEX NO.	PART NUMBER	1 2 3 4 5 6 7 DESCRIPTION	UNITS PER ASSY	USABLE ON CODE
6-4-	4035453-0501	CABLE ASSEMBLY, Power (see fig. 6-2 for NHA)		
-1	MS3106A14S5S	. CONNECTOR	1	
-2	UP131M	. CONNECTOR	1	
-3	MS3057-6A	. CLAMP	1	
-4	MS3420-6	. BUSHING	1	
-5	CO-03LGF3-18-0260	. CABLE	AR	
-6	2075059-0006	. MARKER, Cable	1	
-7	2075059-0007	. MARKER, Cable	1	
-8	2075059-0001	. MARKER, Cable	1	
-9	MS25036-101	. LUG, Crimp	1	



069-002-005

Figure 6-5. Power Cable Assembly
(PN 4035549-0501)

FIGURE & INDEX NO.	PART NUMBER	1 2 3 4 5 6 7 DESCRIPTION	UNITS PER A	USABLE ON C
6-5-	4035549-0501	CABLE ASSEMBLY, Power (see fig. 6-2 for NHA)	Ref	
-1	MS3106A14S5S	. CONNECTOR	1	
-2	MS3107A16-11P	. CONNECTOR	1	
-3	MS3057-6A	. CLAMP	1	
-4	MS3057-8A	. CLAMP	1	
-5	CO-02LLF2-18-0250	. CABLE	AR	
-6	2075059-0009	. MARKER, Cable	1	
-7	2075059-0002	. MARKER, Cable	1	
-8	2075059-0008	. MARKER, Cable	1	
-9	MS3420-6	. BUSHING	2	
-10	MS3420-8	. BUSHING	1	

FIGURE & INDEX NO.	PART NUMBER	1	2	3	4	5	6	7	DESCRIPTION	UNITS PER ASSU	USABLE ON CODE
6-6-	4035546-0501								FRONT PANEL ASSY (SEE FIG. 6-3 FOR NHA)	REF	
-1	MS3112E18-32S								.CONNECTOR	1	
-2	MS3102E14S5P								.CONNECTOR	1	
	MS51957-17								.SCREW (AP)	2	
	MS51957-16								.SCREW (AP)	6	
	NAS1515H04								.ASHER (AP)	8	
	22NRTM40								.NUT, SELF LOCKING (AP) (72962) (06845 SPEC CONT DWG 0652214-0701)	8	
-3	4042881-0501								.CHASSIS, RFI FILTER	1	
-4	4042883-0701								.SHIELD, RFI FILTER	1	
-5	4042882-0001								.COVER, RFI FILTER	1	
	MS51957-28								.SCREW (AP)	4	
	MS15795-804								.WASHER (AP)	8	
-6	10-40450-18S								.GASKET (77820) (06845 SPEC CONT DWG 4019400-0702)	1	
-7	10-40450-14S								.GASKET (77820) (06845 SPEC CONT DWG 4019400-0701)	1	
-8	MS3118-18C								.CAP, CONNECTOR	1	
-9	MS25043-14D								.CAP, CONNECTOR	1	
-10	2075079-0501								.CABLE ASSY (SEE FIG. 6-7 FOR BREAKDOWN)	1	
-11	M39019-1-31								.CIRCUIT BREAKER	1	
-12	M39019-3-27								.CIRCUIT BREAKER	1	
-13	2808BA1BESP								.SWITCH, PUSHBUTTON (91812) (06845 SPEC CONT DWG 4019456-0701)	4	
	MS51959-2								.SCREW (AP)	8	
-14	MS24523-30								.SWITCH, TOGGLE	1	
	MS25196-1								.PANEL SEAL (AP)	1	
-15	MS24523-31								.SWITCH, TOGGLE	1	
	MS25196-1								.PANEL SEAL (AP)	1	
-16	4019391-0701								.SWITCH, ROTARY	3	
-17	MS24523-23								.SWITCH, TOGGLE	2	
	MS25196-1								.PANEL SEAL (AP)	2	
-18	LH89-1								.LAMPHOLDER	2	
-19	330								.LAMP (08806) (06845 SPEC CONT DWG 4019409-0702)	2	
-20	LC35YT2								.LENS	1	
-21	LC35RT2								.LENS	1	
-22	VM300S101								.LAMPHOLDER (87034) (06845 SPEC CONT DWG 4019435-0701)	1	
-23	VM300S102								.LAMPHOLDER (87034) (06845 SPEC CONT DWG 4019435-0702)	1	
-24	756								.LAMP (08806) (06845 SPEC CONT DWG 4010499-0717)	2	
-25	10509A1032-2								.HANDLE (06540) (06845 SPEC CONT DWG 4035525-0701)	2	
	NAS 1598C3Y								.WASHER (AP)	4	
	MS51958-65								.SCREW (AP)	4	
	MS15795-842								.WASHER (AP)	4	
	MS35338-138								.WASHER (AP)	4	

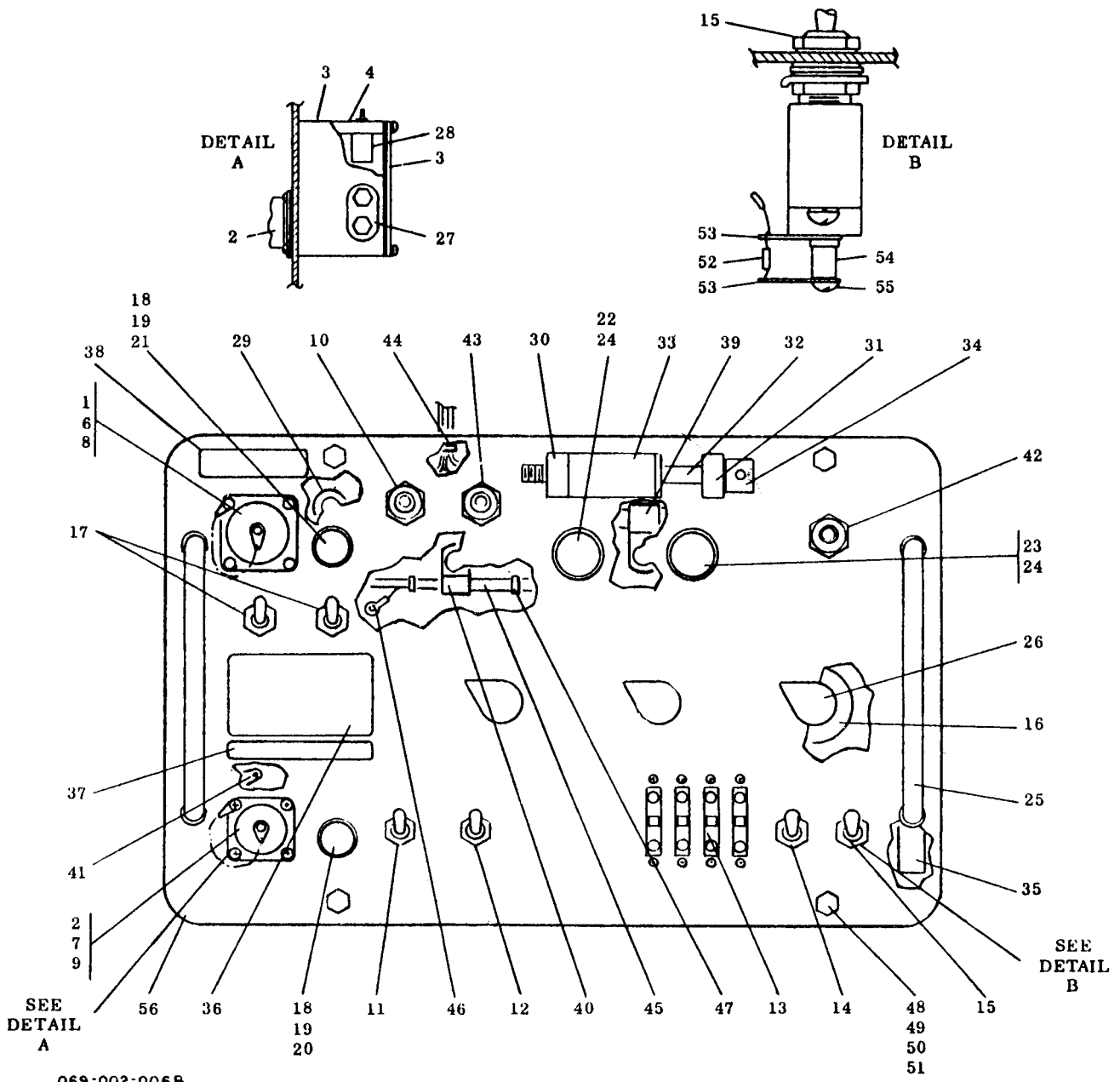
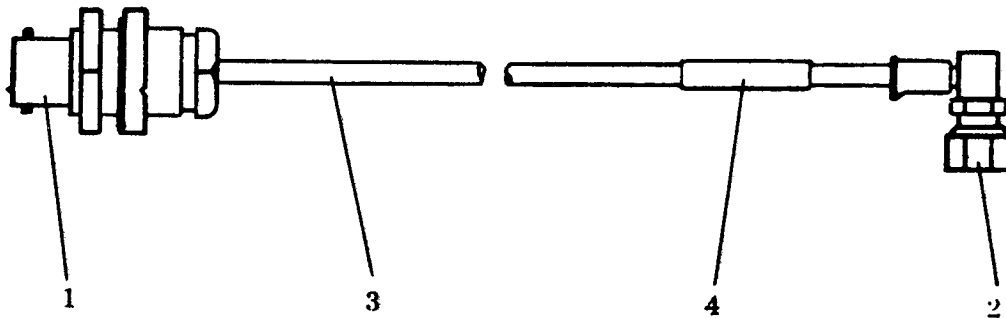

Figure 6-6. Front Panel Assembly

FIGURE & INDEX NO.	PART NUMBER	1	2	3	4	5	6	7	DESCRIPTION	UNITS PER ASSY	USABLE ON CODE
6-6-26 -27	MS91528-1K2B 1200-074								.KNOB .FILTER, DC (12294) (06845 SPEC CONT DWG 4019407-0701)	3 2	
-28	9000-100-0037								.FILTER, AC (12294) (06845 SPEC CONT DWG 4019444-0701)	2	
-29	SE26XF03								.TERMINAL	2	
	MS51957-32								.SCREW (AP)	1	
	MS35338-136								.WASHER (AP)	1	
-30	4035496-0501								.BLOCK, MOUNTING	1	
	MS3212-12								.SCREW (AP)	2	
-31	4035495-0001								.BLOCK, MOUNTING	1	
	MS3212-12								.SCREW (AP)	2	
-32	4019513-0001								.SHAFT, THREADED	1	
-33	4019514-0001								.SPACER, SLEEVE	1	
-34	4035458-0001								.LEVER, OPERATING	1	
	AN565D632H2								.SETSCREW (AP)	2	
-35	4035460-0501								.SPACER, THREADED	2	
-36	4035504-0701								.PLATE, IDENTIFICATION	1	
-37	4035505-0701								.PLATE, SERIAL NUMBER	1	
-38	4042888-0001								.PLATE, CAUTION	1	
-39	MS25281R6								.CLAMP, LOOP	1	
	MS51957-43								.SCREW (AP)	1	
	MS15795-841								.WASHER (AP)	1	
	MS35338-137								.WASHER (AP)	1	
-40	MS25281R3								.CLAMP, LOOP	1	
	MS51957-43								.SCREW (AP)	1	
	MS15795-841								.WASHER (AP)	1	
	MS35338-137								.WASHER (AP)	1	
-41	MS77068-2								.TERMINAL LUG	1	
	MS51957-26								.SCREW (AP)	1	
-42	2075079-0502								.CABLE ASSY (SEE FIG. 6-7 FOR BREAKDOWN)	1	
-43	2075079-0503								.CABLE ASSY (SEE FIG. 6-7 FOR BREAKDOWN)	1	
-44	MS3367-4-9								.STRAP, TIEDOWN	2	
-45	2075056-0501								.WIRING HARNESS	1	
-46	MS25036-101								.TERMINAL LUG	12	
-47	MS3367-4-9								.STRAP, TIEDOWN	80	
-48	AN3C24A								.BOLT (AP)	4	
-49	NAS1598C3Y								.WASHER (AP)	4	
-50	MS15795-842								.WASHER (AP)	4	
-51	RNF100-1-4								.INSULATION, SLEEVING (AP) (08795) (06845 SPEC CONT DWG 4018384-0721)	4	
-52	RCR07G331JS								.RESISTOR	1	
-53	MS77067-2								.TERMINAL (AP)	2	
-54	3330-53-1								.TERMINAL (AP) (17117) (06845 SPEC CONT DWG 4042885-0701)	1	
-55	2074099-2301								.SCREW (AP)	1	
-56	4035470-0501								.PANEL, FRONT	1	



069-002-007

Figure 6-7. Cable Assembly

FIGURE & INDEX NO.	PART NUMBER								UNITS PER A	USABLE ON C
		1	2	3	4	5	6	7		
6-7-	2075079-0501	CABLE ASSEMBLY (see fig. 6-6 for NHA)							Ref	A
	2075079-0502	CABLE ASSEMBLY (see fig. 6-6 for NHA)							Ref	B
	2075079-0503	CABLE ASSEMBLY (see fig. 6-6 for NHA)							Ref	C
-1	9950-6	. CONNECTOR (95712) (06845 spec cont dwg 4019389-0701)							1	A B C
-2	50-028-0000	. CONNECTOR (98291) (06845 spec cont dwg 4035539-0701)							1	A B C
-3	RG316U	. CABLE, Coaxial							AR	A B C
-4	2075059-0012	. MARKER, Cable							1	A
	2075059-0013	. MARKER, Cable							1	B
	2075059-0014	. MARKER, Cable							1	C

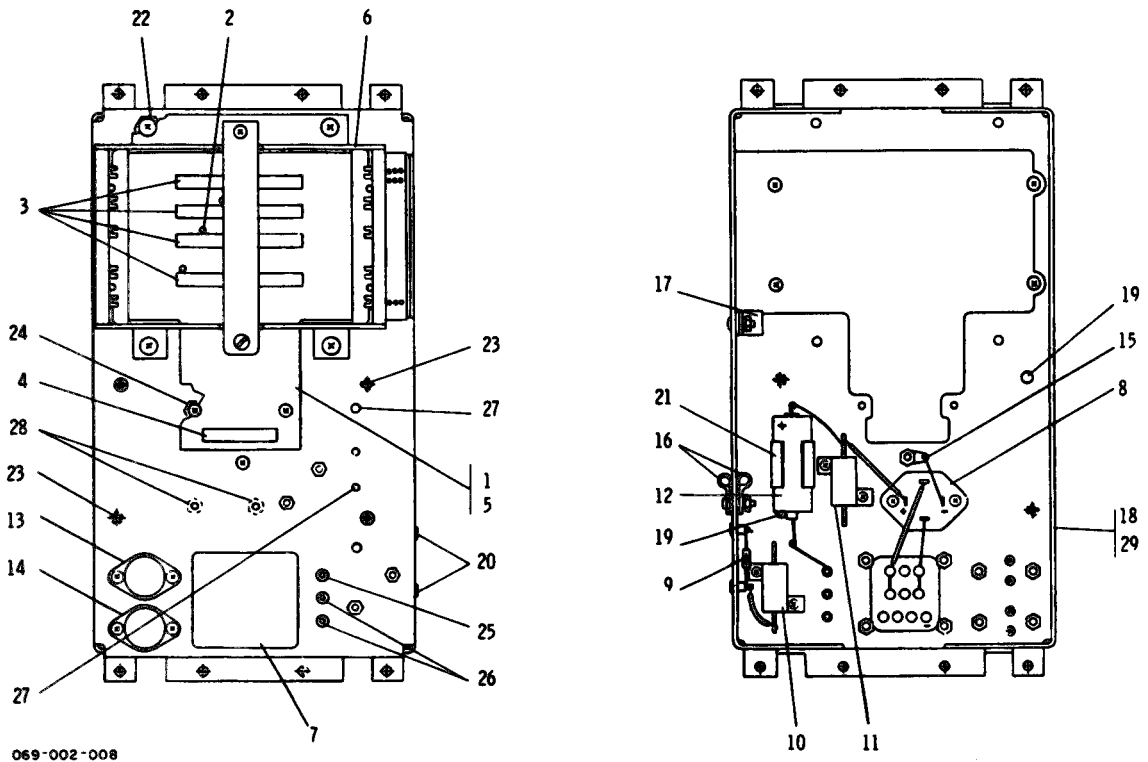
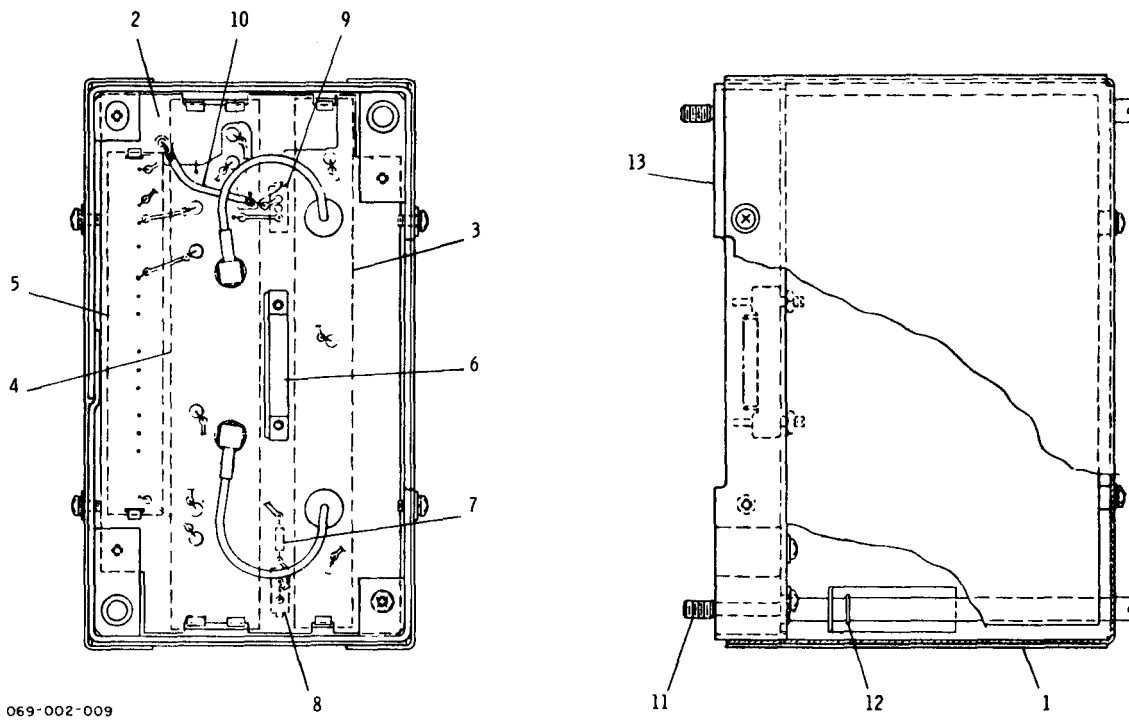

Figure 6-8. Chassis Assembly

FIGURE & INDEX NO.	PART NUMBE	1 2 3 4 5 6 7 DESCRIPTION	UNITS PER ASSY	USABLE ON CODE
6-8-	4035547-0501	CHASSIS ASSEMBLY (see fig. 6-3 for NHA)	Ref	
-1	4035450-0501	. PRINTED WIRING BOARD ASSEMBLY	1	
	MS35338-136	. WASHER (AP)	6	
	795-806	. WASHER (AP)	6	
	MS51957-27	. SCREW (A P)	6	
-2	4035474-0001	. . PIN, Locating	4	
-3	NCD200092-01	. . CONNECTOR (16512) (06845 spec cont dwg 4019417-0701)	4	
-4	NCD200147	. . CONNECTOR (16512) (06845 spec cont dwg 4019485-0701)	1	
-5	4035482-0001	. . PRINTED WIRING BOARD	1	
-6	3-00005-114-1	. PRINTED CIRCUIT CARD ENCLOSURE (ESF) (06845 spec cont dwg 4019511-0701)	1	
	MS51958-61	. SCREW (A P)	4	
	MS35338-138	. WASHER (AP)	4	
	MS15753-842	. WASHER (A	4	
-7	H935	TRANSFORMER, Power, step-down (80223) (06845 spec cont dwg 4010699-0701)	1	

FIGURE & INDEX NO.	PART NUMBER	1	2	3	4	5	6	7	DESCRIPTION	UNITS PER ASSY	USABLE ON CODE
6-8-	MS35649-264								.NUT (AP)	4	
	MS35338-136								.WASHER (AP)	4	
	MS15795-806								.WASHER (AP)	4	
-8	MDA952-2								.RECTIFIER, SEMICONDUCTOR DEVICE, DIODE, BRIDGE ASSY (04713) (06845 SPEC CONT DWG 2056403-0701)	1	
	MS51957-18								.SCREW (AP)	2	
	MS35338-135								.WASHER (AP)	2	
-9	1N5550								.DIODE	1	
-10	RER70F9R09M								.RESISTOR	1	
	MS51957-15								.SCREW (AP)	2	
	MS15795-804								.WASHER (AP)	2	
	MS35338-135								.WASHER (AP)	2	
	MS35649-244								.NUT (AP)	2	
-11	RER70F12ROM								.RESISTOR	1	
	MS51957-15								.SCREW (AP)	2	
	MS15795-804								.WASHER (AP)	2	
	MS35338-135								.WASHER (AP)	2	
	MS35649-244								.NUT (AP)	2	
-12	M39018-03-0731								.CAPACITOR	1	
-13	7812KM								.INTEGRATED CIRCUIT, VOLTAGE REGULATOR (07263) (06845 SPEC CONT DWG 4019404-0702)	1	
	MS51957-28								.SCREW (AP)	2	
	MS35335-58								.WASHER (AP)	2	
	MS35649-264								.NUT (AP)	2	
-14	7805KM								.INTEGRATED CIRCUIT, VOLTAGE REGULATOR (07263) (06845 SPEC CONT DWG 4019404-0701)	1	
	MS51957-28								.SCREW (AP)	2	
	MS35335-58								.WASHER (AP)	2	
	MS35649-264								.NUT (AP)	2	
-15	MS77068-2								.LUG, TERMINAL	1	
	MS51957-26								.SCREW (AP)	1	
	MS35649-264								.NUT (AP)	1	
-16	MS25281R3								.CLAMP, LOOP	2	
	MS51957-45								.SCREW (AP)	1	
	MS35338-137								.WASHER (AP)	1	
	MS35649-284								.NUT (AP)	1	
-17	MS25281R6								.CLAMP, LOOP	1	
	MS51957-45								.SCREW (AP)	1	
	MS35338-137								.WASHER (AP)	1	
	MS35649-284								.NUT (AP)	1	
-18	4035503-0501								.CHASSIS, ELEC EQUIPMENT	1	
-19	4035483-0001								.PIN, GUIDE	2	
-20	SL201-197F								.TERMINAL STUD, INSULATED (12615) (06845 SPEC CONT DWG 4035502-0701)	2	

FIGURE & INDEX NO.	PART NUMBER	1	2	3	4	5	6	7	DESCRIPTION	UNITS PER ASSY	USABLE ON CODE
6-8-21	100-200-12A31								..CLIP, SPRING TENSION (99378) (06845 SPEC CONT DWG 4010670-0713	1	
-22	MS16535-133N NCN10-1-2								..RIVET (AP) ..NUT, CAPTIVE (07886) (06845 SPEC CONT DWG 2005535-0716)	2	
-23	NCN10-8-2								..NUT, SELF-LOCKING, CLINCH, FLOATING (07886) (06845 SPEC CONT DWG 4035501-0701)	4	
-24	NCN6-1-2								..NUT, CAPTIVE (07886) (06845 SPEC CONT DWG 2005535-0706)	2	
-25	016-2000-00- 0-140								..JACK, TIP (98291) (06845 SPEC CONT DWG 2043782-0703)	2	
-26	016-2000-00-								..JACK, TIP (98291) (06845 SPEC CONT DWG 2043782-0713)	1	
-27	SL241-263F								..TERMINAL STUD, INSULATED (12615) (06845 SPEC CONT DWG 4035502-0703)	2	
-28	MS3214-3								..NUT, CLINCH	2	
-29	4035459-0001								..CHASSIS, ELEC EQUIPMENT	1	



069-002-009

Figure 6-9. RF Module Assembly

FIGURE & INDEX NO.	PART NUMBER	1	2	3	4	5	6	7	DESCRIPTION	UNITS PER ASSY	USABLE ON CODE
6-9-	4035544-0501								RF MODULE ASSEMBLY (SEE FIG. 6-3 FOR NHA)	REF	
-1	4035489-0501								.COVER, PROTECTIVE	1	
	MS51957-13								.SCREW (AP)	4	
	MS35338-135								.WASHER (AP)	4	
	MS15795-804								.WASHER (AP)	4	
-2	4035494-0001								.PRINTED WIRING BOARD	1	
	MS51957-13								.SCREW (AP)	4	
	MS15795-804								.WASHER (AP)	4	
-3	4035534-0701								.OSCILLATOR MODULE	1	
	MS51957-12								.SCREW (AP)	2	
	MS35338-135								.WASHER (AP)	2	
	MS15795-804								.WASHER (AP)	2	
-4	4035535-0701								.MICROSTRIP MODULE	1	
	MS51957-12								.SCREW (AP)	2	
	MS35338-135								.WASHER (AP)	2	
	MS15795-804								.WASHER (AP)	2	
-5	4035536-0701								.IF. VIDEO MODULE	1	
	MS51957-12								.SCREW (AP)	2	
	MS35338-135								.WASHER (AP)	2	
	MS15795-804								.WASHER (AP)	2	
-6	NCD200149								.CONNECTOR, PLUG, ELECTRICAL (16512) (06845 SPEC CONT DWG 4019486-0701)	1	
	MS51858-2								.NUT (AP)	2	
-7	RCR07G201JS								.RESISTOR	1	
-8	RT22C2X102								.RESISTOR	1	
-9	RT22C2X103								.RESISTOR	1	
-10	2075073-0001								.CABLE, COAX	1	
-11	4035493-0001								.SCREW, CAPTIVE	2	
-12	MS16632-4025								.RING, RETAINING	2	
-13	4035480-0501								.HOUSING, RF	1	

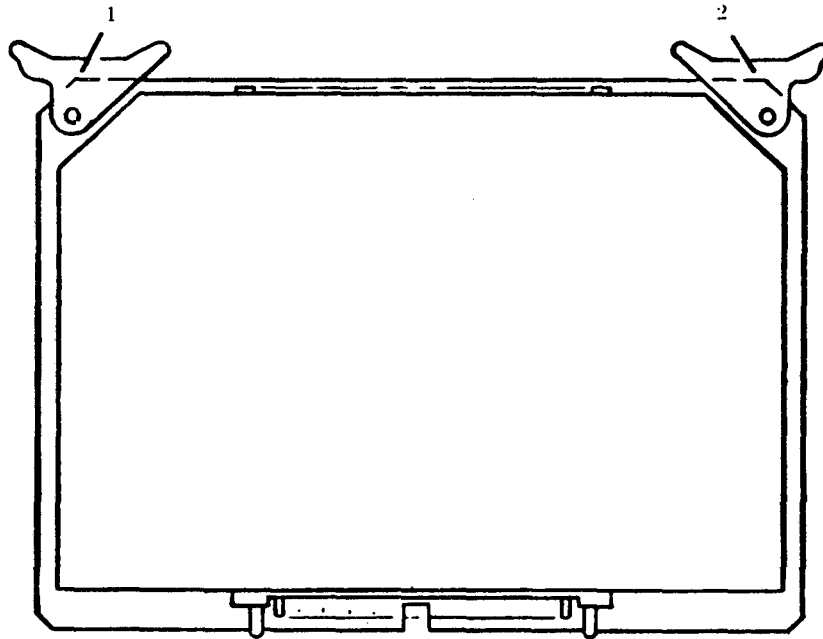

069-002-010

Figure 6-10. Module Assemblies

FIGURE & INDEX NO.	PART NUMBER	1 2 3 4 5 6 7 DESCRIPTION	UNITS PER ASSY	USABLE ON C
6-10-	4035471-0701	DECODER MODULE (see fig. 6-3 for NHA)	Ref	A
	4035522-0701	INTERROGATOR MODULE (see fig. 6-3 for NHA)	Ref	B
	4035523-0701	SYNCHRONIZER MODULE (see fig. 6-3 for NHA)	Ref	C
	4035524-0701	EVALUATOR MODULE	Ref	D
	-1 S202	. EJECTOR (18677)(06845)spec spec cont dwg 4035472-0705	4	ABCD
	-2 S202	. EJECTOR (18677)(06845)spec spec cont dwg 4035472-0701, alter from 4035472-0705	1	A
	S202	. EJECTOR (18677)(06845)spec spec cont dwg 4035472-0702, alter from 4035472-0705	1	B
	S202	. EJECTOR (18677)(06845)spec spec cont dwg 4035472-0703, alter from 4035472-0705	1	C
	S202	. EJECTOR (18677)(06845)spec spec cont dwg 4035472-0704, alter from 4035472-0705	1	D

SECTION III

NUMERICAL INDEX

PART NUMBER	FIGURE & INDEX NO.	CODES	PART NUMBER	FIGURE & INDEX NO.	CODES
AN3C24A	6-6-48	PAGZZ	MS3212-12	6-6	PAGZZ
AN565D632H2	6-6	XBGZZN	MS3214-3	6-8-28	PAGZZ
CO-02LGF3-18-0260	6-4-5		MS3367-4-9	6-6-44	PAGZZ
CO-02LLF2-18-0250	6-5-5			6-6-47	
D10887-2	6-1-4	XBGZZ	MS3420-6	6-4-4	PAGZZ
H935	6-8-7	PAGZZ		6-5-9	
LC35RT2	6-6-21	PAGZZ	MS3420-8	6-5-10	PAGZZ
LC35YT2	6-6-20	PAGZZ	MS35335-58	6-8	PAGZZ
LH89-1	6-6-18	PAGZZ	MS35338-135	6-8	PAGZZ
MDA952-2	6-8-8	PAGZZ		6-9	
MS15795-804	6-6	PAGZZ		6-2	PAGZZ
	6-8			6-6	
	6-9		MS35338-137	6-8	
MS15795-806	6-2	PAGZZ		6-6	PAGZZ
	6-8		MS35338-138	6-8	
MS15795-841	6-6	PAGZZ		6-6	PAGZZ
MS15795-842	6-6-50	PAGZZ	MS35649-244	6-8	PAGZZ
	6-6		MS35649-264	6-2	PAGZZ
	6-8			6-8	
MS16535-133N	6-8	PAGZZ	MS35649-284	6-8	PAGZZ
MS16632-4025	6-9-12	PAGZZ	MS51858-2	6-9	
MS24523-23	6-6-17	PAGZZ	MS51957-12	6-9	PAGZZ
MS24523-30	6-6-14	PAGZZ	MS51957-13	6-9	PAGZZ
MS24523-31	6-6-15	PAGZZ	MS51957-15	6-8	PAGZZ
MS24693C27	6-2	PAGZZ	MS51957-16	6-6	PAGZZ
MS25036-101	6-4-9	PAGZZ	MS51957-17	6-6	PAGZZ
	6-6-46		MS51957-18	6-8	PAGZZ
MS25043-14D	6-6-6	XBGZZN	MS51957-26	6-6	PAGZZ
MS25196-1	6-6	PAGZZ		6-8	
MS25281R3	6-6-40	PAGZZ	MS51957-27	6-8, 6-2A	PAGZZ
	6-8-16		MS51957-28	6-8	PAGZZ
MS25281R6	6-6-39	PAGZZ	MS51957-32	6-6	PAGZZ
	6-8-17		MS51957-42	6-3	PAGZZ
MS3057-6A	6-4-3	PAGZZ	MS51957-43	6-6	PAGZZ
	6-5-3		MS51957-45	6-8	PAGZZ
MS3057-8A	6-5-4	PAGZZ	MS51958-61	6-8	PAGZZ
MS3102E14S5P	6-6-2	PAGZZ	MS51958-65	6-6	PAGZZ
MS3106A14S5S	6-4-1	PAGZZ	MS51959-2	6-6	PAGZZ
	6-5-1		MS77067-2	6-6-53	
MS3107A16-11P	6-5-2	PAGZZ	MS77068-2	6-6-41	PAGZZ
MS3112E18-32S	6-6-1	PAGZZ		6-8-15	
			MS91528-1K2B	6-6-26	PAGZZ
MS3118-18C	6-6-8	XBGZZN	MS39012-16-0001	6-2	

PART NUMBER	FIGURE & INDEX NO.	CODES	PART NUMBER	FIGURE & INDEX NO.	CODES
M39018-03-0731	6-8-12	PAGZZ	2074099-2301	6-6-55	
M39019-1-31	6-6-11	PAGZZ	2075056-0501	6-6-45	XBGGG
M39019-3-27	6-6-12	PAGZZ	2075057-0701	6-2-10	MDGZZ
NAS1515H04	6-6	PAGZZ	2075058-0701	6-2-11	MDGZZ
NAS1598C3Y	6-6-49	PAGZZ	2075059-0001	6-4-8	MDGZZ
NAS1598C34	6-3		2075059-0002	6-5-7	MDGZZ
NCD200092-01	6-8-3	PAGZZ	2075059-0005	6-2	
NCD200147	6-8-4	PAGZZ	2075059-0006	6-4-6	MDGZZ
NCD200149	6-9-6	PAGZZ	2075059-0007	6-4-7	MDGZZ
NCN10-1-2	6-8-22	PAGZZ	2075059-0008	6-5-8	MDGZZ
NCN10-8-2	6-8-23	XBGZZN	2075059-0009	6-5-6	MDGZZ
NCN6-1-2	6-8-24	PAGZZ	2075059-0012	6-7-4	
RCR07G201JS	6-9-7	PAGZZ	2075059-0013	6-7-4	
RCR07G331JS	6-6-52		2075059-0014	6-7-4	
RER70F12ROM	6-8-11	PAGZZ	2075073-0001	6-9-10	
RER70F9R09M	6-8-10	PAGZZ	2075079-0501	6-6-10	PAGZZ
RG223U	6-2		2075079-0502	6-6-42	PAGZZ
RG316U	6-2		2075079-0503	6-6-43	PAGZZ
	6-7-3		22NKT40	6-6	PAGZZ
RNF100-1-4	6-6-51		2808BALBESP	6-6-13	PAGZZ
RT22C2X102	6-9-8	PAGZZ	3-00005-114-1	6-8-6	
RT22C2X103	6-9-9	PAGZZ	330	6-6-19	PAOZZ
SE26XF03	6-6-29	PAGZZ	3330-53-1	6-6-54	
SL201-197F	6-8-20	PAGZZ	4010499-0717	6-6-24	PAOZZ
SL241-263F	6-8-27	PAGZZ	4010670-0713	6-8-21	PAGZZ
S202	6-10-1	PAGZZ	4010699-0701	6-8-7	PAGZZ
	6-10-2		4018384-0721	6-6	
UP131M	6-4-2	PAGZZ	4019389-0701	6-7-1	
VM300S101	6-6-22	PAGZZ	4019391-0701	6-6-16	PAGZZ
VM300S102	6-6-23	PAGZZ	4019400-0701	6-6-7	PAGZZ
016-2000-00-0-140	6-8-25	XBGZZN	4019400-0702	6-6-6	PAGZZ
016-2000-00-0-142	6-8-26	XBGZZN	4019404-0701	6-8-14	PAGZZ
0652214-0701	6-6	PAGZZ	4019404-0702	6-8-13	PAGZZ
1N5550	6-8-9	PAGZZ	4019407-0701	6-6-27	PAGZZ
10-04-2737-1250	6-1-3		4019409-0702	6-6-19	PAOZZ
10-40450-14S	6-6-7	PAGZZ	4019417-0701	6-8-3	PAGZZ
10-40450-18S	6-6-6	PAGZZ	4019435-0701	6-6-22	PAGZZ
100-200-12A31	6-8-21	PAGZZ	4019435-0702	6-6-23	PAGZZ
10509A1032-2	6-6-25	PAGZZ	4019444-0701	6-6-28	PAGZZ
1200-074	6-6-27	PAGZZ	4019456-0701	6-6-13	PAGZZ
15D01800	6-2-3	PAGZZ	4019485-0701	6-8-4	PAGZZ
2005535-0706	6-8-24	PAGZZ	4019486-0701	6-9-6	PAGZZ
2005535-0716	6-8-22	PAGZZ	4019510-0701	6-1-4	XBGGG
2026445-0701	6-2		4019510-0702	6-2-12	XBGGG
2027369-0701	6-2-9		4019511-0701	6-8-6	MDGZZ
2043782-0703	6-8-25	XBGZZN	4019513-0001	6-6-32	MDGZZ
2043782-0713	6-8-26	XBGZZN	4019514-0001	6-6-33	MDGZZ
2056403-0701	6-8-8	PAGZZ	4019522-0701	6-2-3	PAGZZ
			4035450-0501	6-8-1	XBGGG
			4035451-0501	6-1-1	XBGGG

PART NUMBER	FIGURE & INDEX NO.	CODES	PART NUMBER	FIGURE & INDEX NO.	CODES
4035452-0501	6-1-2	XBGGD	4035503-0501	6-8-18	ADGGG
4035453-0501	6-2-4	AGGGG	4035504-0701	6-6-36	MDGZZ
4035454-0501	6-2-5	PAGZZ	4035505-0701	6-6-37	MDGZZ
4035455-0501	6-2-6	PAGZZ	4035507-0001	6-2-2	MDGZZ
4035456-0501	6-2-1	AGGGG	4035522-0701	6-3-3	PAGZZ
4035457-0501	6-2-7	PAGZZ	4035523-0701	6-3-4	PAGZZ
4035458-0001	6-6-34	MDGZZ	4035524-0701	6-3-5	PAGZZ
4035459-0001	6-8-29	MDGZZ	4035525-0701	6-6-25	PAGZZ
4035460-0501	6-6-35	MDGZZ	4035534-0701	6-9-3	PAGZZ
4035470-0501	6-6-56	XBGZZ	4035535-0701	6-9-4	PAGZZ
4035471-0701	6-3-2	PAGZZ	4035536-0701	6-9-5	PAGZZ
4035472-0701	6-10-2	MGGZZ	4035539-0701	6-7-2	
4035472-0702	6-10-2	MGGZZ	4035544-0501	6-3-1	AGGGG
4035472-0703	6-10-2	MGGZZ	4035546-0501	6-3-7	AGGGG
4035472-0704	6-10-2	MGGZZ	4035547-0501	6-3-6	ADGGG
4035472-0705	6-10-1	PAGZZ	4035549-0501	6-2-8	AGGGG
4035474-0001	6-8-2	MDGZZ	4042881-0501	6-6-3	
4035480-0501	6-9-11	MDGZZ	4042882-0701	6-6-5	
4035482-0001	6-8-5	XAGZZ	4042883-0701	6-6-4	
4035483-0001	6-8-19	MDGZZ	4042885-0701	6-6-54	
4035489-0501	6-9-1	MDGZZ	4042888-0001	6-6-38	MDGZZ
4035493-0001	6-9-11	MDGZZ	4075C51	6-2-9	PAGZZ
4035494-0001	6-9-2	PAGZZ	50-028-0000	6-7-2	
4035495-0001	6-6-31	MDGZZ	58-007-0000	6-2	
4035496-0501	6-6-30	MDGZZ	756	6-6-24	PAOZZ
4035498-0701	6-1-3	XBGZZ	7805KM	6-8-14	PAGZZ
4035500-0501	6-1	PEOGD	7812KM	6-8-13	PAGZZ
4035501-0701	6-8-23	XBGZZN	9000-100-0037	6-6-28	PAGZZ
4035502-0701	6-8-20	PAGZZ	9950-6	6-7-1	
4035502-0703	6-8-27	PAGZZ			

SECTION IV

REFERENCE DESIGNATION INDEX

REF DES	FIGURE & INDEX NO.	PART NUMBER	REF DES	FIGURE & INDEX NO.	PART NUMBER
AT1	6-2-9	4075C51	S10-S11	6-6-17	MS24523-23
A1	6-3-1	4035544-0501	T1	6-8-7	H935
A1A1	6-9-6	NCD200149	U1	6-3-2	4035471-0701
A1R1	6-9-9	RT22C2X103	U2	6-3-3	4035522-0701
A1R2	6-9-8	RT22C2X102	U3	6-3-4	4035523-0701
A1R3	6-9-7	RCR07G201JS	U4	6-3-5	4035524-0701
A1U1	6-9-3	4035537-0501	U6	6-8-13	UGJ7812312
A1U2	6-9-4	4035468-0501	U7	6-8-14	UGJ7805312
A1U3	6-9-5	4035538-0501	W1	6-2-4	4035453-0501
CB1	6-6-11	M390919-1-31	W1P1	6-4-2	UP131M
CB2	6-6-12	M39019-3-27	W1P2	6-4-2	MS3106A14S5S
CR1	6-8-8	MDA952-2	W2	6-2-8	4035549-0501
CR2	6-8-9	1N5550	W2P1	6-5-1	MS3106A14S5S
C1	6-8-12	M39018-03-0731	W2P2	6-5-2	MS3107A16-11P
DS1, 2	6-6-19	330	W3	6-2-7	4035457-0501
DS3, 4	6-6-24	756	W4	6-2-5	4035454-0501
FL1, 4	6-6-27	1200-074	W5	6-2-6	4035455-0501
FL2, 3	6-6-28	9000-100-0037	W7	6-6-10	2075079-0501
J1	6-6-1	MS3112E18-32S	W8	6-6-42	2075079-0502
J2	6-6-2	MS3102E14S5P	W9	6-6-43	2075079-0503
R1	6-8-10	RER70F9R09M	XA1	6-8-4	NCD200147
R2	6-8-11	RER70F12ROM	XDS1, 2	6-6-18	LH89-1
R3	6-6-52	RCR07G331JS	XDS3	6-6-22	VM300S101
S1-S4	6-6-13	2808BA1BESP	XDS4	6-6-23	VM300S102
S5	6-6-14	MS24523-30	XU1, 2,	6-8-3	NCD200092-01
S6	6-6-15	MS24523-31	3, 4		
S7-S9	6-6-16	4019391-0701			

APPENDIX A

REFERENCES

The following is a list of applicable references that are available to the operator and repairmen of the Transponder Set Test Set AN/APM-378:

AR 750-58	Printing, Camouflage Painting, and Marking of Army Materiel.
DA Pam 310-4	Index of Technical Publications.
SB 11-558	Availability of Tool Kit, Dial Central Office Maintenance, TK-82/GT.
SB 11-573	Painting and Preservation of Supplies Available for Field Use for Electronics Command Equipment.
SB 11-604	Replacement of Tool Kits, Radar and Radio Repairman, TK-87/U and TK-88/U with Tool Kits, Electronic Equipment, TK-105/G and TK-100/G.
SB 38-100	Preservation, Packaging, Packing and Marking Materials, Supplies and Equipment Used by The Army.
SB 700-20	Army Adopted/Other Items Selected for Authorization/ List of Reportable Items.
TB SIG 291	Safety Measures to be Observed When Installing and Using Whip Antennas, Field-Type Masts, Towers and Antennas and Metal Poles That are Used With Communications, Radar and Direction Finder Equipment.
TB 43-0118	Field Instructions for Painting and Preserving Electronics Command Equipment Including Camouflage Pattern Painting of Electrical Equipment Shelters.
TM 11-5895-490-20	Organizational Maintenance Manual Receiver-Transmitters, Radio RT-859/APX-72 (NSN 5895-00-089-7179) and RT-859A/APX-72 (NSN 5895-00-160-2198) and Mountings, MT-3809/APX-72 (NSN 5895-00-063-9498) and MT-3948/APX-72 (NSN 5895-00-089-9202).
TM 11-5895-1037-12	Operator's and Organizational Maintenance Manual: Transponder Set AN/APX-100(V).
TM 11-6625-203-12	Operator's and Organizational Maintenance Manual: Multimeter AN/URM-105 and AN/URM-105C (Including Multimeter ME-77/U and ME-77C/U).
TM 11-6625-368-10	Operator's Manual: Pulse Generator Sets AN/UPM-15 and AN/UPM-15A.
TM 11-6625-444-14-1	Operator's, Organizational, Direct Support and General Support Maintenance Manual Including Repair Parts and Special Tools Lists: Voltmeter, Digital AN/GSM-64B (NSN 6625-00-022-7894) Including Plug-in Electronic Test Equipment PL-1370/GSM-64B (NSN 6625-00-137-8366).

TM 11-6625-498-12	Operator's and Organizational Maintenance Manual: Test Sets, Radio Frequency Power AN/USM-161 and AN/USM-161A (NSN 6625-00-892-5541).
TM 11-6625-654-14	Operator's, Organizational, Direct Support, and General Support Maintenance Repair Parts and Special Tools List (Including Depot Maintenance Repair Parts and Special Tools List) for Multimeter, AN/USM-223.
TM 11-6625-1703-15	Operator's Organizational, Direct Support, General Support, and Depot Maintenance Manual: Oscilloscope AN/USM-281A (NSN 6625-00-228-2201).
TM 11-6625-2610-12	Operator's and Organizational Maintenance Manual for Test Set, Radar AN/TPM-25A (NSN 6625-01-045-9988).
TM 11-6625-2808-14	Operator's Organizational, Direct Support, and General Support Maintenance Manual: Counter, Electronic, TD-1225 (V) I/U (NSN 6625-00-498-8946).
TM 38-750	The Army Maintenance Management System (TAMMS).
TM 750-244-2	Procedures for Destruction of Electronics Materiel to Prevent Enemy Use (Electronics Command).

APPENDIX B

COMPONENTS OF END ITEM LIST

Section I. INTRODUCTION

B-1. Scope

This appendix lists integral components of and basic issue items for the AN/APM-378 to help you inventory items required for safe and efficient operation.

B-2. General

This Components of End Item List is divided into the following sections:

a. Section II. Integral Components of the End Item. Not applicable.

b. Section III. Basic Issue Items. These are the minimum essential items required to place the AN/APM-378 in operation, to operate it, and to perform emergency repairs. Although shipped separately packed they must accompany the during operation and whenever it is transferred between accountable officers. The illustrations will assist you with hard-to-identify items. This manual is your authority to requisition replacement BII, based on TOE/MTOE authorization of the end item.

B-3. Explanation of Columns

a. Illustration. This column is divided as follows :

(1) *Figure number.* Indicates the figure number of the illustration on which the item is shown.

(2) *Item number.* The number used to identify item called out in the illustration.

b. National Stock Number. Indicates the National stock number assigned to the item and which will be used for requisitioning.

c. Description. Indicates the Federal item name and, if required, a minimum description to identify the item. The part number indicates the primary number used by the manufacture, which controls the design and characteristics of the item by means of its engineering drawings, specifications, standards, and inspection requirements to identify an item or range of items. Following the part number, the Federal Supply Code for Manufacturers (FSCM) is shown in parentheses,

d. Location. The physical location of each item listed is given in this column, The lists are designed to inventory all items in one area of the major item before moving on to an adjacent area.

e. Usable on Code. "USABLE ON" codes are included to help you identify which component items are used on the different models. Identification of the codes used in these lists are:

Code

Used On

f. Quantity Required (Qty Reqd). This column lists the quantity of each item required for a complete major item.

g. Quantity. This column is left blank for use, during an inventory. Under the Rcvd column, list the quantity you actually receive on your major item. The Date columns are for your use when you inventory the major item.

(Next printed page is B-2.)

			SECTION III BASIC ISSUE ITEMS					
(1) ILLUSTRATION (A) FIG NO	(2) NATIONAL STOCK NUMBER (B) ITEM NO	(3) DESCRIPTION PART NUMBER	(4) LOCATION (FSCM)	(5) USABLE ON CODE	(6) QTY REQ'D	(7) QUANTITY RCVD DATE		
6-1	2	TEST SET, TRANSPONDER 4035452-050145		EDY	1			
6-2	1	ANTENNA ASSEMBLY 4035456-050145	06845	EDY	1			
6-2	4	CABLE AC POWER 4035453-050145	06845	EDY	1			
6-2	8	CABLE DC POWER 4035549-050145	06845	EDY	1			
6-2	7	SPECIAL PURPOSE CABLE45 4035457-0501	06845	EDY	1			
6-2	5	RF CABLE (25 FEET)4035454-050145	06845	EDY	2			
6-2	6	RF CABLE (6 INCHES) 4035455-050145	06845	EDY	1			
6-2	9	DUMMY CONNECTOR 4075C5168	74868	EDY	1			
6-1	1	COVER, TEST SET 4035451-050145	06845	EDY	1			
6-1	4	CASE ASSEMBLY D10887-278	19178	EDY	1			

APPENDIX C
ADDITIONAL AUTHORIZATION LIST

Section I. INTRODUCTION

C-1. Scope

This appendix lists additional items you are authorized for the support of the Transponder Set, Test Set AN/APM-378.

C-2. General

This list identifies items that do not have to accompany the AN/APM-378 and that do not have to be turned in with it. These items are all authorized to you by CTA, MTOE, TDA, or JTA.

C-3. Explanation of listing

National stock numbers, descriptions, and quantities are provided to help you identify and request

the additional items you require to support this equipment. The items are listed in alphabetical sequence by item name under the type document (i.e., CTA, MTOE, TDA, or JTA) which authorizes the item (s) to you. If the item you require differs between serial numbers of the same model, effective serial numbers are shown in the last line of the description. If item required differs for different models of this equipment, the model is shown under the "Usable cm" heading in the description column. These codes are identified as:

Code

Used On

(Next printed page is C-2.)

TM11-4920-296-14&P SECTION II ADDITIONAL AUTHORIZATION LIST

(1) NATIONAL STOCK NUMBER	(2) DESCRIPTION PART NUMBER AND FSCM	(3) UNIT OF MEAS	(4) QTY AUTH
IRW 4920-01-067- 5397 SF	DIVERSITY ANTENNA, AS-3324/APM-378	EA	

APPENDIX D

MAINTENANCE ALLOCATION

Section I. INTRODUCTION

D-1. General

This appendix provides a summary of the maintenance operations for AN/APM-378. It authorizes categories of maintenance for specific maintenance functions on repairable items and components and the tools and equipment required to perform each function. This appendix may be used as an aid in planning maintenance operations.

D-2. Maintenance Function

Maintenance functions will be limited to and defined as follows:

a. Inspect. To determine the serviceability of an item by comparing its physical, mechanical, and/or electrical characteristics with established standards through examination.

b. Test. To verify serviceability and to detect incipient failure by measuring the mechanical or electrical characteristics of an item and comparing those characteristics with prescribed standards.

c. Service. Operations required periodically to keep an item in proper operating condition, i.e., to clean (decontaminate), to preserve to drain, to paint, or to replenish fuel, lubricants, hydraulic fluids, or compressed air supplies.

d. Adjust. To maintain, within prescribed limits, by bringing into proper or exact position, or by setting the operating characteristics to the specified parameters.

e. Align. To adjust specified variable elements of an item to bring about optimum or desired performance.

f. Calibrate. To determine and cause corrections to be made or to be adjusted on instruments or test measuring and diagnostic equipments used in precision measurement. Consists of comparisons of two instruments, one of which is a certified standard of known accuracy, to detect and adjust any discrepancy in the accuracy of the instrument being compared.

g. Install. The act of emplacing, seating, or fixing into position an item, part, module (component or assembly) in a manner to allow the proper functioning of the equipment or system.

h. Replace. The act of substituting a serviceable like type part, subassembly, or module (component or assembly) for an unserviceable counterpart.

i. Repair. The application of maintenance services (inspect, test, service, adjust, align, calibrate, replace) or other maintenance actions (welding, grinding, riveting, straightening, facing, re-machining, or resurfacing) to restore serviceability to an item by correcting specific damage, fault, malfunction or failure in a part, subassembly, module (component or assembly), end item, or system.

j. Overhaul. That maintenance effort (service/action) necessary to restore an item to a completely serviceable/operational condition as prescribed by maintenance standards (i.e., DMWR) in appropriate technical publications. Overhaul is normally the highest degree of maintenance performed by the Army. Overhaul does not normally return an item to like new condition.

k. Rebuild. Consists of those services/actions necessary for the restoration of unserviceable equipment to a like new condition in accordance with original manufacturing standards. Rebuild is the highest degree of materiel maintenance applied to Army equipment. The rebuild operation includes the act of returning to zero those age measurements (hours, miles, etc.) considered in classifying Army equipment/components.

l. Rebuild. Consists of those services/actions necessary for the restoration of unserviceable equipment to a like new condition in accordance with original manufacturing standards. Rebuild is the highest degree of materiel maintenance applied to Army equipment. The rebuild operation includes the act of returning to zero those age measurements (hours, miles, etc.) considered in classifying Army equipment/components.

D-3. Column Entries

a. Column 1, Group Number. Column 1 lists group numbers, the purpose of which is to identify components, assemblies, subassemblies, and modules with the next higher assembly,

b. Column 2, Component/Assembly. Column 2 contains the noun names of components, assemblies, subassemblies, and modules for which maintenance is authorized.

c. Column 3, Maintenance Functions. Column 3

lists the functions to be performed on the item listed in column 2. When items are listed without maintenance functions, it is solely for purpose of having the group numbers in the MAC and RPSTL coincide.

d. Column 4, Maintenance Category. Column 4 specifies, by the listing of a "work time" figure in the appropriate subcolumn (s), the lowest level of maintenance authorized to perform the function listed in column 3. This figure represents the active time required to perform that maintenance function at the indicated category of maintenance. If the number or complexity of the tasks within the listed maintenance function vary at different maintenance categories, appropriate "work time" figures will be shown for each category. The number of task-hours specified by the "work time" figure represents the average time required to restore an item (assembly, subassembly, component, module, end item or system) to a serviceable condition under typical field operating conditions. This time includes preparation time, troubleshooting time, and quality assurance/quality control time in addition to the time required to perform the specific tasks identified for the maintenance functions authorized in the maintenance allocation chart. Subcolumns of column 4 are as follows:

- C—Operator/Crew
- O—Organizational
- F—Direct Support
- H—General Support
- D—Depot

e. Column 5, Tools and Equipment. Column 5 specifies by code, those common tool sets (not individual tools) and special tools, test, and support

equipment required to perform the designated function.

j. Column 6, Remarks. Column 6 contains an alphabetic code which leads to the remark section IV, Remarks, which is pertinent to the item opposite the particular code.

D-4. Tool and Test Equipment Requirements (Sec. III)

a. Tool or Test Equipment Reference Code. The numbers in this column coincide with the numbers used in the tools and equipment column of the MAC. The numbers indicate the applicable tool or test equipment for the maintenance functions.

b. Maintenance Category. The codes in this column indicate the maintenance category allocated the tool or test equipment.

c. Nomenclature. This column lists the noun name and nomenclature of the tools and test equipment required to perform the maintenance functions.

d. National/NATO Stock Number. This column lists the National/NATO stock number of the specific tool or test equipment.

e. Tool Number. This column lists the manufacturer's part number of the tool followed by the Federal Supply Code for manufacturers (5-digit) in parentheses.

D-5. Remarks (Sec. IV)

a. Reference Code. This code refers to the appropriate item in section II, column 6.

b. Remarks. This column provides the required explanatory information necessary to clarify items appearing in section II.

(Next printed page is D-3.)

SECTION II MAINTENANCE ALLOCATION CHART
FOR AN/APM-378

TM 11-4920-296-14&P

(1) GROUP NUMBER	(2) COMPONENT/ASSEMBLY	(3) MAINTENANCE FUNCTION	(4) MAINTENANCE CATEGORY					(5) TOOLS AND EQPT.	(6) REMARKS
			C	O	F	H	D		
00	TRANSPONDER SET TEST SET AN/ APM-378	Inspect		.1				1	A
		Test		.2				4, 10, 12	
		Test			.5			2	
		Replace		.3				11	
		Repair			1.0			9, 10, 12	
		Adjust			.5			B	
01	RF MODULE ASSY (4035544-0501)	Inspect		.1				3-8	C
		Test		.5				11	
		Replace		.3				11	
		Repair		.5				11	
02	CHASSIS ASSY (4035547-0501)	Inspect		.1				3	D
		Test		.2				11	
		Repair		.5					
03	FRONT PANEL ASSY (4035546-0501)	Inspect		.1				3	
		Test		.2				11	
		Repair		.5					
04	AC POWER CABLE ASSY (W1) (4035453-0501)	Inspect		.1				3	
		Test		.2				11	
		Repair		.5					
05	DC POWER CABLE ASSY (W2) (4035549-0501)	Inspect		.1				3	
		Test		.2				11	
		Repair		.5					
06	COVER, TEST SET (4035451-0501)	Inspect		.1				11	
		Repair		.3					
07	CABLE ASSY, SPECIAL PURPOSE (W3) (4035457-0501)	Inspect		.1				3	
		Test		.2				11	
		Repair		.5					
08	CABLE ASSY, RF (W4) (4035454-0501)	Inspect			.1			3	
		Test			.2			11	
		Repair			.5				
09	CABLE ASSY, RF (W5) (4035455-0501)	Inspect			.1			3	
		Test			.2			11	
		Repair			.5				

SECTION III TOOL AND TEST EQUIPMENT REQUIREMENTS
FOR AN/APM-378

TOOL OR TEST EQUIPMENT REF CODE	MAINTENANCE CATEGORY	NOMENCLATURE	NATIONAL/NATO STOCK NUMBER	TOOL NUMBER
1	0	MULTIMETER AN/URM-105C	6625-00-999-6282	
2	0	TOOL KIT, ELECTRONIC EQUIP TK-101/G	5180-00-064-5178	
3	F	MULTIMETER AN/USM-223	6625-00-999-7465	
4	F	ATTENUATOR, FIXED COAXIAL 6DB (WEINSCHEL 2-6)	6625-00-017-1277	
5	F	VOLTMETER, DIGITAL AN/GSM-64B	6625-00-022-7894	
6	F	COUNTER, ELECTRONIC DIGITAL READOUT TS-1225(V)/U	6625-00-498-8946	
7	F	OSCILLOSCOPE AN/USM-281A	6625-00-228-2201	
8	F	TEST SET, RADIO FREQUENCY POWER AN/USM-161	6625-00-892-5541	
9	F	RADAR TEST SET AN/TPM-25A	6625-00-045-9988	
10	F	PULSE GENERATOR AN/UPM-15A	6625-00-682-2581	
11	F	TOOL KIT, ELECTRONIC EQUIP TK-105/G	5180-00-610-8177	
12	F	CIRCULATOR M3B-1030 (96341)		

REFERENCE CODE	REMARKS
A B C D	OPERATIONAL TEST REPLACE DECODER, INTERROGATOR, SYNCHRONIZER, EVALUATOR MODULES REPLACE TRANSMITTER, MICRO STRIP AND IF VIDEO MODULES REPLACE CHASSIS MOUNTED PARTS. IF TD-1225(V)1/U NOT AVAILABLE USE AN/USM-207A AND CM-77/U

APPENDIX E

REPAIR PARTS LIST

Section I. INTRODUCTION

E-1. Scope

This appendix lists spares and repair parts; special tools, special test, measurement, and diagnostic equipment (TMDE), and other special support equipment required for performance of direct support maintenance of the AN/APM-378. It authorizes the requisitioning and issue of spares and repair parts as indicated by the source and maintenance codes.

E-2. General

This Repair Parts and Special Tools List is divided into the following sections:

a. Section II. Repair Parts List. A list of spares and repair parts authorized for use in the performance of maintenance. The list also includes parts which must be removed for replacement of the authorized parts.

b. Section III. Special Tools List. Not applicable.

c. Section IV. National Stock Number and Part Number Index. A list, in National item identification number (NIIN) sequence, of all National stock numbers (NSN) appearing in the listings, followed by a list, in alphameric sequence, of all part numbers appearing in the listings. National stock numbers and part number are cross-referenced to each illustration figure and item number appearance.

E-3. Explanation of Columns

a. Illustration. This column is divided as follows :

(1) *Figure number.* Indicates the figure number of the illustration on which the item is shown.

(2) *Item number.* The number used to identify item called out in the illustration.

b. Source, Maintenance, and Recwerability (SMR) Codes.

(1) *Source code.* Source codes indicate the manner, of acquiring support items for maintenance, repair, or overhaul of end item, Source

codes are entered in the first and second positions of the Uniform SMR Code format as follows:

<i>Code</i>	<i>Definition</i>
PA	Item procured and stocked for anticipated or known usage.
XD	A support item that is not stocked. When required, item will be procured through normal supply channels.

NOTE

Cannibalization or salvage may be used as a source of supply for any items source coded above except those coded XA and aircraft support items as restricted by AR 700-42.

(2) *Maintenance code.* Maintenance codes are assigned to indicate the levels of maintenance authorized to USE and REPAIR support items. The maintenance codes are entered in the third and fourth positions of the Uniform SMR Code format as follows:

(a) The maintenance code entered in the third position will indicate the lowest maintenance level authorized to remove, replace, and use the support item. The maintenance code entered in the third position will indicate one of the following levels of maintenance:

<i>Code</i>	<i>Application./Explanation</i>
F	Support item is removed, replaced, used at the direct support level.

(b) The maintenance code entered in the fourth position indicates whether the item is to be repaired and identifies the lowest maintenance level with the capability to perform complete repair (i.e., all authorized maintenance functions). This position will contain one of the following maintenance codes:

<i>Code</i>	<i>Application./Explanation</i>
F	The lowest maintenance level capable of complete repair of the support item is the" direct support level.
Z	Nonreparable. No repair is authorized.

(3) *Recoverability code.* Recoverability codes are assigned to support items to indicate the disposition action on unserviceable items. The recoverability code is entered in the fifth position of the Uniform SMR Code format as follows:

Recoverability codes

Definition

Z—Nonreparable item. When unserviceable, condemn and dispose at the level indicated in position 3.

F—Reparable item. When uneconomically reparable, condemn and dispose at the direct support level.

A—Item requires special handling or condemnation procedures because of specific reasons (i.e., precious metal content, high dollar value, critical material or hazardous material). Refer to appropriate manuals/directives for specific instructions.

c. National Stock Number. Indicates the National stock number assigned to the item and will be used for requisitioning purposes.

d. Part Number. Indicates the primary number used by the manufacturer (individual, company, firm, corporation, or Government activity), which controls the design and characteristics of the item by "means of its engineering drawings, specifications, standards, and inspection requirements to identify 'an item or range of items.

NOTE

When a stock numbered item is requisitioned, the repair part received may have a different part number than the part being replaced.

e. Federal Supply Code for Manufacturer (FSCM). The FSCM is a 5-digit numeric code listed in SB 708-42 which is used to identify the manufacturer, distributor, or Government agency, etc.

f. Description. Indicates the Federal item name and, if required, a minimum description to identify the item.

g. Unit of Measure (U/M). Indicates the standard of the basic quantity of the listed item as used in performing the actual maintenance function.

This measure is expressed by a two-character alphabetical abbreviation (e.g., ea, in pr, etc.). When the unit of measure differs from the unit of issue, the lowest unit of issue that will satisfy the required units of measure will be requisitioned.

h. Quantity Incorporated in Unit. Indicates the quantity of the item used in the equipment.

E-4. Special Information

National stock numbers (NSN's) that are missing from P source coded items have been applied for and will be added to this TM by future change revision when they are entered in the Army Master Data File (AMDF). Until the NSN's are established and published, submit exception requisitions to: Commander, US Army Communications and Electronics Materiel Readiness Command, ATTN: DRSEL-MM, Fort Monmouth, NJ 07703 for the part required to support your equipment.

E-5. How to Locate Repair Parts

a. When National stock number or part number is unknown.

(1) *First.* Find the illustration covering the functional group to which the item belongs.

(2) *Second.* Identify the item on the illustration and note the illustration figure and item number of the item.

(3) *Third.* Using the Repair Parts Listing find the figure and item number noted on the illustration.

b. When National stock number or part number is known.

(1) *First.* Using the Index of National Stock Numbers and Part Numbers, find the pertinent National stock number or part number. This index is in NIIN sequence followed by a list of part numbers in alphameric sequence, cross-referenced to the illustration figure number and item number.

(2) *Second.* After finding the figure and item number, locate the figure and item number in the repair parts list.

E-6. Abbreviations

Not applicable.

(Next printed page is E-5.)

SECTION II (1) ILLUSTRATION (A) FIG NO		(2) ITEM NO	(3) NATIONAL STOCK NUMBER	(4) PART NUMBER	(5) FSCM	TM11-4920-296-14&P (6) DESCRIPTION	(7) USABLE ON CODE	(8) QTY INC IN UNIT
TRANSPONDER SET AN/APM-378								
6-1	1	XDFFF		4035451-0501	06845	COVER,TEST SET	EA	1
6-1	2	XDFFF		4035452-0501	06845	TEST SET TRANSP	EA	1
6-1	2A	PAFZZ	5306-00-180-1934	AN3C24A	88044	BOLT,MACHINE	EA	4
6-1	2B	PAFZZ	5330-00-947-4271	NAS1598C3Y	80205	PACKING WITH RETAIN	EA	4
6-1	2C	PAFZZ	5310-00-883-9384	MS15795-842	96906	WASHER,FLAT	EA	4
6-1	2D	XDFZZ		RNF 100-1-4	08795	INSULATION	EA	1
6-1	3	XDFZZ		10-04-2737-1250	18565	GASKET, RF	EA	1
6-1	4	XDFZZ		D10887-2	19178	CASE ASSY	EA	1
6-2	1	XDFFF		4035456-0501	06845	ANTENNA ASSEMBLY	EA	1
6-2	2	XDFZZ		4035507-0001	06845	BRACKET	EA	1
6-2	2A	PAFZZ	5305-00-066-7328	MS24693C27	96906	SCREW,MACHINE	EA	3
6-2	2B	PAFZZ	5310-00-934-9761	MS35649-264	96906	NUT,PLAIN,HEXAGON	EA	3
6-2	2C	PAFZZ	5310-00-929-6395	MS35338-136	96906	WASHER,LOCK	EA	3
6-2	2D	PAFZZ	5310-00-880-5976	MS15795-806	96906	WASHER,FLAT	EA	3
6-2	3	PAFZZ	6625-00-367-4291	15001800	82152	ANTENNA	EA	1
6-2	4	XDFFF		4035453-0501	06845	CABLE ASSEMBLY	EA	1
6-2	5	XDFFF		4035454-0501	06845	CABLE ASSY,RF	EA	2
6-2	5A	PAFZZ	5935-00-835-0508	M39012-16-0001	96906	CONNECTOR,PLUG,ELEC	EA	2
6-2	5B	PAFZZ	6145-00-681-7849	RG223U	80058	CABLE,RADIO FREQUEN	EA	1
6-2	6	XDFFF		4035455-0501	06845	CABLE ASSY,RF	EA	1
6-2	6A	PAFZZ	5935-00-085-7530	58-007-0000	98291	CONNECTOR,PLUG,ELEC	EA	2
6-2	6B	PAFZZ	6145-00-918-9494	RG316U	80058	CABLE,RADIO FREQUEN	EA	1
6-2	6C	XDFZZ		2075059-0005	06845	MARKER,CABLE	EA	1
6-2	7	PAFZZ	6625-00-358-3250	4035457-0501	06845	CABLE ASSEMBLY,SPEC	EA	1
6-2	8	XDFFF		4035549-0501	06845	CABLE ASSY PWR	EA	1
6-2	9	PAFZZ		4075C51	74868	DUMMY CONNECTOR	EA	1
6-2	10	XDFZZ		2075057-0701	06845	INSTRUCTION PLATE	EA	1
6-2	11	XDFZZ		2075058-0701	06845	DECAL EQUIP LIST	EA	1
6-2	12	XDFZZ		4019510-0702	06845	COVER	EA	1
6-3	1	PAFFA	6625-01-088-2693	4035544-0501	06845	MODULE ASSEMBLY	EA	1
6-3	1A	PAFZZ		4035493-0001	06845	SCREW,CAPTIVE	EA	1
6-3	1B	PAFZZ	5365-00-550-5937	MS16632-4025	96906	RING,RETAINING	EA	4
6-3	2	PAFZZ	6625-00-367-4282	4035471-0701	06845	DECODER,PULSE	EA	1
6-3	3	PAFZZ	6625-00-358-3032	4035522-0701	06845	INTERROGATOR	EA	1
6-3	4	PAFZZ	6625-00-367-4290	4035523-0701	06845	SYNCHRONIZER,ELECTR	EA	1
6-3	5	PAFZZ	6625-00-361-2620	4035524-0701	06845	EVALUATOR	EA	1
6-3	6	XDFFF		4035547-0501	06845	CHASSIS ASSY	EA	1
6-3	6A	PAFZZ	5305-00-054-6667	MS51957-42	96906	SCREW,MACHINE	EA	8
6-3	7	XDFFF		4035546-0501	06845	FRONT PANEL ASSY	EA	1

SECTION II (1) ILLUSTRATION		(2)	(3)	(4)	(5)	TM11-4920-296-14&P (6)	(7)	(8)
(A) FIG NO	(B) ITEM NO	SMR CODE	NATIONAL STOCK NUMBER	PART NUMBER	FSCM	DESCRIPTION	USABLE ON CODE	U/M INC IN UNIT
6-4	1	PAFZZ	5935-00-539-2659	MS3106A14S5S	96906	CONNECTOR, PLUG, ELEC		EA
6-4	2	PAFZZ	5935-00-843-7362	UP131M	81349	CONNECTOR, PLUG, ELEC		EA
6-4	3	PAFZZ	5935-00-280-2195	MS3057-6A	96906	ADAPTER, CABLE CLAMP		EA 1
6-4	4	XDFZZ	5365-00-820-4535	MS3420-6	96906	BUSHING, RUBBER		EA 1
6-4	5	XDFZZ		CO-03LGF318-0260	81349	CABLE		EA 1
6-4	6	XDFZZ		2075059-0006	06845	MARKER, CABLE		EA
6-4	7	XDFZZ		2075059-0007	06845	MARKER, CABLE		EA
6-4	8	XDFZZ		2075059-0001	06845	MARKER, CABLE		EA
6-4	9	XDFZZ	5940-00-813-0698	MS25036-101	96906	TERMINAL, LUG		EA 1
6-5	1	PAFZZ	5935-00-539-2659	MS3106A14S5S	96906	CONNECTOR, PLUG, ELEC		EA 1
6-5	2	PAFZZ	5935-00-060-6320	MS3107A16-11P	96906	CONNECTOR, PLUG, ELEC		EA 1
6-5	3	PAFZZ	5935-00-280-2195	MS3057-6A	96906	ADAPTER, CABLE CLAMP		EA 1
6-5	4	PAFZZ	5935-00-688-4026	MS3057-8A	96906	CLAMP, CABLE, ELECTRI		EA 1
6-5	5	XDFZZ		CO-02LLF2180250	81349	CABLE		EA 1
6-5	6	XDFZZ		2075059-0009	06845	MARKER, CABLE		EA 1
6-5	7	XDFZZ		2075059-0002	06845	MARKER, CABLE		EA 1
6-5	8	XDFZZ		2075059-0008	06845	MARKER, CABLE		EA 1
6-5	9	XDFZZ	5365-00-820-4535	MS3420-6	96906	BUSHING, RUBBER		EA 2
6-5	10	XDFZZ	5935-00-936-7377	MS3420-8	96906	BUSHING, ELECTRICAL		EA 1
6-6	1	PAFZZ	5935-00-825-8864	MS3112E18-32S	96906	CONNECTOR, RECEPTACL		EA 1
6-6	2	PAFZZ	5935-00-813-4722	MS3102E14S5P	96906	CONNECTOR, RECEPTACL		EA 1
6-6	2A	PAFZZ	5305-00-054-5651	MS51957-17	96906	SCREW, MACHINE		EA 2
6-6	2B	PAFZZ	5305-00-054-5650	MS51957-16	96906	SCREW, MACHINE		EA 6
6-6	2C	PAFZZ	5970-00-882-7876	NAS1515H04	80205	INSULATOR, WASHER		EA 8
6-6	2D	PAFZZ	5310-00-687-6058	22NKTM40	72962	NUT, SELF-LOCKING, CA		EA 8
6-6	3	XDFZZ		4042881-0501	06845	CHASSIS, RFI, FILTER		EA
6-6	4	XDFZZ		4042883-0701	06845	SHIELD, RFI, FILTER		EA
6-6	5	XDFZZ		4042882-0001	06845	COVER, RFI, FILTER		EA
6-6	5A	PAFZZ	5305-00-054-6652	MS51957-28	96906	SCREW, MACHINE		EA 4
6-6	5B	PAFZZ	5310-00-782-1349	MS15795-804	96906	WASHER, FLAT		EA 8
6-6	6	XDFZZ	5330-00-292-3120	10-40450-18S	77820	GASKET		EA 1
6-6	7	XDFZZ		10-40450-14S	77820	GASKET		EA 1
6-6	8	PAFZZ		MS3118-18C	96906	CONNECTOR		EA 1
6-6	9	PAFZZ	5935-00-137-4669	MS25043-14D	96906	COVER, ELECTRICAL CO		EA 1
6-6	10	XDFZZ		2075079-0501	06845	CABLE ASSY		EA 1
6-6	11	PAFZZ	5925-00-836-6173	M39019-1-31	81349	CIRCUIT BREAKER		EA 1
6-6	12	PAFZZ		M39019-3-27	81349	CIRCUIT BREAKER		EA 1
6-6	13	PAFZZ		2808BALBESP	91812	SWITCH PUSHBUTTON		EA 4
6-6	13A	PAFZZ	5305-00-764-2966	MS51959-2	96906	SCREW, MACHINE		EA 8
6-6	14	PAFZZ	5930-00-683-1626	MS24523-30	96906	SWITCH, TOGGLE		EA 1

SECTION II		TM11-4920-296-14&P						
(1)	(2)	(3)	(4)	(5)	(6)	(7)	(8)	
ILLUSTRATION					DESCRIPTION	USABLE ON CODE	QTY INC IN UNIT	
(A)	(B)	NATIONAL	PART	FSCM		U/M		
FIG	ITEM	STOCK	NUMBER					
NO	NO	NUMBER	NUMBER					
6-6	14A	PAFZZ 5330-00-806-8769	MS25196-1	96906	PACKING WITH RETAIN	EA	1	
6-6	15	PAFZZ 5930-00-683-1625	MS24523-31	96906	SWITCH,TOGGLE	EA	1	
6-6	15A	PAFZZ 5330-00-806-8769	MS25196-1	96906	PACKING WITH RETAIN	EA	1	
6-6	16	PAFZZ	4019391-0701	06845	SWITCH ROTARY	EA	3	
6-6	17	AFZZ 5930-00-683-1629	MS24523-23	96906	SWITCH,TOGGLE	EA	2	
6-6	17A	PAFZZ 5330-00-806-8769	MS25196-1	96906	PACKING WITH RETAIN	EA	2	
6-6	18	PAFZZ 6210-00-176-4928	LH89-1	81349	LIGHT,INDICATOR	EA	2	
6-6	19	PAFZZ 6240-00-851-4352	330	08806	LAMP,INCANDESCENT	EA	2	
6-6	20	PAFZZ 6210-00-183-0513	LC35YT2	81349	LENS,LIGHT	EA	1	
6-6	21	PAFZZ 6210-00-176-4954	LC35RT2	81349	LENS,LIGHT	EA	1	
6-6	22	PAFZZ	VM300S101	87034	LAMPHOLDER	EA	1	
6-6	23	PAFZZ	VM300S102	87034	LAMPHOLDER	EA	1	
6-6	24	PAFZZ 6240-00-941-8488	756	08806	LAMP,INCANDESCENT	EA	2	
6-6	25	XDFZZ	10509A1032-2	06540	HANDLE	EA	2	
6-6	25A	PAFZZ 5330-00-947-4271	NAS1598C3Y	80205	PACKING WITH RETAIN	EA	4	
6-6	25B	PAFZZ 5305-00-059-3661	MS51958-65	96906	SCREW,MACHINE	EA	4	
6-6	25C	PAFZZ 5310-00-883-9384	MS15795-842	96906	WASHER,FLAT	EA	4	
6-6	25D	PAFZZ 5310-00-933-8120	MS35338-138	96906	WASHER,LOCK	EA	4	
6-6	26	PAFZZ 5355-00-556-0145	MS91528-1K2B	96906	KNOB	EA	3	
6-6	27	PAFZZ	1200-074	12294	FILTER	EA	2	
6-6	28	PAFZZ 5915-01-024-3429	9000-100-0037	72982	FILTER,RADIO FREQUE	EA	2	
6-6	29	PAFZZ 5940-00-939-7825	SE26XF03	81349	TERMINAL,STUD	EA	2	
6-6	29A	PAFZZ 5305-00-054-6656	MS51957-32	96906	SCREW,MACHINE	EA	1	
6-6	29B	PAFZZ 5310-00-929-6395	MS35338-136	96906	WASHER,LOCK	EA	1	
6-6	30	XDFZZ	4035496-0501	06845	BLOCK MOUNTING	EA	1	
6-6	30A	PAFZZ 5305-00-520-5568	MS3212-12	96906	SCREW PAN HEAD	EA	2	
6-6	31	XDFZZ	4035495-0001	06845	BLOCK,MOUNTING	EA	1	
6-6	31A	PAFZZ 5305-00-520-5568	MS3212-12	96906	SCREW PAN HEAD	EA	2	
6-6	32	XDFZZ	4019513-0001	06845	SHAFT	EA	1	
6-6	33	XDFZZ	4019514-0001	06845	SPACER SLEEVE	EA	1	
6-6	34	XDFZZ	4035458-0001	06845	LEVER OPERATING	EA	1	
6-6	34A	PAFZZ	AN565D632H2	96906	SETSCREW	EA	2	
6-6	35	XDFZZ	4035460-0501	06845	SPACER THREADED	EA	2	
6-6	36	XDFZZ	4035504-0701	06845	PLATE ID	EA	1	
6-6	37	XDFZZ	4035505-0701	06845	PLATE SERIAL NO	EA	1	
6-6	38	XDFZZ	4042888-0001	06845	PLATE CAUTION	EA	1	
6-6	39	PAFZZ 5340-00-989-9224	MS25281R6	96906	CLAMP,LOOP	EA	1	
6-6	39A	PAFZZ 5305-00-054-6668	MS51957-43	96906	SCREW,MACHINE	EA	1	
6-6	39B	PAFZZ 5310-00-225-5328	MS15795-841	96906	WASHER,FLAT	EA	1	
6-6	39C	PAFZZ 5310-00-933-8119	MS35338-137	96906	WASHER,LOCK	EA	1	

SECTION II (1) ILLUSTRATION		(2)	(3)	(4)	(5)	TM11-4920-296-14&P (6)	(7)	(8)
(A) FIG NO	(B) ITEM NO	SMR CODE	NATIONAL STOCK NUMBER	PART NUMBER	FSCM	DESCRIPTION	USABLE ON CODE	U/M INC IN UNIT
6-6	40	PAFZZ	5340-00-543-3931	MS25281R3	96906	CLAMP, LOOP		EA
6-6	40A	PAFZZ	5305-00-054-6668	MS51957-43	96906	SCREW, MACHINE		EA
6-6	40B	PAFZZ	5310-00-225-5328	MS15795-841	96906	WASHER, FLAT		EA 1
6-6	40C	PAFZZ	5310-00-933-8119	MS35338-137	96906	WASHER, LOCK		EA 1
6-6	41	PAFZZ	5940-00-827-2653	MS77068-2	96906	TERMINAL, LUG		EA 1
6-6	41A	PAFZZ	5305-00-054-6650	MS51957-26	96906	SCREW, MACHINE		EA
6-6	42	XDFFF		2075079-0502	06845	CABLE ASSY		EA
6-6	43	XDFFF		2075079-0503	06845	CABLE ASSY		EA
6-6	44	XDFZZ	5975-00-727-5153	MS3367-4-9	96906	STRAP, TIEDOWN, ELECT		EA 2
6-6	45	XDFZZ		2075056-0501	06845	WIRING HARNESS		EA 1
6-6	46	PAFZZ	5940-00-813-0698	MS25036-101	96906	TERMINAL, LUG		EA 12
6-6	47	PAFZZ	5975-00-727-5153	MS3367-4-9	96906	STRAP, TIEDOWN, ELECT		EA 80
6-6	48	PAFZZ	5306-00-180-1934	AN3C24A	88044	BOLT, MACHINE		EA 4
6-6	49	PAFZZ	5330-00-947-4271	NAS1598C3Y	80205	PACKING WITH RETAIN		EA 4
6-6	50	PAFZZ	5310-00-883-9384	MS15795-842	96906	WASHER, FLAT		EA 4
6-6	51	XDFZZ		RNF 100-1-4	08795	INSULATION SLEEVING		EA 4
6-6	52	PAFZZ	5905-00-114-0710	RCR07G331JS	81349	RESISTOR, FIXED, COMP		EA 1
6-6	53	PAFZZ	5940-00-156-7345	MS77067-2	96906	TERMINAL, LUG		EA 2
6-6	54	XDFZZ		3330-53-1	17117	TERMINAL		EA 1
6-6	55	XDFZZ		2074099-2301	06845	SCREW		EA 1
6-6	56	XDFZZ		4035470-0501	06845	PANEL FRONT		EA 1
6-7	1	PAFZZ	5935-00-563-7126	9950-6	95712	CONNECTION, RECEPTACL		EA 1
6-7	2	PAFZZ	5935-00-401-7584	50-028-0000	98291	CONNECTOR, PLUG, ELEC		EA 1
6-7	3	XDFZZ	6145-00-918-9494	RG316U	80058	CABLE, RADIO FREQUEN		EA 1
6-7	4	XDFZZ		2075059-0012	06845	MARKER, CABLE USED ON P/N 2075079-0501		EA 1
6-7	4A	XDFZZ		2075059-0013	06845	MARKER USED ON P/N 2075079-0502		EA
6-7	4B	XDFZZ		2075059-0014	06845	MARKER CABLE USED ON P/N 2075079-0503		EA
6-8	1	XDFZZ		4035450-0501	06845	PRINTED WIRING BD		EA
6-8	1A	PAFZZ	5310-00-929-6395	MS35338-136	96906	WASHER, LOCK		EA 6
6-8	1B	PAFZZ	5310-00-880-5976	MS15795-806	96906	WASHER, FLAT		EA 6
6-8	1C	PAFZZ	5305-00-054-6651	MS51957-27	96906	SCREW, MACHINE		EA 6
6-8	2	XDFZZ		4035474-0001	06845	PIN		EA 4
6-8	3	PAFZZ	5935-00-098-9947	200092-01	16512	CONNECTOR, RECEPTACL		EA 4
6-8	4	PAFZZ	5935-00-986-2226	NCD200147	16512	CONNECTOR, RECEPTACL		EA 1
6-8	5	XDFZZ		4035482-0001	06845	PRINTED WIRING BD		EA 1
6-8	6	XDFZZ		3-00005-114-1	06845	PRINTED CIRCUIT CD		EA 1
6-8	6A	PAFZZ	5305-00-059-3657	MS51958-61	96906	SCREW, MACHINE		EA 4
6-8	6B	PAFZZ	5310-00-933-8120	MS35338-138	96906	WASHER, LOCK		EA 4
6-8	6C	PAFZZ	5310-00-883-9384	MS15795-842	96906	WASHER, FLAT		EA 4
6-8	7	PAFZZ	5950-00-078-7422	H935	80223	TRANSFORMER, POWER		EA 1

SECTION II (1) ILLUSTRATION		(2)	(3)	(4)	(5)	TM11-4920-296-14&P (6)	(7)	(8)
(A) FIG NO	(B) ITEM NO	SMR CODE	NATIONAL STOCK NUMBER	PART NUMBER	FSCM	DESCRIPTION	USABLE ON CODE	U/M INC IN UNIT
6-8	7A	PAFZZ	5310-00-934-9761	MS35649-264	96906	NUT, PLAIN, HEXAGON		EA 4
6-8	7B	PAFZZ	5310-00-929-6395	MS35338-136	96906	WASHER, LOCK		EA 4
6-8	7C	PAFZZ	5310-00-880-5976	MS15795-806	96906	WASHER, FLAT		EA 4
6-8	8	PAFZZ	5961-00-124-9046	MDA952-2	04713	RECTIFIER, SEMICONDU		EA 1
6-8	8A	PAFZZ	5305-00-054-5652	MS51957-18	96906	SCREW, MACHINE		EA 2
6-8	8B	PAFZZ	5310-00-933-8118	MS35338-135	96906	WASHER, LOCK		EA 2
6-8	9	PAFZZ		1N5550	81349	SEMICONDUCTOR DEVIC		EA 1
6-8	10	PAFZZ	5905-00-931-7076	RER70F9R09R	81349	RESISTOR, FIXED, WIRE		EA 1
6-8	10A	PAFZZ	5305-00-054-5649	MS51957-15	96906	SCREW, MACHINE		EA 2
6-8	10B	PAFZZ	5310-00-782-1349	MS15795-804	96906	WASHER, FLAT		EA 2
6-8	10C	PAFZZ	5310-00-933-8118	MS35338-135	96906	WASHER, LOCK		EA 2
6-8	10D	PAFZZ	5310-00-934-9748	MS35649-244	96906	NUT, PLAIN, HEXAGON		EA 2
6-8	11	PAFZZ		RER70F12R0M	81349	RESISTOR		EA 1
6-8	11A	PAFZZ	5305-00-054-5649	MS51957-15	96906	SCREW, MACHINE		EA 2
6-8	11B	PAFZZ	5310-00-782-1349	MS15795-804	96906	WASHER, FLAT		EA 2
6-8	11C	PAFZZ	5310-00-933-8118	MS35338-135	96906	WASHER, LOCK		EA 2
6-8	11D	PAFZZ	5310-00-934-9748	MS35649-244	96906	NUT, PLAIN, HEXAGON		EA 2
6-8	12	PAFZZ		M39018-03-0731	81349	CAPACITOR		EA 1
6-8	13	PAFZZ	5962-00-599-8877	7812KM	34148	MICROCIRCUIT, LINEAR		EA 1
6-8	13A	PAFZZ	5305-00-054-6652	MS51957-28	96906	SCREW, MACHINE		EA 2
6-8	13B	PAFZZ	5310-00-209-1366	MS35335-58	96906	WASHER, LOCK		EA 2
6-8	13C	PAFZZ	5310-00-934-9761	MS35649-264	96906	NUT, PLAIN, HEXAGON		EA 2
6-8	14	PAFZZ		7805KM	13715	MICROCIRCUIT, ELECTR		EA 1
6-8	14A	PAFZZ	5305-00-054-6652	MS51957-28	96906	SCREW, MACHINE		EA 2
6-8	14B	PAFZZ	5310-00-209-1366	MS35335-58	96906	WASHER, LOCK		EA 2
6-8	14C	PAFZZ	5310-00-934-9761	MS35649-264	96906	NUT, PLAIN, HEXAGON		EA 2
6-8	15	PAFZZ	5940-00-827-2653	MS77068-2	96906	TERMINAL, LUG		EA 1
6-8	15A	PAFZZ	5305-00-054-6650	MS51957-26	96906	SCREW, MACHINE		EA 1
6-8	15B	PAFZZ	5310-00-934-9761	MS35649-264	96906	NUT, PLAIN, HEXAGON		EA 1
6-8	16	PAFZZ		MS2521R3	96906	CLAMP		EA 2
6-8	16A	PAFZZ	5305-00-054-6670	MS51957-45	96906	SCREW, MACHINE		EA 1
6-8	16B	PAFZZ	5310-00-933-8119	MS35338-137	96906	WASHER, LOCK		EA 1
6-8	16C	PAFZZ	5310-00-934-9759	MS35649-284	96906	NUT, PLAIN, HEXAGON		EA 1
6-8	17	PAFZZ	5340-00-989-9224	MS25281R6	96906	CLAMP, LOOP		EA 1
6-8	17A	PAFZZ	5305-00-054-6670	MS51957-45	96906	SCREW, MACHINE		EA 1
6-8	17B	PAFZZ	5310-00-933-8119	MS35338-137	96906	WASHER, LOCK		EA 1
6-8	17C	PAFZZ	5310-00-934-9759	MS35649-284	96906	NUT, PLAIN, HEXAGON		EA 1
6-8	18	XDFFF		4035503-0501	06845	CHASSIS		EA 1
6-8	19	XDFZZ		4035483-0001	06845	PIN		EA 2
6-8	20	XDFZZ	5940-00-764-6447	SL201-197F	12615	TERMINAL, STUD		EA 2

SECTION II		TM11-4920-296-14&P						
(1)	(2)	(3)	(4)	(5)	(6)	(7)	(8)	
ILLUSTRATION					DESCRIPTION		QTY	
(A)	(B)	NATIONAL	PART	FSCM		USABLE ON CODE	INC	
FIG	ITEM	STOCK	NUMBER				IN	
NO	NO	NUMBER					UNIT	
6-8	21	XDFZZ		100-200-12A31	99378	CLIP	EA	1
6-8	21A	XDFZZ	5320-00-428-0822	MS16535-133N	96906	RIVET, TUBULAR	EA	2
6-8	22	XDFZZ		NCN10-1-2	07886	NUT	EA	4
6-8	23	XDFZZ		NCN10-8-2	07886	NUT	EA	2
6-8	24	XDFZZ	5310-00-570-9160	NCN6-1-2	07886	NUT, PLAIN, CLINCH	EA	2
6-8	25	XDFZZ		016-2000-00-0140	98291	JACK	EA	1
6-8	26	XDFZZ		016-2000-00-0142	98291	JACK	EA	2
6-8	27	XDFZZ		S6241-263F	12615	TERMINAL, STUD	EA	2
6-8	28	XDFZZ	5310-00-150-4041	MS3214-3	96906	NUT, PLAIN, CLINCH	EA	2
6-8	29	XDFZZ		4035459-0001	06845	CHASSIS	EA	1
6-9	1	XDFZZ		4035489-0501	06845	COVER, PROTECTIVE	EA	1
6-9	1A	PAFZZ	5305-00-054-5647	MS51957-13	96906	SCREW, MACHINE	EA	4
6-9	1B	PAFZZ	5310-00-933-8118	MS35338-135	96906	WASHER, LOCK	EA	4
6-9	1C	PAFZZ	5310-00-782-1349	MS15795-804	96906	WASHER, FLAT	EA	4
6-9	2	XDFZZ		4035494-0001	06845	PRINTED WIRING BD	EA	1
6-9	2A	PAFZZ	5305-00-054-5647	MS51957-13	96906	SCREW, MACHINE	EA	4
6-9	2B	PAFZZ	5310-00-782-1349	MS15795-804	96906	WASHER, FLAT	EA	4
6-9	3	PAFZZ	6625-00-358-2023	4035534-0701	06845	CIRCUIT CARD ASSEMB	EA	1
6-9	3A	PAFZZ	5305-00-054-5646	MS51957-12	96906	SCREW, MACHINE	EA	2
6-9	3B	PAFZZ	5310-00-933-8118	MS35338-135	96906	WASHER, LOCK	EA	2
6-9	3C	PAFZZ	5310-00-782-1349	MS15795-804	96906	WASHER, FLAT	EA	2
6-9	4	PAFZZ	6625-00-358-2006	4035535-0701	06845	MICROSTRIP MODULE	EA	1
6-9	4A	PAFZZ	5305-00-054-5646	MS51957-12	96906	SCREW, MACHINE	EA	2
6-9	4B	PAFZZ	5310-00-933-8118	MS35338-135	96906	WASHER, LOCK	EA	2
6-9	4C	PAFZZ	5310-00-782-1349	MS15795-804	96906	WASHER, FLAT	EA	2
6-9	5	PAFZZ	6625-00-358-2035	4035536-0701	06845	CIRCUIT CARD ASSEMB	EA	1
6-9	5A	PAFZZ	5305-00-054-5646	MS51957-12	96906	SCREW, MACHINE	EA	2
6-9	5B	PAFZZ	5310-00-933-8118	MS35338-135	96906	WASHER, LOCK	EA	2
6-9	5C	PAFZZ	5310-00-782-1349	MS15795-804	96906	WASHER, FLAT	EA	2
6-9	6	PAFZZ	5935-00-987-4727	NCD200149	16512	CONNECTOR, RECEPTACL	EA	1
6-9	6A	PAFZZ	5310-00-827-9139	MS51858-2	96906	NUT, PLAIN, HEXAGON	EA	2
6-9	7	PAFZZ	5905-00-111-4845	RCR07G201JS	81349	RESISTOR, FIXED, COMP	EA	1
6-9	8	PAFZZ	5905-00-574-2136	RT22C2X102	81349	RESISTOR, VARIABLE, W	EA	1
6-9	9	PAFZZ	5905-00-141-0678	RT22C2X103	81349	RESISTOR, VARIABLE, W	EA	1
6-9	10	XDFZZ		2075073-0001	06845	CABLE, COAX	EA	1
6-9	11	PAFZZ		4035493-0001	06845	SCREW, CAPTIVE	EA	2
6-9	12	PAFZZ	5365-00-550-5937	MS16632-4025	96906	RING, RETAINING	EA	2
6-9	13	XDFZZ		4035480-0501	06845	HOUSING RF	EA	1
6-10	1	PAFZZ	5999-00-924-1261	S202	18677	EJECTOR, PRINTED CIR	EA	4
6-10	2	XDFZZ	5999-00-924-1261	4035472-0701	06845	EJECTOR, PRINTED CIR USED ON P/N 4035471-0701	EA	1

SECTION II		TM11-4920-296-14&P							
(1)	(2)	(3)	(4)	(5)	(6)		(7)	(8)	
ILLUSTRATION								QTY	
(A)	(B)	NATIONAL			DESCRIPTION		U/M	INC	
FIG	ITEM	STOCK	PART	FSCM		USABLE ON CODE		IN	
NO	NO	NUMBER	NUMBER					UNIT	
6-10	2A	XDFZZ	5999-00-924-1261	4035472-0702	06845	EJECTOR,PRINTED CIR USED ON P/N 4035522-0701	EA	1	
6-10	2B	XDFZZ	5999-00-924-1261	4035472-0703	06845	EJECTOR,PRINTED CIR USED ON P/N 4035523-0701	EA	1	
6-10	2C	XDFZZ	5999-00-924-1261	4035472-0704	06845	EJECTOR,PRINTED CIR USED ON P/N 4035524-0701	EA	1	

STOCK NUMBER	FIGURE NO	ITEM NO	STOCK NUMBER	FIGURE NO	ITEM NO
5305-00-054-5646	6-9	3A	5940-00-764-6447	6-8	20
5305-00-054-5646	6-9	4A	5310-00-782-1349	6-6	5B
5305-00-054-5646	6-9	5A	5310-00-782-1349	6-8	10B
5305-00-054-5647	6-9	1A	5310-00-782-1349	6-8	11B
5305-00-054-5647	6-9	2A	5310-00-782-1349	6-9	1C
5305-00-054-5649	6-8	10A	5310-00-782-1349	6-9	2B
5305-00-054-5649	6-8	11A	5310-00-782-1349	6-9	3C
5305-00-054-5650	6-6	2B	5310-00-782-1349	6-9	4C
5305-00-054-5651	6-6	2A	5310-00-782-1349	6-9	5C
5305-00-054-5652	6-8	8A	5330-00-806-8769	6-6	14A
5305-00-054-6650	6-6	41A	5330-00-806-8769	6-6	15A
5305-00-054-6650	6-8	15A	5330-00-806-8769	6-6	17A
5305-00-054-6651	6-8	1C	5940-00-813-0698	6-4	9
5305-00-054-6652	6-6	5A	5940-00-813-0698	6-6	46
5305-00-054-6652	6-8	13A	5935-00-813-4722	6-6	2
5305-00-054-6652	6-8	14A	5365-00-820-4535	6-4	4
5305-00-054-6656	6-6	29A	5365-00-820-4535	6-5	9
5305-00-054-6667	6-3	6A	5935-00-825-8864	6-6	1
5305-00-054-6668	6-6	39A	5940-00-827-2653	6-6	41
5305-00-054-6668	6-6	40A	5940-00-827-2653	6-8	15
5305-00-054-6670	6-8	16A	5310-00-827-9139	6-9	6A
5305-00-054-6670	6-8	17A	5935-00-835-0508	6-2	5A
5305-00-059-3657	6-8	6A	5925-00-836-6173	6-6	11
5305-00-059-3661	6-6	25B	5935-00-843-7362	6-4	2
5935-00-060-6320	6-5	2	6240-00-851-4352	6-6	19
5305-00-066-7328	6-2	2A	5310-00-880-5976	6-2	2D
5950-00-078-7422	6-8	7	5310-00-880-5976	6-8	1B
5935-00-085-7530	6-2	6A	5310-00-880-5976	6-8	7C
5935-00-098-9947	6-8	3	5970-00-882-7876	6-6	2C
5905-00-111-4845	6-9	7	5310-00-883-9384	6-1	2C
5905-00-114-0710	6-6	52	5310-00-883-9384	6-6	25C
5961-00-124-9046	6-8	8	5310-00-883-9384	6-6	50
5935-00-137-4669	6-6	9	5310-00-883-9384	6-8	6C
5905-00-141-0678	6-9	9	6145-00-918-9494	6-2	6B
5310-00-150-4041	6-8	2B	6145-00-918-9494	6-7	3
5940-00-156-7345	6-6	53	5999-00-924-1261	6-1	1
6210-00-176-4928	6-6	18	5999-00-924-1261	6-10	2
6210-00-176-4954	6-6	21	5999-00-924-1261	6-10	2
5306-00-180-1934	6-1	2A	5999-00-924-1261	6-10	2B
5306-00-180-1934	6-6	48	5999-00-924-1261	6-10	2C
6210-00-183-0513	6-6	20	5310-00-929-6395	6-2	2C
5310-00-209-1366	6-8	13B	5310-00-929-6395	6-6	29B
5310-00-209-1366	6-8	14B	5310-00-929-6395	6-8	1A
5310-00-225-5328	6-6	39B	5310-00-929-6395	6-8	7B
5310-00-225-5328	6-6	40B	5905-00-931-7076	6-8	10
5935-00-280-2195	6-4	3	5310-00-933-8118	6-8	8B
5935-00-280-2195	6-5	3	5310-00-933-8118	6-8	10C
5330-00-292-3120	6-6	6	5310-00-933-8118	6-8	11C
6625-00-358-2006	6-9	4	5310-00-933-8118	6-9	1B
6625-00-358-2023	6-9	3	5310-00-933-8118	6-9	3B
6625-00-358-2035	6-9	5	5310-00-933-8118	6-9	4B
6625-00-358-3032	6-3	3	5310-00-933-8118	6-9	5B
6625-00-358-3250	6-2	7	5310-00-933-8119	6-6	39C
6625-00-361-2620	6-3	5	5310-00-933-8119	6-6	40C
6625-00-367-4282	6-3	2	5310-00-933-8119	6-8	16B
6625-00-367-4290	6-3	4	5310-00-933-8119	6-8	17B
6625-00-367-4291	6-2	3	5310-00-933-8120	6-6	25D
5935-00-401-7584	6-7	2	5310-00-933-8120	6-8	6B
5320-00-428-0822	6-8	21A	5310-00-934-9748	6-8	10D
5305-00-520-5568	6-6	30A	5310-00-934-9748	6-8	11D
5305-00-520-5568	6-6	31A	5310-00-934-9759	6-8	16C
5935-00-539-2659	6-4	1	5310-00-934-9759	6-8	17C
5935-00-539-2659	6-5	1	5310-00-934-9761	6-2	2B
5340-00-543-3931	6-6	40	5310-00-934-9761	6-8	7A
5365-00-550-5937	6-3	1B	5310-00-934-9761	6-8	13C
5365-00-550-5937	6-9	12	5310-00-934-9761	6-8	14C
5355-00-556-0145	6-6	26	5310-00-934-9761	6-8	15B
5935-00-563-7126	6-7	1		6-5	10
5310-00-570-9160	6-8	24	5940-00-939-7825	6-6	29
5905-00-574-2136	6-9	8	6240-00-941-8488	6-6	24
5962-00-599-8877	6-8	13	5330-00-947-4271	6-1	2B
6145-00-681-7849	6-2	5B	5330-00-947-4271	6-6	25A
5930-00-683-1625	6-6	15	5330-00-947-4271	6-6	49
5930-00-683-1626	6-6	14	5935-00-986-2226	6-8	4
5930-00-683-1629	6-6	17	5935-00-987-4727	6-9	6
5310-00-687-6058	6-6	2D	5340-00-989-9224	6-6	39
5935-00-688-4026	6-5	4	5340-00-989-9224	6-8	17
5975-00-727-5153	6-6	44	5915-01-024-3429	6-6	28
5975-00-727-5153	6-6	47	6625-01-088-2693	6-3	1
5305-00-764-2966	6-6	13A			

PART NUMBER	FSCM	FIG NO	ITEM NO	PART NUMBER	FSCM	FIG NO	ITEM NO
AN3C24A	88044	6-1	2A	MS35338-138	96906	6-8	6B
AN3C24A	88044	6-6	48	MS35649-244	96906	6-8	10D
AN565D632H2	96906	6-6	34A	MS35649-244	96906	6-8	11D
CO-02LLF2180250	81349	6-5	5	MS35649-264	96906	6-2	2B
CO-03LGF318-0260	81349	6-4	5	MS35649-264	96906	6-8	7A
D10887-2	19178	6-1	4	MS35649-264	96906	6-8	13C
H935	80223	6-8	7	MS35649-264	96906	6-8	14C
LC35RT2	81349	6-6	21	MS35649-264	96906	6-8	15B
LC35YT2	81349	6-6	20	MS35649-284	96906	6-8	16C
LH89-1	81349	6-6	18	MS35649-284	96906	6-8	17C
MDA952-2	04713	6-8	8	MS51858-2	96906	6-9	6A
MS15795-804	96906	6-6	5B	MS51957-12	96906	6-9	3A
MS15795-804	96906	6-8	10B	MS51957-12	96906	6-9	4A
MS15795-804	96906	6-8	11B	MS51957-12	96906	6-9	5A
MS15795-804	96906	6-9	1C	MS51957-13	96906	6-9	1A
MS15795-804	96906	6-9	2B	MS51957-13	96906	6-9	2A
MS15795-804	96906	6-9	3C	MS51957-15	96906	6-8	10A
MS15795-804	96906	6-9	4C	MS51957-15	96906	6-8	11A
MS15795-804	96906	6-9	5C	MS51957-16	96906	6-6	2B
MS15795-806	96906	6-2	2D	MS51957-17	96906	6-6	2A
MS15795-806	96906	6-8	1B	MS51957-18	96906	6-8	8A
MS15795-806	96906	6-8	7C	MS51957-26	96906	6-6	41A
MS15795-841	96906	6-6	39B	MS51957-26	96906	6-8	15A
MS15795-841	96906	6-6	40B	MS51957-27	96906	6-8	1C
MS15795-842	96906	6-1	2C	MS51957-28	96906	6-6	5A
MS15795-842	96906	6-6	25C	MS51957-28	96906	6-8	13A
MS15795-842	96906	6-6	50	MS51957-28	96906	6-8	14A
MS15795-842	96906	6-8	6C	MS51957-32	96906	6-6	29A
MS16535-133N	96906	6-8	21A	MS51957-42	96906	6-3	6A
MS16632-4025	96906	6-3	1B	MS51957-43	96906	6-6	39A
MS16632-4025	96906	6-9	12	MS51957-43	96906	6-6	40A
MS24523-23	96906	6-6	17	MS51957-45	96906	6-8	16A
MS24523-30	96906	6-6	14	MS51957-45	96906	6-8	17A
MS24523-31	96906	6-6	15	MS51958-61	96906	6-8	6A
MS24693C27	96906	6-2	2A	MS51958-65	96906	6-6	25B
MS25036-101	96906	6-4	9	MS51959-2	96906	6-6	13A
MS25036-101	96906	6-6	46	MS77067-2	96906	6-6	53
MS25043-14D	96906	6-6	9	MS77068-2	96906	6-6	41
MS25196-1	96906	6-6	14A	MS77068-2	96906	6-8	15
MS25196-1	96906	6-6	15A	MS91528-1K2B	96906	6-6	26
MS25196-1	96906	6-6	17A	M39012-16-0001	96906	6-2	5A
MS2521R3	96906	6-8	16	M39018-03-0731	81349	6-8	12
MS25281R3	96906	6-6	40	M39019-1-31	81349	6-6	11
MS25281R6	96906	6-6	39	M39019-3-27	81349	6-6	12
MS25281R6	96906	6-8	17	NAS1515H04	80205	6-6	2C
MS3057-6A	96906	6-4	3	NAS1598C3Y	80205	6-1	2B
MS3057-6A	96906	6-5	3	NAS1598C3Y	80205	6-6	25A
MS3057-8A	96906	6-5	4	NAS1598C3Y	80205	6-6	49
MS3102E14S5P	96906	6-6	2	NCD200147	16512	6-8	4
MS3106A14S5S	96906	6-4	1	NCD200149	16512	6-9	6
MS3106A14S5S	96906	6-5	1	NCN10-1-2	07886	6-8	22
MS3107A16-11P	96906	6-5	2	NCN10-8-2	07886	6-8	23
MS3112E18-32S	96906	6-6	1	NCN6-1-2	07886	6-8	24
MS3118-18C	96906	6-6	8	RCR07G201JS	81349	6-9	7
MS3212-12	96906	6-6	30A	RCR07G331JS	81349	6-6	52
MS3212-12	96906	6-6	31A	RER70F12ROM	81349	6-8	11
MS3214-3	96906	6-8	28	RER70F9R09R	81349	6-8	10
MS3367-4-9	96906	6-6	44	RG223U	80058	6-2	5B
MS3367-4-9	96906	6-6	47	RG316U	80058	6-2	6B
MS3420-6	96906	6-4	4	RG316U	80058	6-7	3
MS3420-6	96906	6-5	9	RNF100-1-4	08795	6-1	2D
MS3420-8	96906	6-5	10	RNF100-1-4	08795	6-6	51
MS35335-58	96906	6-8	13B	RT22C2X102	81349	6-9	8
MS35335-58	96906	6-8	14B	RT22C2X103	81349	6-9	9
MS35338-135	96906	6-8	8B	SE26XF03	81349	6-6	29
MS35338-135	96906	6-8	10C	SL201-197F	12615	6-8	20
MS35338-135	96906	6-8	11C	S202	18677	6-1	1
MS35338-135	96906	6-9	1B	S6241-263F	12615	6-8	27
MS35338-135	96906	6-9	3B	UPL131M	81349	6-4	2
MS35338-135	96906	6-9	4B	VM300S101	87034	6-6	22
MS35338-135	96906	6-9	5B	VM300S102	87034	6-6	23
MS35338-136	96906	6-2	2C	016-2000-00-0140	98291	6-8	25
MS35338-136	96906	6-6	29B	016-2000-00-0142	98291	6-8	26
MS35338-136	96906	6-8	1A	1N5550	81349	6-8	9
MS35338-136	96906	6-8	7B	10-04-2737-1250	18565	6-1	3
MS35338-137	96906	6-6	39C	10-40450-14S	77820	6-6	7
MS35338-137	96906	6-6	40C	10-40450-18S	77820	6-6	6
MS35338-137	96906	6-8	16B	100-200-12A31	99378	6-8	21
MS35338-137	96906	6-8	17B	10509A1032-2	06540	6-6	25
MS35338-138	96906	6-6	25D	1200-074	12294	6-6	27

PART NUMBER	FSCM	FIG NO	ITEM NO	PART NUMBER	FSCM	FIG NO	ITEM NO
15D01800	82152	6-2	3	4035471-0701	06845	6-3	2
200092-01	16512	6-8	3	4035472-0701	06845	6-10	2
2074099-2301	06845	6-6	55	4035472-0702	06845	6-10	2A
2075056-0501	06845	6-6	45	4035472-0703	06845	6-10	2B
2075057-0701	06845	6-2	10	4035472-0704	06845	6-10	2C
2075058-0701	06845	6-2	11	4035474-0001	06845	6-8	2
2075059-0001	06845	6-4	8	4035480-0501	06845	6-9	13
2075059-0002	06845	6-5	7	4035482-0001	06845	6-8	5
2075059-0005	06845	6-2	6C	4035483-0001	06845	6-8	19
2075059-0006	06845	6-4	6	4035489-0501	06845	6-9	1
2075059-0007	06845	6-4	7	4035493-0001	06845	6-3	1A
2075059-0008	06845	6-5	8	4035493-0001	06845	6-9	11
2075059-0009	06845	6-5	6	4035494-0001	06845	6-9	2
2075059-0012	06845	6-7	4	4035495-0001	06845	6-6	3
2075059-0013	06845	6-7	4A	4035496-0501	06845	6-6	30
2075059-0014	06845	6-7	4B	4035503-0501	06845	6-8	18
2075073-0001	06845	6-9	10	4035504-0701	06845	6-6	36
2075079-0501	06845	6-6	10	4035505-0701	06845	6-6	37
2075079-0502	06845	6-6	42	4035507-0001	06845	6-2	2
2075079-0503	06845	6-6	43	4035522-0701	06845	6-3	3
22NKT40	72962	6-6	2D	4035523-0701	06845	6-3	4
2808BALBESP	91812	6-6	13	4035524-0701	06845	6-3	5
3-00005-114-1	06845	6-8	6	4035534-0701	06845	6-9	3
330	08806	6-6	19	4035535-0701	06845	6-9	4
3330-53-1	17117	6-6	54	4035536-0701	06845	6-9	5
4019391-0701	06845	6-6	16	4035544-0501	06845	6-3	1
4019510-0702	06845	6-2	12	4035546-0501	06845	6-3	7
4019513-0001	06845	6-6	32	4035547-0501	06845	6-3	6
4019514-0001	06845	6-6	33	4035549-0501	06845	6-2	8
4035450-0501	06845	6-8	1	4042881-0501	06845	6-6	3
4035451-0501	06845	6-1	1	4042882-0001	06845	6-6	5
4035452-0501	06845	6-1	2	4042883-0701	06845	6-6	4
4035453-0501	06845	6-2	4	4042888-0001	06845	6-6	38
4035454-0501	06845	6-2	5	4075C51	74868	6-2	9
4035455-0501	06845	6-2	6	50-028-0000	98291	6-7	2
4035456-0501	06845	6-2	1	58-007-0000	98291	6-2	6A
4035457-0501	06845	6-2	7	756	08806	6-6	24
4035458-0001	06845	6-6	34	7805KM	13715	6-8	14
4035459-0001	06845	6-8	29	7812KM	34148	6-8	13
4035460-0501	06845	6-6	35	9000-100-0037	72982	6-6	28
4035470-0501	06845	6-6	56	9950-6	95712	6-7	1

APPENDIX F

EXPENDABLE SUPPLIES AND MATERIALS LIST

Section I. INTRODUCTION

F-1. Scope

This appendix lists expendable supplies and materials you will need to operate and maintain the Transponder Set, Test Set AN/APM-378. These items are authorized to you by CTA 50-970, Expendable Items (Except Medical, Class V, Repair Parts, and Heraldic Items).

F-2. Explanation of Columns

a. Column 1—Item number. This number is assigned to the entry in the listing and is referenced in the narrative instructions to identify the material (e.g., “Use cleaning compound, item 5, App. D”).

b. Column 2—Level. This column identifies the lowest level of maintenance that requires the listed item.

C—Operator/Crew

O—Organizational Maintenance/Aviation
Unit Maintenance

F—Direct Support Maintenance/Aviation Intermediate Maintenance

H—General Support Maintenance

c. Column 3—National Stock Number. This is the National stock number assigned to the item; use it to request or requisition the item.

d. Column 4—Description. Indicates the Federal item name and, if required, a description to identify the item. The last line for each item indicates the Federal Supply Code for Manufacturer (FSCM) in parentheses followed by a part number.

e. Column 5—Unit of Measure (U/M). Indicates the measure used in performing the actual maintenance function. This measure is expressed by a two-character alphabetical abbreviation (e.g., ea, in, pr). If the unit of measure differs from the unit of issue, requisition the lowest unit of issue that will satisfy your requirements.

(Next printed page is F-2.)

SECTION II EXPENDABLE SUPPLIES AND MATERIALS LIST

(1) ITEM NO.	(2) LEVEL	(3) NATIONAL STOCK NUMBER	(4) DESCRIPTION PART NO. AND FSCM	(5) UNIT OF MEAS
3	0	850-00- 105-3085	TRICHLOROFLUOROETHANE	6 OZ.

By Order of the Secretary of the Army:

Official:

J. C. PENNINGTON
Major General, United States Army
The Adjutant General

E. C. MEYER
General, United States Army
Chief of Staff

DISTRIBUTION :

ACTIVE ARMY, USAR, ARNG: To be distributed in accordance with DA Form 12-36A, Organizational Maintenance requirements for AN/APM-123.

FILL IN YOUR
UNIT'S ADDRESS

FOLD BACK

DEPARTMENT OF THE ARMY

OFFICIAL BUSINESS

Commander
US Army Communications and
Electronics Materiel Readiness Command
ATTN: DRSEL-ME-MQ
Fort Monmouth, New Jersey 07703

FOLD BACK

TEAR ALONG DOTTED LINE

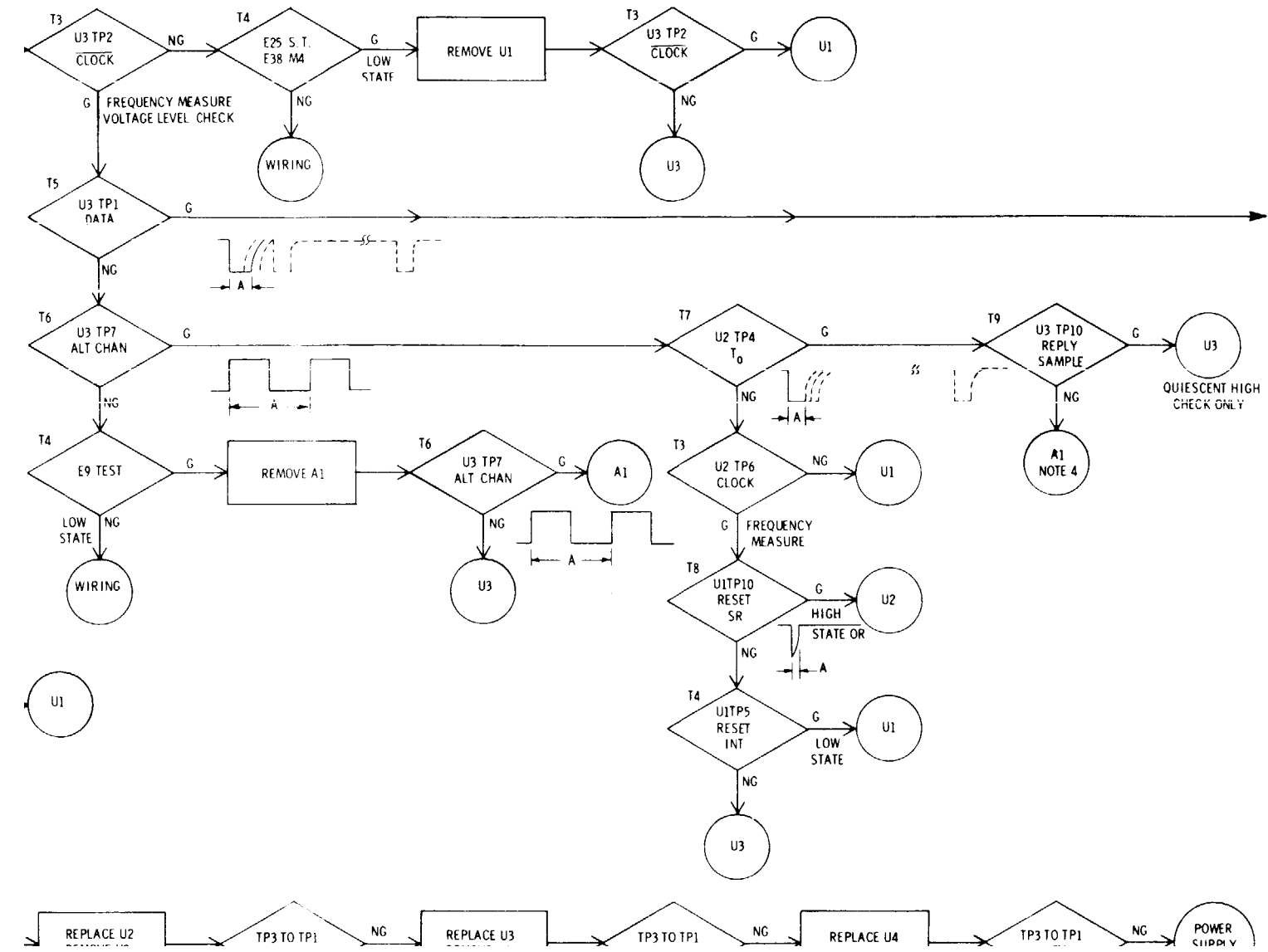
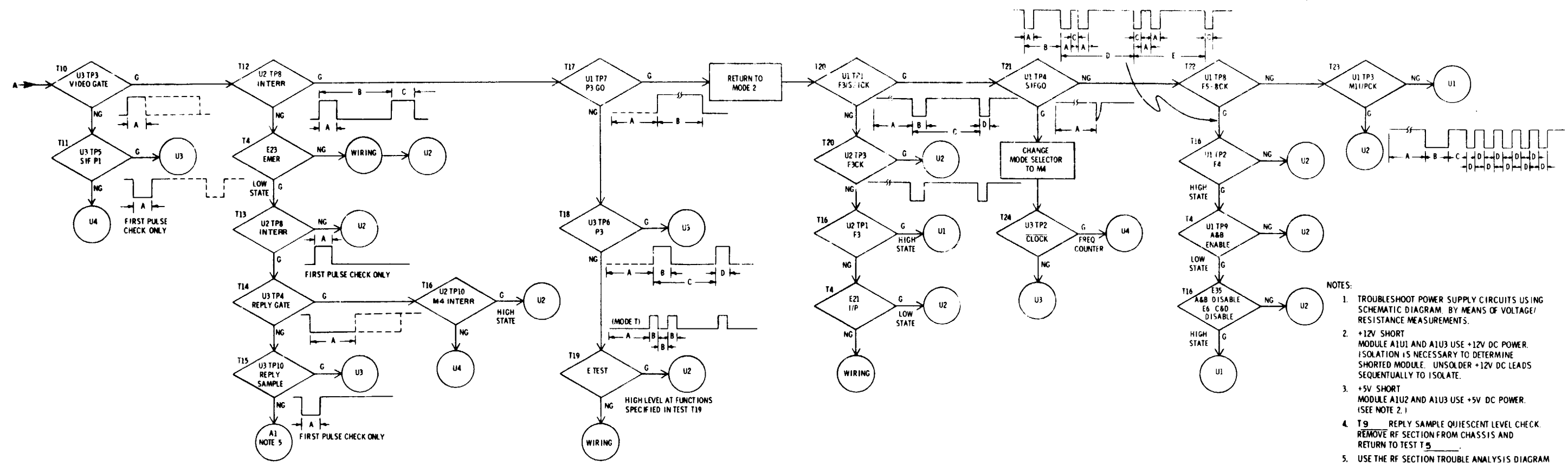

Figure 3-1. Test Set, General Trouble Analysis Diagram (Sheet 2 of 2)



089-008-026.2 A

- NOTES:
1. TROUBLESHOOT POWER SUPPLY CIRCUITS USING SCHEMATIC DIAGRAM. BY MEANS OF VOLTAGE/RESISTANCE MEASUREMENTS.
 2. +12V SHORT MODULE A1U1 AND A1U3 USE +12V DC POWER. ISOLATION IS NECESSARY TO DETERMINE SHORTED MODULE. UNSOLDER +12V DC LEADS SEQUENTIALLY TO ISOLATE.
 3. +5V SHORT MODULE A1U2 AND A1U3 USE +5V DC POWER. (SEE NOTE 2.)
 4. T9 REPLY SAMPLE QUIESCENT LEVEL CHECK. REMOVE RF SECTION FROM CHASSIS AND RETURN TO TEST T9.
 5. USE THE RF SECTION TROUBLE ANALYSIS DIAGRAM FOR A1 SUBASSEMBLY FAULT ISOLATION.
 6. IF ANY LAMP FAILS TO LIGHT DURING LAMP-TEST, REPLACE BURNED-OUT LAMP, CHECK LAMP WIRING, OR REPLACE MODULE U4 (WHICH CONTAINS LAMP DRIVER STAGES).

Figure 3-1. Test Set, General Trouble Analysis Diagram (Sheet 2 of 2)

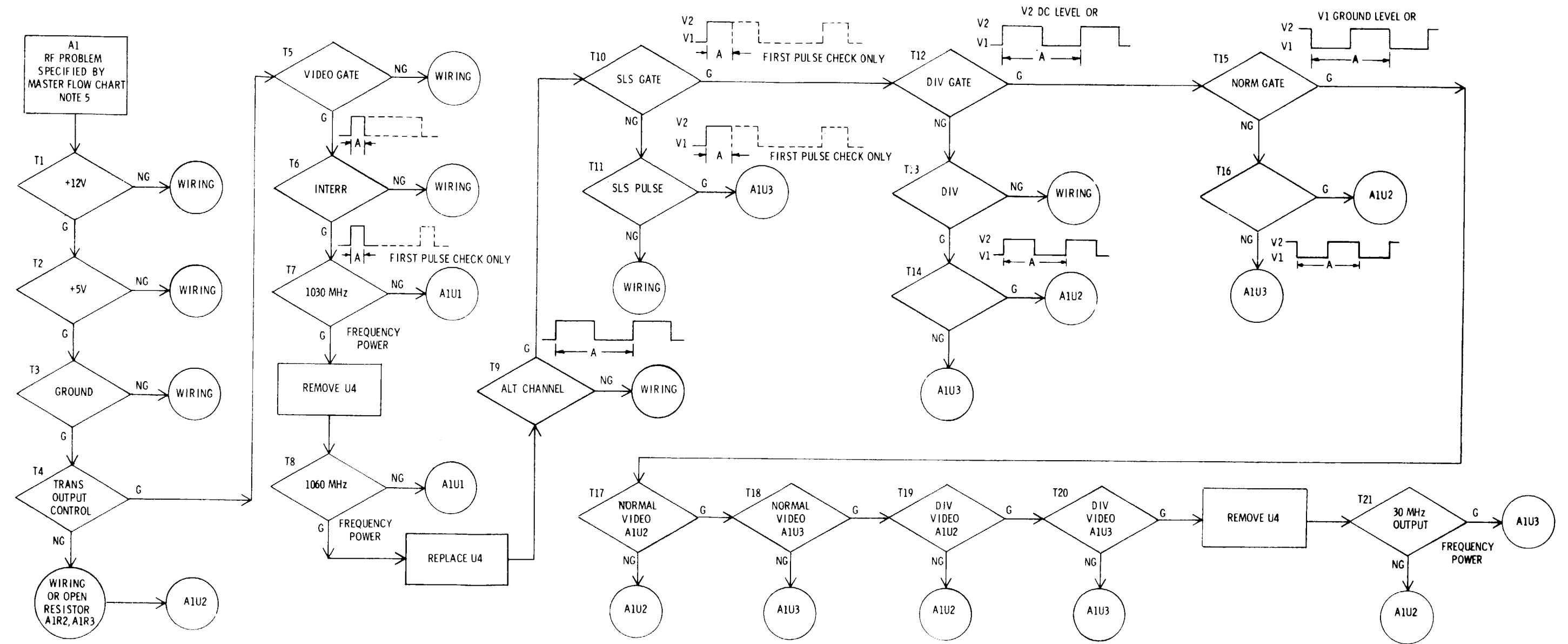

069-002-027 B

Figure 3-2. RF Section, Trouble Analysis Diagram

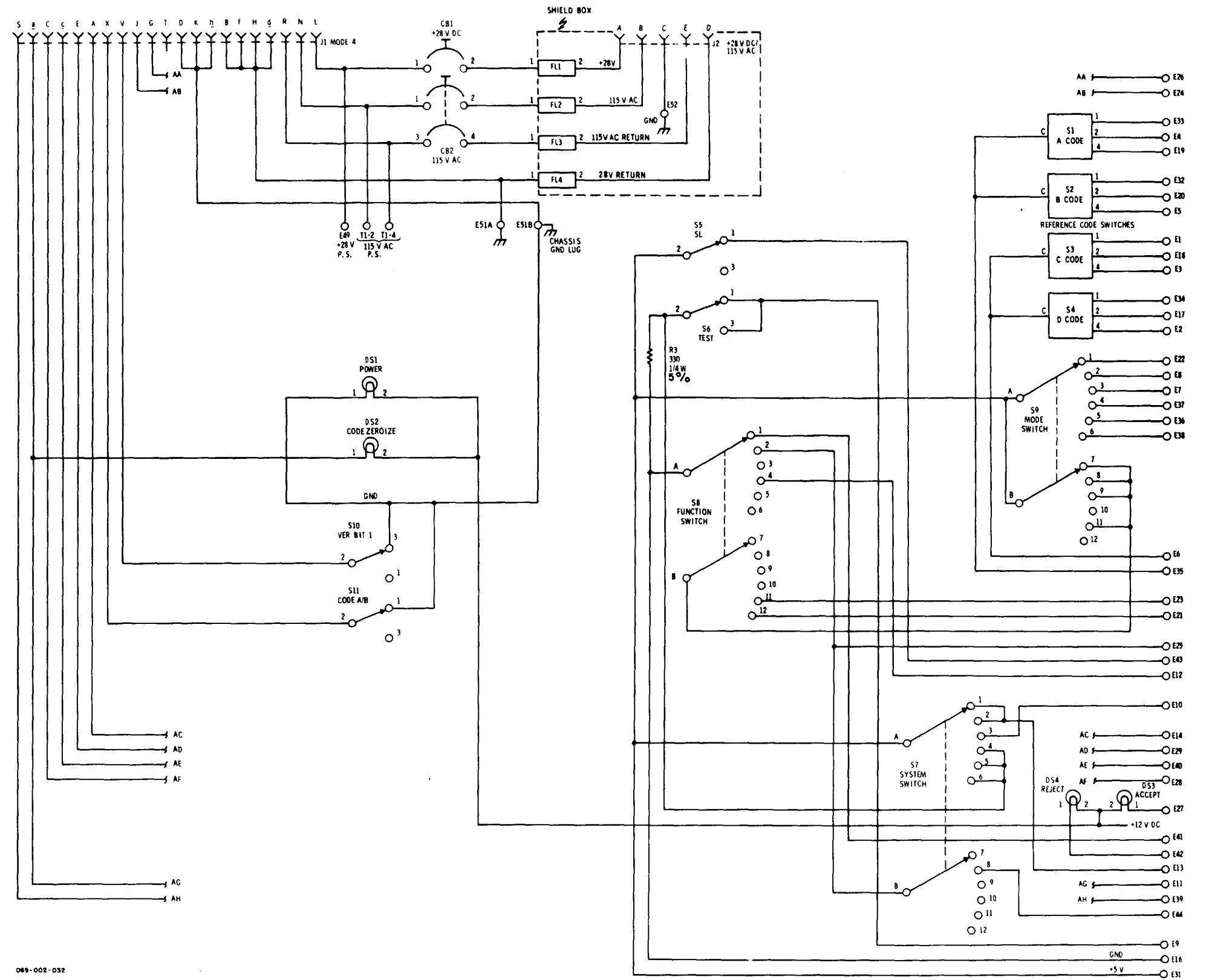

049-002-032

Figure 3-9. Transponder Set, Test Set AN/APM-378, Front Panel Schematic Diagram.

Change 1

